



Standard Guide for Selection, Design, and Installation of Dimension Stone Anchoring Systems¹

This standard is issued under the fixed designation C 1242; the number immediately following the designation indicates the year of original adoption or, in the case of revision, the year of last revision. A number in parentheses indicates the year of last reapproval. A superscript epsilon (ϵ) indicates an editorial change since the last revision or reapproval.

INTRODUCTION

Natural building stone is chosen as a building's cladding for its beauty which endures with minimal maintenance. Stone is durable when used properly. Exercising good judgment when selecting the particular stone, determining the quarrying and fabrication techniques, designing the method of attachment, and installing all components correctly maximizes these benefits. A properly executed stone cladding is designed and installed within the capabilities and limitations of the stone and support system to resist all forces that work on them.

This guide presents design principles that require consideration when designing anchorages and evaluating exterior stone to be compatible with its proposed use. It is an overview of current techniques and a review of minimum requirements for sound stone engineering and construction. The guide does not list all possible methods of attachment nor does it provide a step-by-step procedure for stone anchor engineering. Knowledge gained from new engineering designs, testing of applications, and the investigation of existing problems are continually reviewed to update this guide. Comment from users is encouraged.

Good judgment by architects, engineers, and contractors when specifying, designing, engineering, and constructing stone and other work that interfaces stone is necessary to use this guide. Users of this guide should combine known performance characteristics of the stone, the building's structural behavior, and knowledge of materials and construction methods with proven engineering practice.

1. Scope

1.1 This guide covers the categories of anchors and anchoring systems and discusses the design principles to be considered in selecting anchors or systems that will resist gravity loads and applied loads.

1.2 This guide sets forth basic requirements for the design of stone anchorage and provides a practical checklist of those design considerations.

1.3 This guide pertains to:

1.3.1 The anchoring of stone panels directly to the building structure for support,

1.3.2 The anchoring of stone panels to subframes or to curtainwall components after these support systems are attached to the building structure,

1.3.3 The anchoring of stone panels to subframes or to curtainwall components with stone cladding preassembled before these support systems are attached to the building structure, and

1.3.4 The supervision and inspection of fabrication and installation of the above.

1.4 Observe all applicable regulations, specific recommendations of the manufacturers, and standards governing interfacing work.

1.5 The values stated in inch-pound units are to be regarded as the standard. The SI units given in parentheses are for information only.

¹ This guide is under the jurisdiction of ASTM Committee C18 on Dimension Stone and is the direct responsibility of Subcommittee C18.06 on Anchorage Components and Systems.

Current edition approved April 1, 2004. Published May 2004. Originally approved in 1993. Last previous edition approved in 2003 as C 1242 – 03a.

1.6 This standard does not purport to address all of the safety concerns, if any, associated with its use. It is the responsibility of the user of this standard to establish appropriate safety and health practices and determine the applicability of regulatory limitations prior to use. (See Tables 1 and 2.)

2. Referenced Documents

2.1 ASTM Standards:²

- C 97 Test Methods for Absorption and Bulk Specific Gravity of Dimension Stone
- C 99 Test Method for Modulus of Rupture of Dimension Stone
- C 119 Terminology Relating to Dimension Stone
- C 170 Test Method for Compressive Strength of Dimension Stone
- C 406 Specification for Roofing Slate
- C 503 Specification for Marble Dimension Stone (Exterior)
- C 615 Specification for Granite Dimension Stone
- C 616 Specification for Quartz-Based Dimension Stone
- C 629 Specification for Slate Dimension Stone
- C 880 Test Method for Flexural Strength of Dimensional Stone
- C 1201 Test Method for Structural Performance of Exterior Dimension Stone Cladding Systems by Uniform Static Air Pressure Difference
- C 1354 Test Method for Strength of Individual Stone Anchorages in Dimension Stone
- C 1526 Specification for Serpentine Dimension Stone
- C 1527 Specification for Travertine Dimension Stone
- E 632 Practice for Developing Accelerated Tests to Aid Prediction of the Service Life of Building Components and Materials

3. Terminology

3.1 *General Definitions*—For definitions of terms used in this guide, refer to Terminology C 119.

² For referenced ASTM standards, visit the ASTM website, www.astm.org, or contact ASTM Customer Service at service@astm.org. For *Annual Book of ASTM Standards* volume information, refer to the standard's Document Summary page on the ASTM website.

TABLE 1 Dimension Stone Test Methods

Stone Type	ASTM Specification
Calcite ^A	C 503
Dolomite ^A	C 503
Granite	C 615
Limestone ^B	C 568
Marble (exterior) ^B	C 503
Quartz-Based ^B	C 616
Quartzite ^A	C 616
Quartzitic Sandstone ^A	C 616
Sandstone ^A	C 616
Serpentine ^A	C 503
Serpentine	C 1526
Slate (roof)	C 406
Slate (walls)	C 629
Travertine ^A	C 1527

^A This stone type is a subclassification.

^B This stone type has subclassifications or grades.

TABLE 2 Dimension Stone Test Methods

Measures	ASTM Test Method
liquid porosity and relative density	C 97
combined shear with tensile unit strength from bending	C 99
ultimate crushing unit strength	C 170
primary tensile unit strength from bending	C 880
capacity and deflections of panels assembled with their anchors onto their supporting backup structure	C 1201
individual anchor strength	C 1354
accelerated production of service life	E 632

3.2 Specific definitions used in the design process are listed in 8.4.

4. Significance and Use

4.1 This guide is intended to be used by architects, engineers, and contractors who either design or install exterior stone cladding for architectural structures.

4.2 This guide is an industry standard for engineering design considerations, documentation, material considerations, anchor type applications, and installation workmanship to assist designers and installers to achieve a proper and durable stone cladding.

4.3 Stone and its support systems are part of a building's skin and shall be compatible with the behavior and performance of other interfacing systems, such as the curtainwall and superstructure frame.

4.3.1 Every stone work application shall comply with applicable building codes.

4.3.2 It is not the intent of this Guide to supercede published recommendations for specific stone types. Provisions of other dimension stone industry publications should be reviewed and considered in addition to this Guide's recommendations. All industry information should be considered with respect to project specifications and requirements. If provisions of such publications differ from those in this Guide, it is acceptable practice to follow the publication's provisions if recommended by the stone specialist defined in 4.4 for the specific conditions of the individual project.

4.3.3 Because stone properties vary, the range and variability of pertinent properties of the stone proposed for use should be determined by testing and statistical methods that are evaluated using sound engineering principles. Use recent test data where applicable. Always reference proven performance of relevant existing structures.

4.3.4 Changes in properties over time shall be considered.

4.3.5 Overall behaviors of all building systems and components including the stone shall be interactively compatible.

4.4 *Stone Specialist*—Some conditions require professional expertise to select and plan a proper anchoring system, establish appropriate testing requirements, interpret tests, design and engineer the anchoring system, or monitor its fabrication and installation. A specialist is a person that complements the capabilities of the project team by contributing specific expert experience with the use, selection, design, and installation of dimension stone.

4.4.1 Particular conditions where special expertise is suggested to achieve a reliable installation:

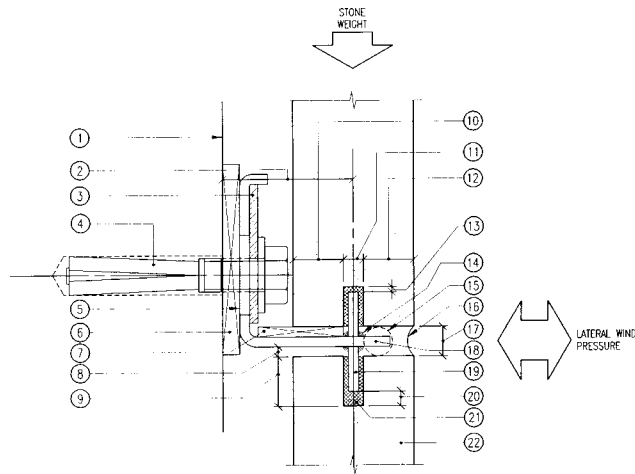

ANCHOR IN HORIZONTAL JOINT CAN SUPPORT GRAVITY AND LATERAL LOADS (FIGURE AS SECTION VIEW)
 ANCHOR IN VERTICAL JOINT CAN SUPPORT ONLY LATERAL LOADS (FIGURE AS PLAN VIEW)

- | | |
|--|---|
| <ul style="list-style-type: none"> ① SUPPORT ANCHORAGE ON COMPATIBLE, STABLE BACKUP. ② MINIMIZE DISTANCE TO MINIMIZE ECCENTRIC WEIGHT ON ANCHORAGE AND TO REDUCE FASTENER (PART 4) PULLOUT AND SUPPORT ANGLE (PART 17) DISPLACEMENT. ALLOW FOR FABRICATION, CONSTRUCTION AND INSTALLATION TOLERANCES. ③ PREVENT SLIP OF THE CONNECTION AFTER VERTICAL ADJUSTMENT WITH DIAGONALLY SLOTTED WASHER PLATE, WELD WASHER WITH WELD, OR SERRATED ANCHOR AND WASHER. DO NOT RELY ON FRICTION. ④ ATTACH ANCHOR WITH FASTENER TO BACKUP. ⑤ USE HORIZONTAL SLOT TO ALIGN DOWEL WITH HOLE. VERTICAL SLOT TO ALLOW FOR HEIGHT ADJUSTMENT AND FASTENER PLACEMENT. ⑥ PLACE PLASTIC OR METAL ADJUSTMENT BEARING SHIM SLIGHTLY LARGER THAN ANCHOR'S FASTENED FACE. REQUIRED TO SEPARATE AND ADJUST POSITION OF ANCHOR RELATIVE TO FRAMING. MINIMIZE THICKNESS TO MINIMIZE BENDING ON FASTENER (PART 4). THICKNESS AFFECTS FASTENER (PART 4) CAPACITY. ⑦ PLACE PLASTIC OR STIFF RUBBER BEARING SHIM FOR LEVELING, SEPARATION, AND TO PREVENT BEARING OF STONE ON DOWEL WELD. ADJUST ANCHOR VERTICALLY WITH PART 3, NOT SHIMS. ⑧ MAINTAIN CLEARANCE TO AVOID CONTACT AND WEIGHT TRANSFER (UNLESS DESIGNED TO STACK). ALLOW FOR MOVEMENT, CREEP, EXPANSION, AND FABRICATION, AND INSTALLATION TOLERANCES. ⑨ MINIMIZE HOLE DEPTH, INCLUDING VARIANCES PER PART 20, MAINTAIN 3/8 IN. (10mm) ENGAGEMENT OR TESTED MINIMUM. GREATER ENGAGEMENT DOES NOT NECESSARILY INCREASE ANCHOR CAPACITY. ⑩ VERIFY INTERIOR EDGE DISTANCE. STONE HERE RESISTS NEGATIVE (OUTWARD AND SUCTION) PRESSURE. MAINTAIN SUFFICIENT WIDTH FROM MINIMUM PANEL THICKNESS. ⑪ LOCATE HOLE IN CENTER THIRD OF PANEL THICKNESS. MINIMIZE DIAMETER TO MAXIMIZE EDGE DISTANCE (PARTS 10 AND 12). | <ul style="list-style-type: none"> ⑫ VERIFY EXTERIOR EDGE DISTANCE. STONE HERE RESISTS POSITIVE (INWARD) PRESSURE. KEEP THIS DIMENSION CONSTANT FROM OUTSIDE FACE TO KEEP PANEL FACES ALIGNED. ⑬ MAINTAIN CLEARANCE TO AVOID POINT LOADING ON DOWEL END. DIMENSION TO EQUAL OR EXCEED PART 7. ⑭ WELD AT FIXED DOWEL. MINIMUM DIAMETER HOLE ONLY FOR CLEARANCE AT DROP (LOOSE) DOWEL. ⑮ BOND BREAKER AT ANCHOR AND BACKER ROD BEYOND TO PREVENT THREE SIDED SEALANT BOND. ⑯ FILL JOINTS BETWEEN PANELS WITH COMPRESSIBLE GASKET OR SEALANT WITH PROPER PROFILE AND COMPATIBILITY. ⑰ SIZE JOINTS TO ALLOW FOR HARDWARE, TOLERANCES, CLEARANCES, APPROPRIATE MOVEMENT AND JOINT FILLER CAPABILITY. ISOLATE DYNAMIC BUILDING MOVEMENTS FROM THIS TYPE OF ANCHOR. ⑱ CONNECT DOWEL TO BACKUP WITH METAL LATERAL AND GRAVITY SUPPORT ANGLE (BRAKE-FORMED SHAPED SHOWN). CAN ALSO BE ROLLED OR EXTRUDED SHAPE. ⑲ ENGAGE PANEL EDGE WITH A FIXED OR DROP (LOOSE) METAL DOWEL. AVOID DOWEL MISALIGNMENT IN HOLE AND RESULTING PRYING ON STONE PANEL. ⑳ MAINTAIN CLEARANCE TO AVOID POINT LOADING ON DOWEL ENDS. DIMENSION TO EQUAL OR EXCEED PART 8. DO NOT ALLOW FLOOR-TO-FLOOR MOVEMENTS TO OCCUR IN THE HOLES. ㉑ FILL HOLES WITH COMPRESSIBLE MATERIAL TO PREVENT MOISTURE ACCUMULATION, TO FIX POSITION, AND TO CUSHION BEARING OF DOWEL ON SIDES OF HOLE. WAX, GREASE, WRAP TAPE ON DOWEL OR BED A SLEEVE FOR THE DOWEL TO SLIDE ON WHERE ADHESION IS NOT DESIRED. ㉒ DIMENSION STONE CLADDING FACE PANEL. |
|--|---|

FIG. 1 Dowel Anchor

4.4.1.1 Where complex connections or anchoring methods of unknown or questionable performance records are likely to be considered or specified;

4.4.1.2 Where the performance record of the specified systems and materials is not known or questionable;

4.4.1.3 When multiple cladding materials occur on the same facade;

4.4.1.4 If the supporting structure or backup is more flexible than L/600 in any direction;

4.4.1.5 If extreme loading could be caused by seismic, hurricane, tornado, or installation and handling methods;

4.4.1.6 When special building code requirements prevail.

4.4.1.7 If provisions of stone industry publications or project specifications differ from this guide.

5. Installation Standards

5.1 *Documentation*—The basis for standard workmanship shall be established in the design documents issued to describe, regulate, or control the construction. These documents may be

issued by the architect, engineer, the design-build authority, the contractor, or others authorized to impose law or code. Examples are as follows:

5.1.1 The architectural drawings and specifications identifying stone type, finish, thickness, sizes, and details and the relationship to other architectural elements and the building structure.

5.1.2 The architectural drawings and specifications identifying the scope of work and the materials required. These may: (1) define the performance criteria to be satisfied, (2) specify the standards of performance to be used in meeting those criteria, (3) provide for adequate performance guarantees for the materials and methods of construction, and (4) prescribe definitive material details and systems to satisfy project requirements. In addition, the specifications shall establish stone fabrication and installation tolerances. The tolerances recommended by stone trade associations could be used as a guide and included in the specification.

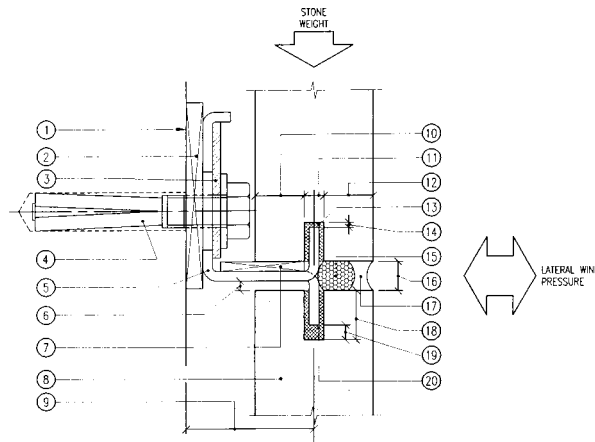

ANCHOR IN HORIZONTAL JOINT CAN SUPPORT GRAVITY AND LATERAL LOADS (FIGURE AS SECTION VIEW)
 ANCHOR IN VERTICAL JOINT CAN SUPPORT ONLY LATERAL LOADS (FIGURE AS PLAN VIEW)

- | | |
|--|---|
| <ul style="list-style-type: none"> ① SUPPORT ANCHORAGE ON COMPATIBLE, STABLE BACKUP. ② PLACE PLASTIC OR METAL ADJUSTMENT BEARING SHIM SLIGHTLY LARGER THAN ANCHOR'S FASTENED FACE. REQUIRED TO SEPARATE DISSIMILAR MATERIALS AND ADJUST TO FRAMING. MINIMIZE THICKNESS TO MINIMIZE BENDING ON FASTENER (PART 4). ③ PREVENT SLIP OF THE CONNECTION AFTER VERTICAL ADJUSTMENT WITH DIAGONALLY SLOTTED WASHER PLATE, WELD WASHER WITH WELD, OR SERRATED ANCHOR AND WASHER. DO NOT RELY ON FRICTION. ④ ATTACH ANCHOR WITH FASTENER TO BACKUP. ⑤ KERF ANCHOR (BRAKE-FORMED SPLIT-EAR SHAPE SHOWN) OR EXTRUDED SHAPE THAT FITS INTO SAWN KERF. AVOID MISALIGNMENT AND RESULTING PRYING ON KERF FROM INACCURATE FABRICATION OR INSTALLATION. SHOULD NOT BE CONTINUOUS ACROSS PANEL JOINTS. CAPACITY OF CONNECTION IS NOT DIRECTLY PROPORTIONAL TO ANCHOR LENGTH. ⑥ MAINTAIN CLEARANCE TO AVOID CONTACT AND WEIGHT TRANSFER (UNLESS DESIGNED TO STACK). ALLOW FOR MOVEMENT, CREEP, EXPANSION, AND FABRICATION AND INSTALLATION TOLERANCES. ⑦ PLACE PLASTIC OR STIFF RUBBER BEARING SHIM FOR LEVELING, SEPARATION, AND TO PREVENT BEARING OF STONE KERF FIN ON ANCHOR RADIUS. ADJUST ANCHOR VERTICALLY WITH PART 3, NOT SHIMS. ⑧ DIMENSION STONE CLADDING FACE PANEL. ⑨ MINIMIZE DISTANCE TO MINIMIZE ECCENTRIC WEIGHT ON ANCHOR - REDUCES FASTENER (PART 4) PULLOUT AND SUPPORT ANCHOR (PART 5) DISPLACEMENT. ⑩ VERIFY INTERIOR KERF FIN. STONE HERE RESISTS NEGATIVE (OUTWARD OR SUCTION) PRESSURE. MAINTAIN SUFFICIENT WIDTH FROM MINIMUM PANEL THICKNESS. | <ul style="list-style-type: none"> ⑪ LOCATE CONTINUOUS OR INTERMITTENT SAWCUT KERF IN CENTER THIRD OF THICKNESS. CONTROL WIDTH TO ALLOW TOLERANCE WITH KERF ANCHOR. MINIMIZE WIDTH TO MAXIMIZE EDGE DISTANCES (PARTS 10 AND 12). ⑫ VERIFY EXTERIOR KERF FIN (3/8 IN. (10mm) MINIMUM) STONE HERE RESISTS POSITIVE (INWARD) PRESSURE. KEEP THIS DIMENSION CONSTANT TO KEEP STONE FACES ALIGNED. ⑬ FILL KERF IN BOTTOM EDGE OF STONE ONLY AT ANCHORS WITH SEALANT TO SET POSITION AND TO CUSHION BEARING. ⑭ MAINTAIN CLEARANCE TO AVOID POINT LOADING AT TOP AND BOTTOM. DIMENSION TO EQUAL OR EXCEED PART 6. DO NOT ALLOW FLOOR-TO-FLOOR MOVEMENTS TO OCCUR IN THE KERF. ⑮ PLACE BACKER ROD OR FOAM TAPE AT PROPER DEPTH TO PREVENT THREE-SIDED SEALANT BOND. ⑯ SIZE JOINTS TO ALLOW FOR HARDWARE, TOLERANCES, CLEARANCES, APPROPRIATE MOVEMENT, AND JOINT FILLER CAPABILITY. ISOLATE DYNAMIC BUILDING MOVEMENTS FROM THIS TYPE OF ANCHOR. ⑰ FILL JOINTS BETWEEN PANELS WITH COMPRESSIBLE GASKET OR SEALANT WITH PROPER PROFILE AND COMPATIBILITY. ⑱ MINIMIZE KERF DEPTH TO MINIMIZE PRYING AND MAXIMIZE CAPACITY. MAINTAIN 3/8 IN. (10mm) MINIMUM OR TESTED MINIMUM ENGAGEMENT. ⑲ MAINTAIN CLEARANCE TO AVOID POINT LOADING AT KERF IN TOP OF STONE. DIMENSION TO EQUAL OR EXCEED PART 6. DO NOT ALLOW DYNAMIC DISPLACEMENTS TO OCCUR IN THE KERF. ⑳ FILL KERF IN TOP EDGE OF STONE CONTINUOUSLY WITH SEALANT TO TOP OF KERF TO PREVENT MOISTURE ACCUMULATION. SET POSITION, AND CUSHION BEARING OF ANCHOR ON SIDES OF KERF. |
|--|---|

FIG. 2 Kerf Anchor

5.1.3 Project specifications shall cite the ASTM standard material specification (see 2.1) governing the stone intended for use and identify the classification or grade within that standard specification.

5.1.4 Shop drawings indicating in detail all parts of the work required, including material types, thicknesses, finishes and all other pertinent information dealing with fabrication, anchorage, and installation. The drawings shall show contiguous materials or assemblies which are provided by others in their range of positions according to their specified tolerances.

5.2 *Tolerances*—Installation tolerances and requirements, once specified, bind the installation contractor, by contract, to perform the work within those specified tolerances. The specification requires the installation contractor to progressively examine the construction to which his work attaches or adjoins, reporting to the prime contractor any condition that may prevent performance within the standard established. Some commonly specified installation tolerances follow:

5.2.1 Variation from plumb of wall surfaces, arises, external corners, joints, and other conspicuous lines should not exceed 1/4 in. (6.4 mm) in any story or in 20 ft (6.1 m) maximum.

5.2.2 Variation in level from grades shown for horizontal joints and other conspicuous lines should not exceed 1/4 in. in 20 ft (6.4 mm in 6.1 m) maximum, nor 3/4 in. in 40 ft (19.1 mm in 12.2 m) or more.

5.2.3 Variation in linear building lines from positions shown on drawings and related portion of wall facing should not exceed 1/2 in. (12.7 mm) in any bay or 20 ft (6.1 m) maximum, nor 3/4 in. in 40 ft (19.1 mm in 12.2 m) or more.

5.2.4 Variation in the face plane of adjacent pieces (lippage) should not exceed one fourth of the width of the joint between the pieces up to but not more than 1/16 in. (1.5 mm) unless panel finish is not smooth or panel size exceeds 20 ft²(1.8 mm²).

5.3 *Workmanship*—Good construction requires mechanics that have previous successful experience installing similar stonework to do the new work. Less experienced personnel can

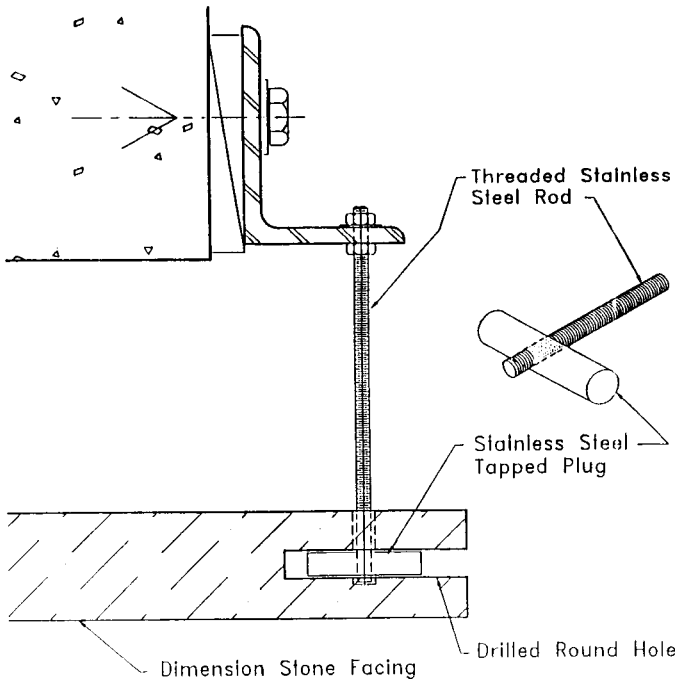

FIG. 3 Rod and Plug Anchor

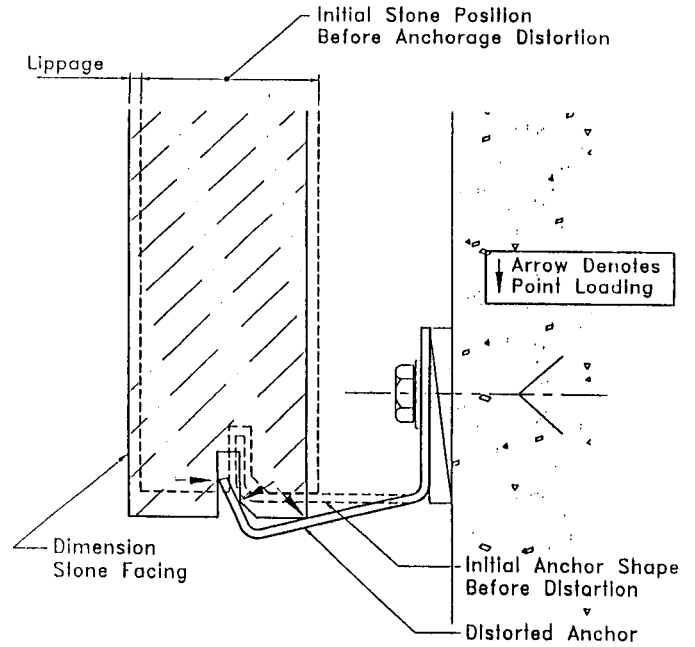

FIG. 5 Point Loading Prevention

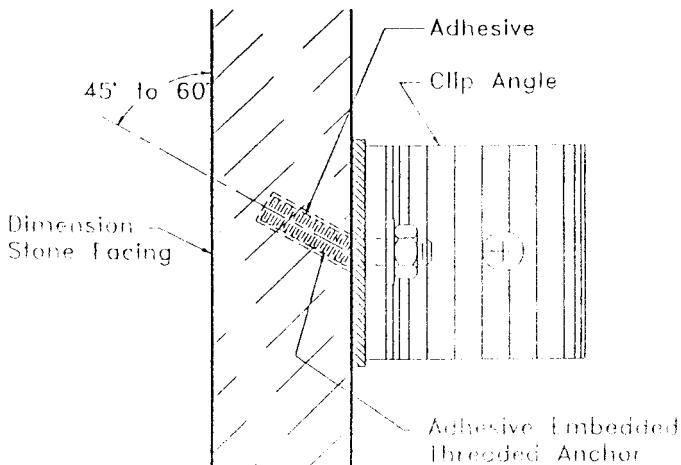

FIG. 4 Adhesive Embedded Threaded Anchor

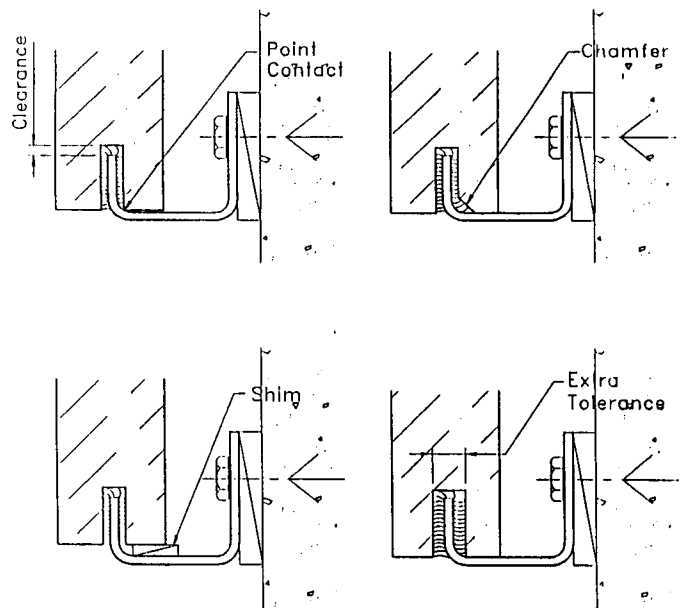

FIG. 5 Point Loading Prevention (continued) (continued)

only be allowed when they work in a crew continuously with the mechanic who has previous successful experience. Similar work means same type of site fabrication, anchorage, setting method, and support system as the new work.

6. Materials of Construction

6.1 Metals:

6.1.1 Metals used for anchors or anchorage system components are selected according to their use:

6.1.1.1 Metal in contact with stone should be AISI Type 302, 304 or 316 stainless steel, or bronze, or aluminum coated with epoxy paint or equivalent coating. Mill finish or anodized aluminum can be used with granite. Use Type 316 stainless steel when project is located in a coastal or other corrosive environment. Avoid Type 302 in environments exposed to chlorine. Avoid Type 304 in environments exposed to chloride. Copper, brass and stainless steel wire are used for ties.

6.1.1.2 Exterior wire ties used with cement mortar spots should be ductile stainless steel. Avoid copper and aluminum with mortar due to incompatibility. Stainless steel, copper, brass and aluminum can be used with gypsum or molding plaster for interior applications. Verify mortar or plaster will not darken or stain stone before using wire ties with spots for anchors.

6.1.1.3 Metal not in direct contact with stone exposed to weather should be stainless steel, galvanized steel, zinc-rich painted or epoxy-coated steel, or aluminum.

6.2 Joint Sealants:

6.2.1 Sealants used in contact with stone can be of the type recommended for the application by the manufacturer, but

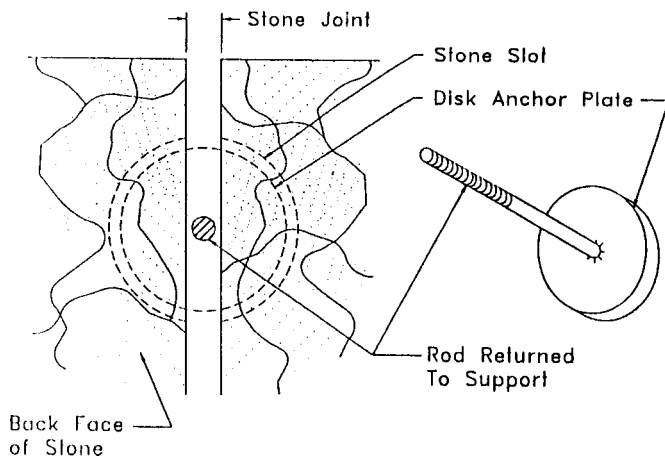

FIG. 6 Disc Anchor

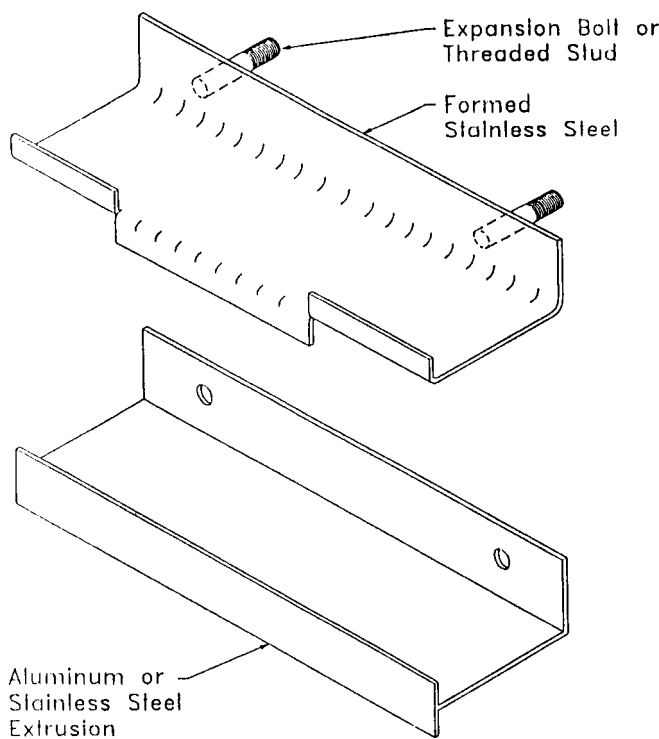

FIG. 7 Combined Anchor

proper consideration should be given to their ability to satisfy the required properties of tear and peel strength, elasticity, compressibility, durometer, resistance to soiling and fading, and compatibility with any other sealant with which it may come in contact.

6.2.1.1 The manufacturer's recommendation should be followed in respect to temperature range of application, the condition of the substrate and the necessity for a primer.

6.2.1.2 Some sealants may bleed into stone; proper testing is recommended.

6.3 Mortar Materials:

6.3.1 Portland cement, masonry cement, and lime used in preparing cement and lime mortar should be non-staining.

6.3.2 Non-shrink grout should not be used.

6.4 Gasket Materials:

6.4.1 Gasket material selection should be made to satisfy the movement and tolerance requirements. Gaskets are available in a variety of sections: tubular, lobed, and cellular being the most common. Some gasket materials may bleed into some stones and cause staining. The recommendation of the manufacturer should be followed. Testing may be prudent where information from the manufacturer is not sufficient assurance that bleeding will not occur.

6.4.1.1 Extruded gaskets are usually neoprene or vinyl.

6.4.1.2 Cellular gaskets are usually foamed butyl, polyethylene, or polyurethane.

7. Selection Considerations

7.1 Review the following factors before selecting a stone material, an anchoring system and subframe system from those options being considered:

7.1.1 Have the stone materials under consideration performed well on existing buildings in similar exposures?

7.1.2 Have the different anchoring and subframe systems under consideration performed well on existing buildings in similar exposures?

7.1.3 How is the performance of the anchor and its engagement into the stone affected by installation and handling procedures?

7.1.4 How are the performance and appearance of the subframe, the anchor's connection to the subframe, and the subframe's connections to the building structure affected by differential movements?

7.1.5 Do the physical characteristics of the stone measured by standard tests show the material has structural limitations? Which physical properties are important to the application, and which test methods measure those properties and their variability? Refer to Table 2 for standard test methods and properties they measure.

7.1.6 Do the physical characteristics of the stone not measured by standard tests suggest the material may have long-term durability concerns? Other properties, including (but not limited to) resistance to chemical attack, weather-related strength reduction, and dimensional changes, might be evaluated by special laboratory tests designed to obtain data under simulated conditions.

7.1.7 Does the project location or shape develop exceptional design wind, or seismic loads, or does the stone material require higher safety factors than other stones not anticipated by statutory codes?

7.1.8 Do the anchor and subframe system accommodate building dimensional changes caused by wind and seismic sway, thermal and elastic deformation, creep and shrinkage, and their combined effects?

7.1.9 Will contiguous facade elements such as windows, other claddings, window supports, or window-washing and wall maintenance provisions influence the stone cladding, its anchoring or subframe system?

7.1.10 Do the anchor or subframe systems penetrate waterproofing, facilitate internal moisture collection, or penetrate wall insulation and cavity ventilation?

7.1.11 Do the materials used resist corrosion, galvanic and chemical reactions?

7.2 The following general rules are helpful in the design of anchors and connections:

- 7.2.1 The simplest connections are usually the best.
- 7.2.2 Make connections with the fewest components.
- 7.2.3 Use the fewest possible anchor connection types in any particular project.
- 7.2.4 Provide for adjustability in connections to accommodate tolerances in materials and construction.
- 7.2.5 Distribute the weight of stone or panel systems on no more than two points of connection where possible.

7.2.6 Make anchor connection locations accessible to the craftsman.

7.2.7 Design connection components and stone sinkages to avoid entrapping moisture.

7.2.8 At friction connections with slotted holes parallel to the direction of load, specify proper bolts, washers, slot size, and bolt installation procedure.

7.3 *Safety Factors*—In order to design an anchoring system, the variabilities of the materials being considered should be known and compensated. This is accomplished through the use of an appropriate safety factor to be applied to the stone, the anchorage, and the backup structure.

7.3.1 Table 3 shows generally accepted Safety Factors for stone cladding by stone type. These factors are recognized by industry specialists and publications and are based upon past successful practice. These factors are based on a maximum coefficient of variation of 20 % when project samples are tested in accordance with Test Methods C 99 or C 880 for sedimentary stones in thicknesses of 2 in. (50 mm) or greater. Safety factors could be changed when conditions listed under 7.3.2 or 7.3.3 exist in the project.

7.3.2 *Exemplar Availability:*

A safety factor could be modified if the long-term performance of the stone material, anchor and backup system cannot be verified by well-performing exemplars. Consult a stone specialist as defined in 4.4 for the appropriate change in safety factor.

7.3.3 *Structural Variables:*

A safety factor could be modified if specific conditions exist on the project different from those upon which Table 3 values are based. Consult a stone specialist as defined in 4.4 for the appropriate change in safety factor. Some specific conditions are:

- 7.3.3.1 Critical material strength tests show increased variability;
- 7.3.3.2 Life expectancy of project exceeds forty years;
- 7.3.3.3 Stone material loses significant strength over time;
- 7.3.3.4 When designing stone at anchors;
- 7.3.3.5 Anchor capacity tests show increased variability;

7.3.3.6 Anchors will not be inspected in final position on building;

7.3.3.7 Anchors require varied installation techniques or varied positions;

7.3.3.8 Panel is used in higher-risk position such as a soffit, overhang, liner block, assembled on backup before being erected or other similar position.

8. Design Process

8.1 *System Parts*—There are five main interrelated parts in a stone facade system that are to be considered when designing the cladding system:

- 8.1.1 *Stone Panels*, cladding the facade,
- 8.1.2 *Joints*, between the panels,
- 8.1.3 *Anchor*, connecting the cladding to the supporting backup,
- 8.1.4 *Subframes*, connecting the anchors to the building structure where the anchor does not attach directly to the building, and
- 8.1.5 *Primary Building Structure*.

8.2 *Process Purpose*—In this section a recommended process is provided to help designers select and design anchors that provide a reliable and durable overall cladding system. The process begins with preliminary design by evaluating exemplars, then confirms the system’s fitness with engineering by structural analysis and appropriate physical tests. Engineering first evaluates individual parts of the system, then evaluates key assemblies of parts, then evaluates the fully built system.

8.3 *Process Scope*—This section outlines primary elements that should be considered in the design process. Extent of exemplar assessments, analyses and tests needed to formulate a well-performing preliminary design and establish its reliability and durability varies with the type of project, its size, location, and applicability of exemplars. Consider employing a specialist experienced with stone materials, anchors, backup and building structure to develop an assessment, analysis and testing program appropriate for the project if additional expertise is needed. All listed elements are not required for all projects. Some projects may require elements not listed.

8.3.1 Proposed cladding systems which have stone materials in thickness modules, panel sizes, anchors, and backups very similar to well-performing exemplars in the same climate may, at the architect’s option, be exempted from some or all of the testing program if analysis assures the system is reliable and durable.

8.3.2 Proposed cladding systems that do not have sufficiently-old well-performing exemplars sharing similar stone materials in thickness modules, panel sizes, anchors and backups and in the same climate probably require testing and analysis during preliminary design. At the architect’s option, systems without exemplars require an extensive testing program and analysis to attempt to predict system reliability and durability in the proposed application and its climate.

8.3.3 Projects to be built very similar to well-performing exemplars require less rigorous analysis and testing.

8.3.4 Projects to be built of less-commonly-used materials or common materials in unconventional systems lacking precedents of well-performing exemplars require more rigorous analysis and testing.

TABLE 3 Generally Accepted Safety Factors for Stone Cladding by Stone Type

Stone Type	Specification	Safety Factor
granite	C 615	3
limestone	C 568	6
group A marble	C 503	5
travertine	C 1527	8
sandstone	C 616	6
slate	C 629	5

8.3.5 Assess exemplars to develop cladding system concept and complete preliminary engineering and testing before determining if the desired stone or the proposed cladding backup is appropriate. Do not choose a stone material for its appearance without verifying it is appropriate for the project climate. Also, do not choose a backup system without matching it to the project climate, stone anchor requirements and architectural arrangement of cladding.

8.4 Terminology:

8.4.1 *exemplar, adj*—a constructed example sharing some similar parts, assemblies, arrangements or exposures with the proposed system.

8.4.1.1 *well-performing, adj*—the example is serviceable its entire expected life. Serviceable stone cladding systems maintain their original integrity without more than routine upkeep. How long an example should be serviceable will vary by building type, owner, user, builder or designer, but the longer it remains serviceable, the more reliable and durable it is. A well-performing exemplar is only as reliable and durable to the extent its cladding system performs as expected over time.

8.4.1.2 *poor-performing, adj*—stone-cladding system integrity declines unexpectedly before it should. While observable deficiencies may show some parts of an example to be poor-performing, absence of seen problems without confirming performance by inspecting concealed conditions or testing does not necessarily make it a well-performing example.

8.4.2 *durable, adj*—the building system performs reliably during its entire service life and will endure environmental exposure and changes in adjacent elements without diminished serviceability. Make the design durable by assessing exemplars and including their well-performing elements while avoiding their poorly-performing elements.

8.4.3 *reliable, adj*—the building system performs while remaining in a safe state under load cases outlined by code or greater loads if required by the project. Establish reliability using an engineering evaluation that shows how well loads on cladding are carried through the panel, anchors and backup support system to the building structure.

8.5 *Preliminary Design*—Assess exemplars to extract concepts critical to developing preliminary designs with high reliability and durability. Assess both well-performing and poor-performing exemplars. The highest reliability and durability can be attained when the preliminary design includes elements of well-performing exemplars and excludes elements of poor-performing exemplars. General exemplar assessment should include the following:

8.5.1 Buildings using the same stone material being considered in the architectural concept, in an environment similar to the new project's location.

8.5.1.1 Check stone panel sizes, thickness, support points where possible. Research whether current quarry operations yield similar product and if tests of recently fabricated material are consistent with past production ten, twenty or fifty years ago. This check will help keep the architectural concept compatible with the structural properties of available stone materials and suggest the extent of new testing necessary.

8.5.1.2 Determine the realistic fabrication limitations of the stone by examining joint widths, piece sizes, piece shape,

material quantity, visual range and consistency of color, veining, and markings, type of finish, cleanliness in its location of use on the building. Research by visiting the quarry, or fabricator, or both, when possible or practical whether current fabrication capabilities and currently quarried deposits represent stone material observed an exemplar.

8.5.1.3 Learn properties of currently produced stone by visiting the quarry, or fabricator, or both, when possible or practical, and by obtaining previous test reports or a written statement from the producer to compare it to stone material observed on exemplar.

8.5.2 Buildings supporting cladding with similar anchors or backup being considered for the new project, independent of stone type. Obtaining this information likely requires contacting potential anchor manufacturers and stone installers to locate exemplars and once exemplars are identified, perhaps contacting their structural engineer or architect. An experienced cladding specialist could help decipher this information without excavating the wall. Marrying the appropriate support with the desired material is as critical to attaining a durable project as choosing the appropriate stone type.

8.5.2.1 Inspect the facade surface as closely as possible for symptoms of internal distress such as staining, cracks, spalls, open joints, shifted panels. Using binoculars and hands-on where possible, check arrises, sills, copings, building corners, plane changes, and where cladding meets windows, curtainwall and roof at conditions similar to the proposed project.

8.5.2.2 Inspect the facade as closely as possible for signs of difficult fit, such as lippage, warped planes, uneven corners and tapering joints. Try to learn if building structure, backup, stone fabrication, or setting caused the problems.

8.5.3 Examine buildings that feature similar architectural elements or arrangements being considered, independent of stone, anchor, or backup type.

8.5.4 *Minimum Panel Thickness*, can vary with stone type, panel size, panel location and orientation on the building, exposure and expected service life, anchor type and arrangement, handling or shipping concerns, and architectural features like finishes and reveals. 8.5.4.1 recommends minimum nominal panel thicknesses of common stone types in typical conditions. Consider changing recommended thicknesses when conditions presented by 8.5.4.2-8.5.4.7 occur on the project.

8.5.4.1 *Stone Type*—Recommended minimum nominal thicknesses of exterior vertical, flat, smooth-finished panels that duplicate well-performing exemplars are: 30 mm (1 ¼ in) for granite, slate, high density limestone, group A marble and travertine; 50 mm (3 in) for course grained quartz-based stone and low-density limestone.

8.5.4.2 *Size and Location on Building*—Thicknesses shown in 8.5.4.1 could reduce if panels are smaller than approximately ¾ m² (8 ft²), or could increase if larger than 1 ½ m² (16 ft²) or occur in high wind pressures.

8.5.4.3 *Orientation and Exposure on the Building*—With considerations in 8.5.4.2-8.5.4.7, thickness could increase if panel experiences greater weather exposure than 8.5.4.2's typical panel or it is a coping, soffit, cornice, sill, overhang or liner block.

8.5.4.4 *Expected Service Life: With Considerations*—With considerations 8.5.4.2-8.5.4.7, thickness could increase if facility is expected to remain in service longer than its exemplar.

8.5.4.5 *Anchor Arrangement and How It Engages The Panel*—With considerations 8.5.4.2-8.5.4.7, thickness could increase if support and arrangement of anchors in combination with panel size cannot be refined to reduce stresses below allowable. Slots, notches, rebates, holes, or other hidden-face fabrications required for the anchor to engage and connect to the stone affect overall panel thickness. Comply with 7.3 principles to arrange anchors.

8.5.4.6 *Handling or Shipping Concerns*—With considerations 8.5.4.2-8.5.4.7, thickness could increase if the fabricators specific review of project conditions or industry's published standards recommend so to address handling, shipping or other fabrication concerns.

8.5.4.7 *Architectural Features*—With considerations 8.5.4.2-8.5.4.6, thickness could increase if exposed face finish or finishing process, reveals or false joints reduce the effective structural capacity or potential durability of the panel.

8.6 *Engineering and Testing*—Use conventional structural engineering analysis methods with appropriate physical testing of system samples to predict the structural capacity of the stone cladding system. The engineering and testing program should include the following:

8.6.1 Tests of samples from Table 2 to confirm stone material properties exceed minimums required by design. Only test for properties important to how the stone will be used. New tests may be required if:

8.6.1.1 Existing data is more than two-years old, or

8.6.1.2 Existing data is not from area of quarry where project stone will be extracted, or

8.6.1.3 Project is large enough to justify project-specific tests or more specimens, or

8.6.1.4 Stone subjected to conditions different from conditions covered by existing test, or

8.6.1.5 Material properties are too variable to depend upon available data, or

8.6.1.6 Use of stone in system causes particular properties shown by structural analysis to approach maximum allowable design stresses. Test those properties;

8.6.1.7 If the desired stone has no exemplars in the project's climate.

8.6.2 Structurally analyze stone panel and compare test data to allowable design stresses (ultimate strength from tests reduced by safety factor appropriate for material and application).

8.6.3 Test actual anchor engaged into sample of project stone using Test Method C 1354 or structurally analyze stone and anchor device to confirm anchor strength exceeds minimum required by design. Modify test procedure if required to match project conditions according to 8.5.2. Isolating the anchor-to-stone condition may be necessary to verify anchor safety factors, which are higher for this part of the system than other system parts. New tests may be required if:

8.6.3.1 Structural calculations cannot conclusively model anchor behavior, or

8.6.3.2 Loads on anchor approach maximum allowed according to calculations not based upon tests, or

8.6.3.3 Anchors resist both lateral and gravity loads, or

8.6.3.4 Continuous edge anchors are less stiff than stone and thus may not provide effective support its full length, or

8.6.3.5 Anchor position in stone varies due to tolerances, or movement, or both, in facade system, or

8.6.3.6 *Modifications to Standard Test Methods*—Modify anchor test procedure to duplicate project conditions when:

(a) An anchor supports gravity and lateral loads. Preload anchor in test fixture with design gravity load times its factor of safety in the direction the load acts before adding lateral load;

(b) An anchor accepts differential floor-to-floor movement or bridges an expansion joint in backup. Set anchor in test fixture at extreme engaged and disengaged positions to determine condition causing minimum capacity.

(c) An anchor resists lateral loads in reversing directions. Apply loads in both directions at one times design load in that direction, repeat at two times design load, then three times, and continued until factor of safety is reached in both directions. Find fracture capacity by loading in the direction that pulls the panel off the building until failure.

8.6.4 Test full-size panel-and-anchor assembly using Test Method C 1201 to confirm system strength exceeds minimum required by design. Testing the assembled system may be necessary to verify behavior of the panel and assure parts work together properly. Also, isolating full-size panel from backup may be necessary to verify system factor of safety, which is higher for the panel-and-anchor assembly than the remaining facade system. Tests may be required if:

8.6.4.1 Panel is large and acts in two-way bending, or

8.6.4.2 Continuous edge anchor is not effective across entire panel length per 8.6.3.4.

8.6.5 Where the backup is not the primary building structure engineered by others, structurally analyze backup to confirm movement and deflections can be accommodated where anchors engage stone. Confirm backup's connections to building can adjust to fit tolerances of structure without being altered. Detail structural design to not compromise integrity of thermal, moisture, and vapor retarder envelopes.

8.6.6 Use Test Method C 99 or C 880 specimens fabricated from low-stressed regions of Test Methods C 1354 and C 1201 specimens and compare them to initial Test Methods C 99 or C 880 data to correlate results of the different strength test results. Consider difference, variability and behavior when finalizing anchor and system strength.

8.6.7 Test for durability when well-performing exemplars of sufficient age are not available by tailoring a project-specific procedure that follows Practice E 632. Test should evaluate all the following elements that occur in the project climate:

8.6.7.1 Freeze-thaw cycling,

8.6.7.2 Extreme temperature cycling with or without moisture,

8.6.7.3 Resistance to chemical pollutants,

8.6.7.4 Resistance to chemical reaction from adjacent building components,

8.6.7.5 Strength reduction and warping tendency when exposed to above weathering forces, or a combination thereof.

8.6.8 Use Test Method C 99 or C 880 specimens fabricated from stock produced for the project at appropriate intervals to confirm stone material strength remains relatively consistent and exceeds minimum required by design for the entire project. Test these specimens immediately during production to minimize potential delivery of understrength stone to project. Conditions in which this type of production testing may be required include:

- 8.6.8.1 Project uses large quantities of stone, or
- 8.6.8.2 Stone material variability, or design, or both, suggest strength must be monitored and maintained, or
- 8.6.8.3 Geologic deposit, or quarry conditions, or both, may not assure material consistent with the initial tests will be provided for the entire project, or
- 8.6.8.4 Loads approach maximums allowed.

9. Anchor Types

9.1 Anchor for Attaching Stone to Precast Concrete:

9.1.1 Dowel-type cladding anchors are generally smooth or threaded 300 (usually Type 302 or 304) series stainless steel rods inserted into holes in the back of the stone cladding.

9.1.1.1 The number of dowels is determined by analysis and testing.

9.1.1.2 The dowels anchor the cladding to the concrete backup. The angle of the dowel to the stone is usually 45°, angled into the precast, with the patterns opposing each other within the same stone. The holes for the dowels should be jig-drilled with diamond core bits. (See Fig. 8.)

9.1.1.3 The dowel embedment in to the stone should be a minimum of two-thirds of the thickness of the stone. The

bottom of the dowel hole should not be closer than 3/8 in. (9.5 mm) to the face of the stone. The embedded section of the dowel into the precast concrete backup should not be less than 2 1/2 in. (64 mm).

9.1.1.4 All dowels should be within the limits of the concrete reinforcing cage when viewed in elevation.

9.1.1.5 The recommended minimum diameter of dowels is 3/16 in. (4.8 mm).

9.1.2 Spring-type anchors, often referred to as hairpin anchors, are preformed from 300 series stainless steel. The recommended minimum diameter is 5/32 in. (4.0 mm). Hairpin anchors are oriented perpendicular to the load. The number of anchors is determined by analysis and testing.

9.1.2.1 The anchor embedment into the back of the stone is usually 3/4 in. (19.1 mm) deep. Two opposing holes are drilled into the back of the stone at an angle of 45° to the plane of the back. These holes are either angled toward or away from each other, depending upon the configuration of the hairpin anchor. The straight legs of the anchor are inserted into the holes, the shape of the anchor acting to keep the legs engaged. The recommended minimum distance between the bottom of the anchor hole and the finished face of the stone is 3/8 in. (9.5 mm). (See Fig. 8.)

9.1.3 Precast cladding anchors, whether dowel or hairpin type, have certain shear and tensile (pull out) values for each stone variety and concrete type and strength. These values are determined from tests of the actual concrete and cladding stone being considered.

9.1.3.1 No strength value is assigned or considered between the cladding stone and the concrete backup. A bond breaker should be provided between the stone cladding and the precast backup.

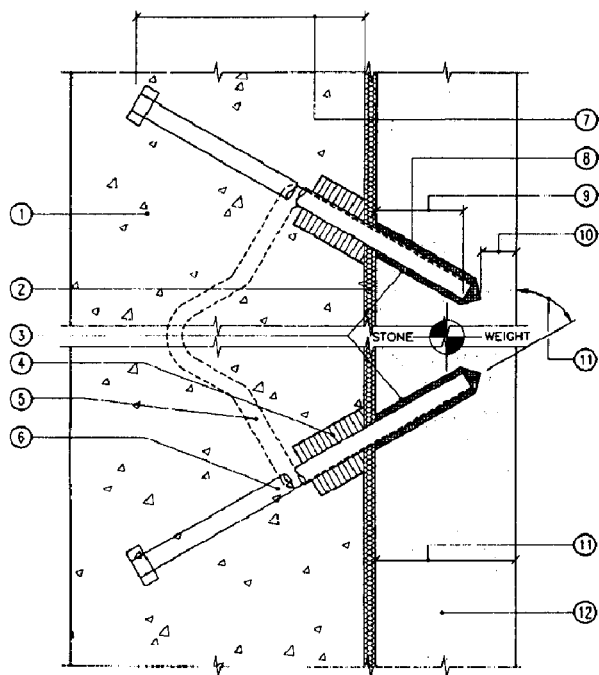

ANCHOR IN HORIZONTAL OR VERTICAL PLANE CAN SUPPORT GRAVITY AND LATERAL LOADS. (PREFERRED ORIENTATION IS FIGURE AS PLAN VIEW)

- ① SUPPORT CAST-IN ANCHOR IN PRECAST CONCRETE PANEL OR GROUT POCKET IN BACKUP STRUCTURE. CONTROL DEFLECTION BETWEEN ANCHORS TO AVOID INDUCING STRESS IN PANEL.
- ② PREVENT ADHESION WITH CONTINUOUS POLYETHYLENE SHEET TO CREATE A BOND BREAKER. USE EXPANDED TYPE WHEN MOISTURE CAN OCCUR BETWEEN BACKUP AND CLADDING TO CREATE A COMPRESSIBLE CAVITY. PROTECT CAVITY FROM INFILTRATION AND ALLOW CAVITY TO DRAIN.
- ③ DRILL INCLINED HOLES INTO BACK OF PANEL USING NON-PNEUMATIC TOOL. HOLE DIAMETER TO BE 1/16 IN. (1.5 mm) MAX. LARGER THAN ANCHOR. SLANT-AND-OPPOSE DIRECTION OF HOLES IN HORIZONTAL PLANE INTO BACKSIDE OF PANEL (ALTERNATING DIRECTIONS) TO MECHANICALLY LOCK STONE PANEL ONTO BACKUP. ANGLE HOLES 35° TO 60° WITH FACE.
- ④ PLACE NEOPRENE GROMMET COLLAR ON ANCHOR. OUTSIDE DIAMETER IS TWO TIMES DOWEL DIAMETER AND LENGTH IS 5 TIMES DOWEL DIAMETER. FITS SNUG OVER SHANK OF PIN AND DOWEL, ALLOWING ANCHOR TO FLEX SLIGHTLY.
- ⑤ INSERT EACH END OF SPRING-PIN OR HAIR-PIN INTO TWO HOLES. 3/16 IN. (5mm) MINIMUM DIAMETER. ORIENT PINS IN HORIZONTAL PLANE. TAKE CARE TO VERIFY FULL EMBEDMENT AND ALIGNMENT BEFORE CASTING BACKUP.
- ⑥ INSERT END OF COMPATIBLE METAL DOWEL ANCHOR FULLY INTO HOLE. THREADED, OR SMOOTH ROD OR HEX BOLT 1/4 IN. (7mm) MINIMUM DIAMETER, ORIENT PINS IN HORIZONTAL PLANE.
- ⑦ VERIFY MINIMUM ANCHOR EMBEDMENT INTO BACKUP IS THE GREATER OF 2 1/2 IN. (60mm) OR TWICE THE EMBEDMENT IN THE PANEL (PART 9)
- ⑧ FILL HOLE WITH SEALANT, POLYESTER OR EPOXY RESIN TO PREVENT MOISTURE ACCUMULATION. SELECT FILL COMPATIBLE WITH ANCHOR TYPE, SPACING, STONE TYPE, ENVIRONMENT, AND NEED TO CUSHION BEARING OF DOWEL OR PIN ON SIDE OF HOLE.
- ⑨ EMBED DOWEL INTO PANEL MINIMUM 2/3 OF CLADDING THICKNESS UP TO 3 IN. (75 mm) THICK, OR 1/2 OF CLADDING THICKNESS FOR OVER 3 IN. (75 mm) THICK.
- ⑩ LEAVE MINIMUM COVER OVER DRILLED HOLE OF 3/8 IN. (10mm) TO HELP AVOID BLOW-OUT DURING DRILLING AND SPALLING OR SPOTTING FROM ABSORBED MOISTURE.
- ⑪ MAINTAIN 1/4 IN. (30 mm) NOMINAL MINIMUM CLADDING THICKNESS.
- ⑫ DIMENSION STONE CLADDING FACE PANEL.

FIG. 8 Cast-In Anchors

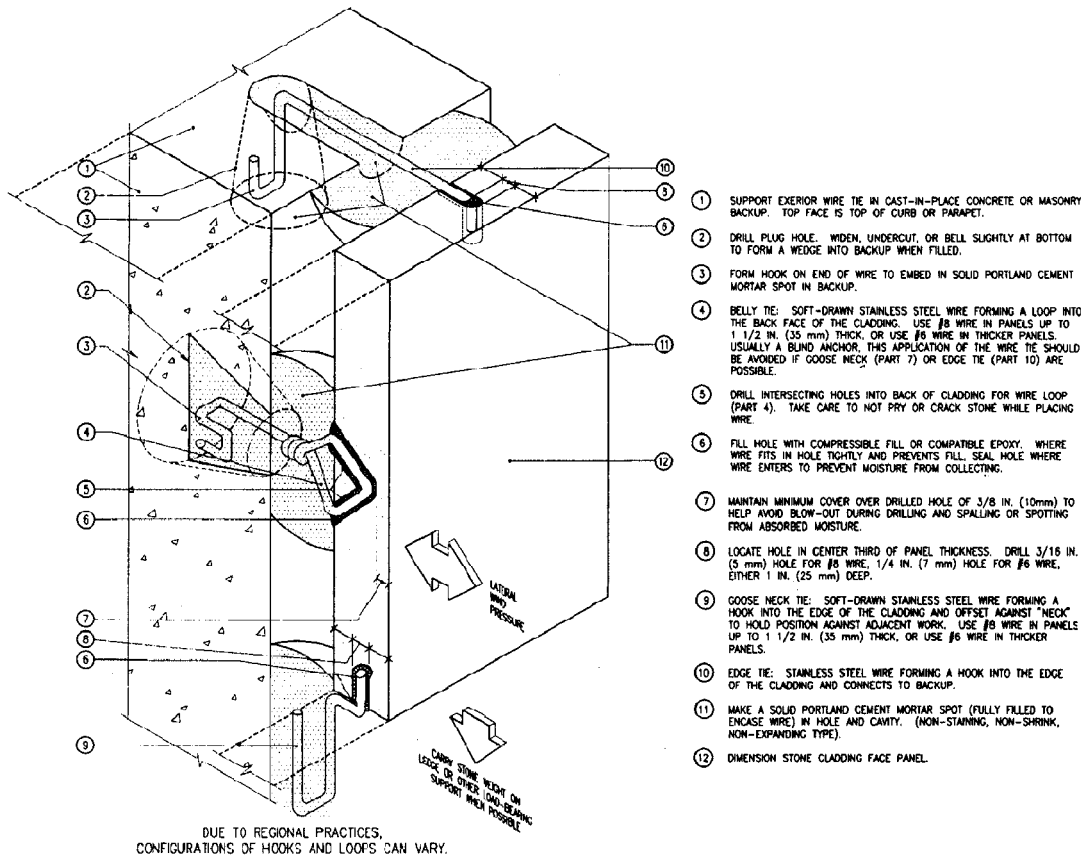

FIG. 9 Wire Ties

9.1.4 Cladding anchors should be uniformly distributed.

9.2 *Wire Ties* (see Fig. 9):

9.2.1 Wire ties used on vertical panels are intended to resist only lateral loads. Weight of vertical panels should be supported by bearing on a ledge, corbel, slot, shelf, or liner separate from the ties.

9.2.2 Wire ties with portland-cement based mortar spots can be used to attach stone cladding to cast-in-place concrete or masonry backup on exteriors. Wire ties with gypsum or molding plaster spots can be used to attach interior stone panels to backup.

9.2.3 Some stones are stained by mortar or plaster spots. Verify compatibility of spot, tie and stone materials before installing to avoid staining.

9.2.4 Wire ties can hook into the edge of a panel or wrap through intersecting holes drilled into the side, or back of the stone, or both. Looping wire ties through intersecting holes in the back of the stone allows anchors to remain hidden. Wire ties should hook into or mechanically fasten into the backup to act as a tensile tie to the stone. The spot needs to be tight between the backup and the stone to provide for compression transfer. Fill anchor holes with portland-cement based mortar or epoxy. Plaster may be used on interior applications to hold wire firmly in stone. Set stone and clamp in place until spots cure.

9.2.5 Number of wires should be minimum of two and a maximum of four per individual panel and should follow the general rules of 7.2. If Test Method C 1354 anchor testing or

panel bending showed more than four anchors were required, then the backup must be made stiffer than the stone panel.

9.2.6 Drill holes following guidelines of 9.1.4. Tie embedment into stone should follow the guidelines of 9.1.5. Depth of holes and edge distances should follow the guidelines of 9.1.6.

9.2.7 Minimum recommended wire diameter is 0.148 in. (4 mm) for exterior, 0.0808 in. (2 mm) for interior.

9.3 *Face Anchors*—Face anchors are basically through-bolted fasteners. Their main use currently is corrective in nature, as a reinforcement for stone experiencing anchor failure, although it has some potential as a decorative feature. In this use, a decorative plate or washer is exposed at the exterior face of the stone with a bolt either passing through this washer or welded to it. A backup plate or washer should also be used at the back of stone to transfer lateral loads to the through-bolt. The bolt is then passed through the backup wall and secured with a nut at the opposite face of the wall. The load is adequately distributed by a plate or the bolt is anchored into the backup structure.

9.4 *Blind Anchors*—Blind anchors are those not available for visual examination during and after anchorage installation and should not be used unless no other options exist.

9.5 *Liners*—Liners are pieces of stone or metal attached to the back of the stone. Their function is to transfer loads from the stone to an anchor. Connections between the liners and stone are through a mechanical connection. An adhesive bond is used only to facilitate attachment of the liner to the stone. The mechanical connection should consist of two or more

stainless steel fasteners per liner, set at a 30 or 45° angle both upward and downward from the back of the liner into the stone. The fasteners are installed after the liner adhesive has set. Liners can have a reglet cut into them to form a kerf to receive an anchor or can be square cut. Liners should be shop-installed by experience shop mechanics, preferably with controlled inspection. The fasteners should be pre-cut to calculated lengths, such that when fully inserted in the designed holes, their ends are visible at the face of the liner. This will provide the installer an opportunity to verify that the fasteners are in place and fully inserted. (See Fig. 10a-c.)

9.6 Code requirements must be considered as minimums and not as viable substitutes for a completely engineered stone cladding system.

10. Sealant Joints

10.1 Joints between stones should accommodate the following:

- 10.1.1 Stone dimensional tolerances,
- 10.1.2 Setting tolerances,
- 10.1.3 Dimensional changes in stone due to causes such as temperature changes, hysteresis, and moisture,
- 10.1.4 Building movement, such as column shortening and elongation, structural drift and twist and spandrel deflection,
- 10.1.5 Long-term effects caused by creep or plastic flow,
- 10.1.6 Anchors, and
- 10.1.7 Sealants and backer rod for correct sealant aspect ratio.

10.2 Horizontal joints usually accommodate more dimensional change than vertical joints.

10.3 Unrestrained movements within stone cladding normally cause no stress problems. Restraint imposed upon the movement of the cladding can result in excessive stress and eventual failure. Provision for soft, structurally open joints can prevent such failure.

10.3.1 A soft joint is one that precludes transfer of a load from an adjacent stone across a joint, provided each stone is individually anchored and, depending upon the sealant used, is usually dimensioned at two to four times the anticipated movement. For example, for an anticipated 3/16 in. (4.8 mm) of movement, use a joint width of 3/8 in. (9.5 mm) to 3/4 in. (19.1 mm). In some designs, stones are stacked to transfer gravity loads. In the case of unengineered walls, if these stacks are applied more than 30 ft (9.14 m) above the adjacent ground elevation, they should have horizontal supports spaced not over 12 ft (3.66 m) vertically above the 30-ft (9.14-m) height.

10.3.2 To maintain the unrestricted performance of a soft joint, the characteristics of the joint sealant should be considered.

10.3.3 Care should be exercised in the setting process to preclude the chance inclusion of hard materials in open joints. Resulting stress concentrations at restraint points can result in spalling of the stone or possible failure of the anchorage, or both.

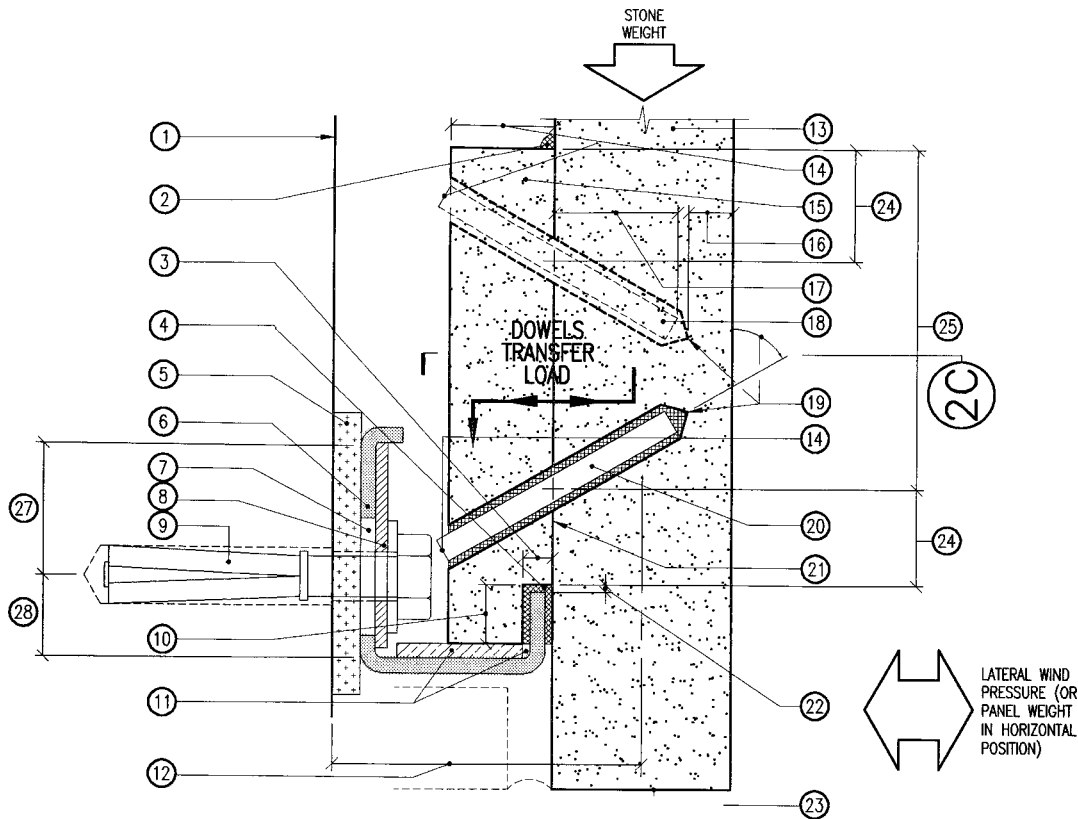

NOTE 1—Use where edge of stone is exposed or not accessible by anchor. Anchor beneath linear can support gravity and lateral loads (figure as section view). Anchor on side or top of liner can support only lateral loads (figure as plan or inverted section view).

FIG. 10 a: Stone Liner Block with Kerf

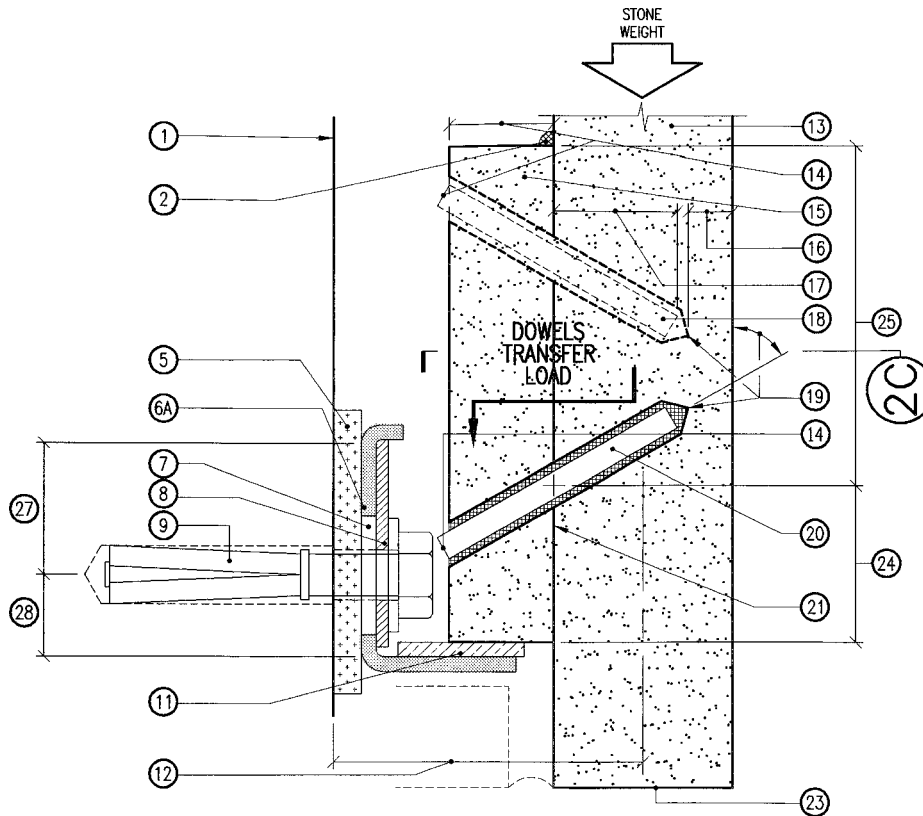

NOTE 1—Anchor is placed under liner block and can support only gravity loads (figure as section view). Provide lateral support with additional anchors. Parts 3, 4, 10, 22, and 26 are not used on Fig. 10b.

FIG. 10 b: Stone Liner Block without Kerf (continued)

11. Backup Structure

11.1 The backup structure is the means by which loads applied to the stone and anchors are transferred to the building's structure. This backup may be the building structure, a masonry wall, a metal strut system, or a prefabricated assembly. Whatever backup system is chosen, an understanding of the properties of that structure is prerequisite to the design of a cladding system. The design of the backup system should take into account gravity, wind, seismic, window, maintenance platform, shipping, and erection loads and the stone attachment means.

11.2 Stone Setting on Masonry Backup:

11.2.1 Masonry backup is appropriate (1) where the backup wall is part of the building design, such as a foundation, shear or bearing wall, (2) where a more dense masonry wall is required to reduce sound transmission, or as a protection from possible hazards, and (3) where the stone sizes or patterns are such that only a masonry wall is a practical backup wall. There are two general methods of setting stone on masonry backup: mortar set and dry set.

11.2.2 In a mortar set system, all stone joints are filled with mortar. Metal strap or rod anchors are used to attach all or portions of the stone to the backup. One end of the anchor is set into a sealant-filled hole or slot in the stone and the other is secured to the wall by suitable mechanical fasteners. The gravity load of the stone is carried by the foundation or relieving angles. A cavity is left between the back of the stone

and the backup. The anchor must be capable of transferring the wind load to the backup.

11.2.3 In a dry set system, the stone is attached to the backup by anchors with a cavity between the back of the stone and the backup wall. The stone joints are filled with nonrigid materials, such as gaskets or sealants. Because a cavity exists between the back of the stone and the backup wall, the anchors should be designed to accommodate the wind loads. This system is not practical for cladding with irregularly shaped, small, or rubble stones.

11.2.3.1 The gravity load is carried by the foundation or relieving angles. When the gravity load is carried by a relieving angle, each stone is laterally restrained with either strap or dowel anchors. Strap anchors are appropriate where the stone is stacked vertically or is resting on setting shims. These anchors should be designed with sufficient flexibility to compensate for differential movement in the structure, such as that which can occur between the stone and a masonry backup wall.

11.2.3.2 There are several ways for attachment of the anchor to the backup wall. Expansion bolts may be used in 75 % solid concrete masonry units. For hollow concrete masonry units used as backup walls, through bolts with fish plates should be used. The anchors may also be bolted to an intermediate structure, such as an angle, tube or channel which is in turn fastened to, or build into, a backup wall designed to carry such load.

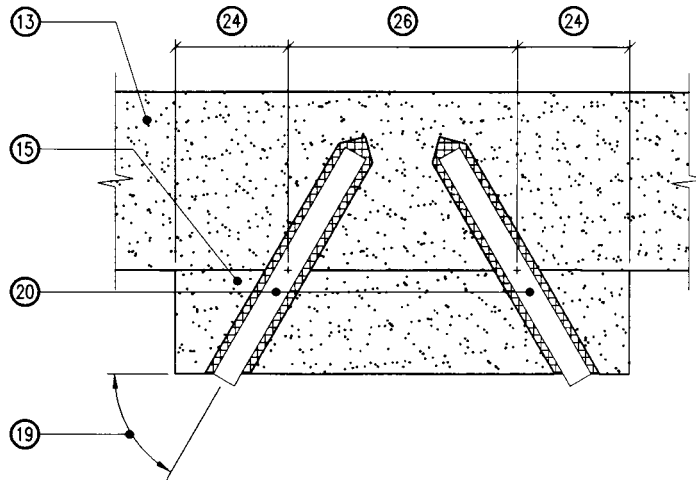

- ① SUPPORT ANCHORAGE ON COMPATIBLE, STABLE BACKUP.
- ② SEAL EPOXY FILLET ON TOP SIDE OF LINER WITH CAULK BEAD TO PREVENT CONDENSATION FROM ENTERING THE LAMINATION IF STONE ABSORPTION OR ENVIRONMENT RESULTS IN MOISTURE ON INSIDE OF PANEL.
- ③ SAWCUT REBATE IN EDGE OF STONE LINER BLOCK TO FORM A KERF WHEN ASSEMBLED ONTO FACE PANEL (PART 3). CLEAN EXCESS EPOXY FROM GROOVE IMMEDIATELY AFTER LAMINATION.
- ④ FILL KERF WITH COMPRESSIBLE MATERIAL TO HOLD PANEL POSITION AND CUSHION BEARING OF ANCHOR ON KERF.
- ⑤ ADJUST IN-OUT POSITION WITH PLASTIC OR METAL BEARING SHIM SLIGHTLY LARGER THAN ANCHOR'S FASTENED FACE. REQUIRED TO SEPARATE DISSIMILAR MATERIALS AND POSITION ANCHOR RELATIVE TO FRAMING. MINIMIZE THICKNESS TO MINIMIZE BENDING ON FASTENER (PART 9). THICKNESS AFFECTS FASTENER CAPACITY.
- ⑥ SUPPORT PANEL ON BACKUP (PART 1) WITH KERF ANCHOR. BRAKE-FORMED SHEET METAL, EXTRUDED, OR MODIFIED ROLLED SHAPE THAT IS NON-CORRODING AND FITS INTO SAWN KERF. AVOID MISALIGNMENT AND RESULTING PRYING ON CLADDING FROM INACCURATE FABRICATION OR INSTALLATION. SHOWN AS LATERAL PRESSURE AND WEIGHT SUPPORT.
- ⑥A SUPPORT PANEL WEIGHT ONLY ON BACKUP (PART 1) WITH SHELF ANGLE. BRAKE-FORMED SHEET METAL, EXTRUDED, OR MODIFIED ROLLED SHAPE THAT IS NON-CORRODING AND FORMS BEARING LEDGE. AVOID UNLEVELNESS AND RESULTING INSTABILITY FROM INACCURATE FABRICATION OR INSTALLATION. SHOWN AS WEIGHT SUPPORT ONLY.
- ⑦ ADJUST UP-DOWN POSITION OF ANCHOR (PART 6) RELATIVE TO BOTTOM OF LINER BLOCK (PART 15) WITH VERTICAL SLOT. ALLOWS FOR HEIGHT ADJUSTMENT AND FASTENER PLACEMENT TOLERANCES.
- ⑧ PREVENT SLIP OF THE CONNECTION AFTER VERTICAL ADJUSTMENT WITH DIAGONALLY SLOTTED WASHER PLATE, WELDED WASHER, OR SERRATED ANCHOR AND WASHER. DO NOT RELY ON FRICTION.
- ⑨ ATTACH ANCHOR TO BACKUP WITH FASTENER.
- ⑩ MINIMIZE KERF DEPTH. INCLUDING VARIANCES PER PART 22, MAINTAIN 3/8 IN. (10mm) MINIMUM ENGAGEMENT OR TESTED MINIMUM.
- ⑪ BEAR STONE ON PLASTIC OR NON-COMPRESSIBLE RUBBER SHIM FOR LEVELING, SEPARATION, AND TO PREVENT PRYING OF STONE KERF FIN ON ANCHOR RADIUS. MAINTAIN ADEQUATE ENGAGEMENT IN KERF (PARTS 3 AND 10). ADJUST ANCHOR VERTICALLY WITH PART 7, NOT SHIMS.
- ⑫ MINIMIZE DISTANCE TO MINIMIZE ECCENTRIC WEIGHT ON ANCHORAGE, TO REDUCE FASTENER (PART 9) PULLOUT AND KERF ANCHOR (PART 6) DISPLACEMENT.
- ⑬ DIMENSION STONE CLADDING FACE PANEL.
- ⑭ ENGAGE DOWELS IN LINER FULL DEPTH (THICKNESS) OF LINER BLOCK. PRECUT DOWEL ENDS TO BE EXPOSED AS SHOWN SO ENGAGEMENT CAN BE VERIFIED.
- ⑮ STONE LINER BLOCK. SAME MATERIAL AS FACE PANEL (PART 13). ANCHOR CAPACITY VARIES NONPROPORTIONALLY WITH LENGTH OF BLOCK, THICKNESS OF BLOCK AND QUANTITY OF DOWELS ENGAGED.
- ⑯ LEAVE MINIMUM COVER OVER DRILLED HOLE OF 3/8 IN. (10mm) TO HELP AVOID BLOW-OUT DURING DRILLING AND HELP PREVENT SPALLING OR SPOTTING FROM ABSORBED MOISTURE.
- ⑰ EMBED DOWEL INTO PANEL MINIMUM 2/3 OF CLADDING THICKNESS UP TO 3 IN. (75 mm) THICK, OR 2 IN. (50 mm) MINIMUM FOR CLADDING OVER 3 IN. THICK.
- ⑱ LOCK BLOCK WITH END CRAMPS OR SECONDARY DOWELS IN OPPOSING SLOPE TO PRIMARY DOWELS FULLY EMBEDDED IN APPROPRIATE EPOXY. PARTS TO BE NON-CORRODING METAL. REQUIRED ONLY IF PRIMARY DOWELS (PART 20) DO NOT OPPOSITELY SLANT TO, OR MECHANICALLY PREVENT BLOCK FROM DISENGAGING FROM FACE PANEL (PART 13) PER FIGURE 8C.
- ⑲ DRILL INCLINED-AND-OPPOSING DIRECTION HOLES OR TOENAILED HOLES IN HORIZONTAL PLANE THROUGH LINER (PART 15) INTO FACE PANEL (PART 13) FOR DOWELS (PARTS 18 AND 20). CLAMP DURING DRILLING AND DOWELLING.
- ⑳ TRANSFER LOAD FROM FACE PANEL (PART 13) TO LINER BLOCK (PART 15) WITH PRIMARY DOWELS FULLY EMBEDDED IN APPROPRIATE EPOXY. PARTS TO BE NON-CORRODING METAL. SLOPE IN DIRECTION OF LOAD OR TOENAIL UPWARDS AND HORIZONTALLY IN OPPOSITE ANGLES PER FIGURE 8C. DO NOT USE FASTENERS WITH EXPANDING SLEEVES IN LIEU OF DOWELS.
- ㉑ LAMINATE LINER BLOCK TO FACE STONE WITH COMPATIBLE EPOXY ADHESIVE. APPLY AFTER PROPER SURFACE PREPARATION. ALLOW TO CURE PROPERLY WITHOUT DISTURBING.
- ㉒ MAINTAIN CLEARANCE AT ROOT OF KERF TO AVOID POINT LOADING. ALLOW FOR SHIM VARIATIONS (PART 11), MOVEMENT, FABRICATION, AND INSTALLATION TOLERANCES.
- ㉓ EXPOSED BOTTOM EDGE THAT PREVENTS ANCHOR ACCESS TO EDGE.
- ㉔ KEEP DOWELS (PARTS 18 AND 20) 3/4 IN. (20 mm) MINIMUM FROM ROOT OF KERF (PER PART 10) AND EDGE OF BLOCK (PART 15).
- ㉕ HEIGHT OF BLOCK TO BE MINIMUM THREE TIMES EDGE DISTANCE (PART 24).
- ㉖ KEEP DISTANCE BETWEEN DOWELS (PARTS 18 AND 20) MINIMUM FOUR TIMES EMBEDMENT DEPTH (PART 17).
- ㉗ ESTABLISH MINIMUM ALLOWABLE BEARING HEIGHT ABOVE FASTENER (PART 9) TO CONTROL PULLOUT DUE TO LOADS PERPENDICULAR AND AWAY FROM FACE PANEL.
- ㉘ ESTABLISH MINIMUM ALLOWABLE BEARING HEIGHT BELOW FASTENER (PART 9) TO CONTROL PULLOUT DUE TO ECCENTRIC WEIGHT OF FACE PANEL(S) (PART 13).

NOTE 1—Parts 1–12, 14, 16–18, 21–23, 25, 27, and 28 are not used on Fig. 10c.

FIG. 10 c: Plan View Showing Horizontal Toenailing of Primary Dowels (continued)

11.2.3.3 Expansion bolts have limitations which should be considered in their use. Manufacturers of fasteners have conducted product testing and make test results available.

11.3 *Concrete and Masonry Backup Walls:*

11.3.1 Cast in place concrete backup walls are subject to shrinkage and expansion in the horizontal and vertical directions; the amount of dimensional change depends upon such factors as ambient temperature and humidity, mass, moisture content, reinforcement ratios, cement-to-aggregate ratios, and building height. These effects should be determined by the engineer of record. The greatest amount of dimensional change due to shrinkage usually occurs within the first eighteen months that the concrete is in place.

11.3.2 Concrete block walls are subject to shrinkage in both the horizontal and vertical directions. Reinforcement should evenly distribute the shrinkage. Dimensional changes usually occur within a month following the setting of the block.

11.3.3 Brick walls set with standard mortar are usually initially stable in dimension. However, bricks are subject to irreversible, net, long-term moisture, and freezing expansion in addition to reversible thermal expansion.

11.3.4 Terra cotta block backup walls are subject to expansion when wet and contraction when dry. It is possible for the expansion to continue through repeated wettings. If restraint to this expansion exists, the face of the wall can be deflected laterally.

11.4 *Metal Framing Systems:*

11.4.1 There are two types of frames: one composed of individual members fastened to the structure, usually referred to as struts, the other, a prefabricated assembly attached to the structure in large sections, usually referred to as trusses. Either system can be constructed of standard rolled structural sections or heavy-gage, galvanized, cold-formed sheet steel sections or aluminum sections prefabricated to suit the anchorage and building structural connections.

11.4.2 *Strut Systems:*

11.4.2.1 Struts are normally provided in floor height increments and usually not more than 15-ft (4.6-m) lengths.

11.4.2.2 The system should be designed for the maximum allowed deflection established by the engineer of record.

11.4.2.3 When struts expand vertically from floor to floor, a means should be provided for accommodating expansion and deflection in order to allow the strut to move independently of the struts placed above and below. To accomplish this, a horizontal expansion joint in the stone and backup structure is usually placed at or near the floor line.

11.4.2.4 Where the spandrel extends above and below the floor line, or from the floor line to the window head below, the required expansion joint is usually placed at, and as part of, the window head assembly.

11.4.2.5 Where spandrel and floor-to-floor strut systems interface, an expansion joint is required to accommodate differential movement.

11.4.2.6 Strut designs should consider the loads applied by contiguous window assemblies. This load data should be provided by the window fabricator and should include the amount of lateral displacement allowed in the window assembly at the head, sill, and combined assembly.

11.4.2.7 In the design of floor-to-floor struts, care should be taken to consider deflection of these struts under wind load. Lateral supports may be used above the ceiling line to shorten the unsupported height of the strut.

11.4.2.8 In the case of spandrel struts, rotation should be considered with the deflection check. It may be necessary to include a brace to either the bottom of the spandrel beam, if one exists, or to the slab behind. When a brace is applied to the floor slab, the floor structure should be checked for the effect of the applied load.

11.4.2.9 It is usually preferable to place the struts at fifthpoint locations behind each stone panel, though placement at other locations may be required due to the stone jointing pattern or lateral load factors. Placement of the struts at joint locations can reduce the number of struts by 50 %, but the decision to do so should take into consideration a requirement for longer and stronger shelf angles, thicker stone, or both. As with the requirement for proper structural analysis of the anchorage, a similar analysis is required for strut placement.

11.4.3 *Truss Systems:*

11.4.3.1 Prefabricated metal truss assemblies enable early closure of a building and offer good insulating capability. This lighter weight can be a major consideration in high-rise buildings and when seismic loading must be considered. This method of stone backup lends itself to the development of prefabricated facade configurations of almost any complexity.

11.4.3.2 The truss should be fabricated in accordance with AISC specifications and finished for corrosion prevention. The stone can be fixed to the truss at the truss fabrication shop. An alternative would be to ship the truss to another location and fix the stone to the truss there.

11.4.3.3 Trusses can be designed in floor height or structural bay width sizes, or both. In the floor height or combined configuration, the design is similar to that used for individual floor-to-floor struts except that provisions should be included for resistance to racking of the truss from transportation and installation loads and building structure movements. In the bay width design, additional complexities may be encountered due to elastic deflection in the slab edge, rotation of the supporting spandrel beam, or long-term effects such as creep in concrete structures.

11.4.3.4 Compared to the stone it supports, a metal truss is laterally more flexible under wind load. This factor should be considered when analyzing the structural behavior of the assembly under load.

11.4.3.5 Suspension of the truss from, or at, the columns should limit deflection.

11.4.3.6 Any loads from windows or other contiguous building components that might be transferred to the truss assembly should be accommodated in the design of the truss.

11.4.3.7 Truss assemblies are often designed with large areas and resultant large weights. This suggests consideration of redundant building connections to preclude catastrophic failure of the entire truss assembly in the event of a primary truss connection failure. These redundant connections can be part of the truss lateral bracing or can be separate connections.

11.4.3.8 Loading tests done on mockups are to be carried to a multiple of design load and hold time. Such test loads and

hold times are to be determined by the architect or engineer of record. Each connection on the truss must perform as expected under these conditions without permanent set. Anchors should be load tested to confirm calculated performance predictions. The need for separate stone tests are discussed elsewhere in this guide.

11.5 Precast Concrete Backup:

11.5.1 Precast concrete backup systems are used to permit faster enclosure, allowing earlier work by other trades and subsequent earlier occupancy. Attachment of the system to the building can be accomplished completely off the floor and does not require elaborate temporary scaffolding.

12. Water Infiltration

12.1 Regardless of the care taken to preclude water intrusion behind stone cladding by the use of joint design or sealants, it should be accepted that leakage will occur during the lifetime of the building. A secondary defense should be established to preclude the entrapment of this water and subsequent intrusion into the interior of the building. This is best accomplished through the use of flashing and weeping.

12.1.1 Provided that fire safing does not interfere, the provision for flashing and weeping should be provided at each floor or some multiple of floors. A maximum of two floor multiples, or 25 ft (7.6 m) is suggested. Weeps at the flashing should be spaced horizontally approximately 16 to 24 in. (40.6 to 61.0 cm) apart. Often, weeps are placed at joint intersections where there will be no interference from anchors and where the weep tubes can be easily encapsulated with sealant.

12.1.2 The cavity between the back of the stone cladding and the backup structure should be vented to remove vapor through the use of vents. The size and number of the vents should be determined by the design engineer.

12.1.2.1 The weep and vent tube should have an outside dimension that can be accommodated in the joint width. Rope or felt wicks can also perform the function of the weep.

12.1.2.2 The vapor vent tubing should run vertically behind the stone to a height that will prevent wind-driven rain from intruding into the cavity. (See Fig. 11.)

12.1.3 Much of the water vapor occurring behind a stone cladding derives from the higher humidity of the building's interior. A proper vapor barrier should be provided as part of the exterior wall backup system, extending from the floor slab to the slab or structure above, and from window unit to window unit, completely isolating the exterior wall cavity from the interior.

12.1.4 Failure to provide an effective vapor barrier will allow condensate to form on the interior side of the stone, which can become entrapped in kerfs and holes, possibly leading to freeze-thaw cycling failures that can destroy the

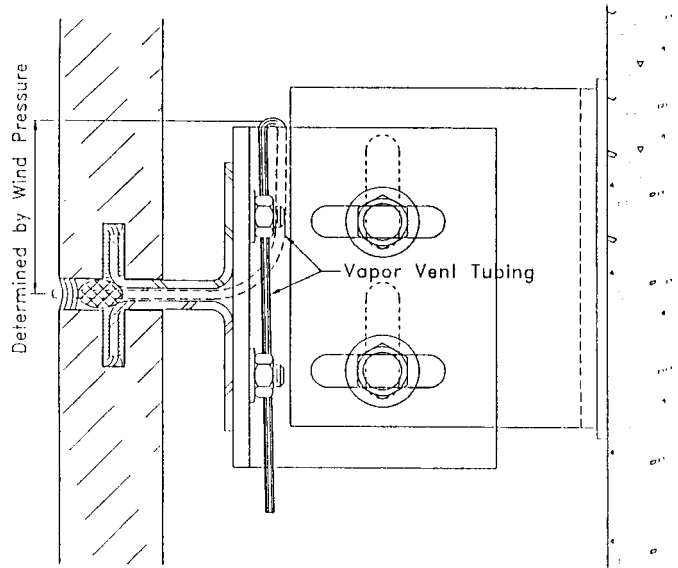

FIG. 11 Vapor Vent Tubing

integrity of the stone at the anchorage points. Further, the condensate can lead to the deterioration of sealants through sealant subsurface liquification and to the corrosion of steel. Even if no structural failure occurs, entrapped condensate can migrate to the face of the stone and cause staining.

12.1.5 The joint sealant is the primary defense against water intrusion but cannot be relied upon to provide a waterproof barrier. The sealant should be carefully chosen and specified. Several types are available, each with its own characteristics regarding adhesion, cohesion, elongation, lifespan, modulus, and color. Oil-based and non-skinning sealants should not be used due to the probability of staining the stone or themselves becoming stained. Adhesion of properly selected and applied sealant to the stone is usually not a problem. However, adhesion to adjacent surfaces may become a problem. Certification by the sealant manufacturer of the suitability of the product for the intended application should be obtained prior to its use on the work. The recommendation of the manufacturer should be followed regarding the possible requirement for priming the surface of these materials. It is strongly recommended that a test panel be erected in the field at least one month, preferably three or more, prior to job application, as a step toward confirming performance.

13. Keywords

13.1 anchor types; backup; consultants; design considerations; design process; exemplar; joints; materials of construction; stone anchors; stone installation; stone testing; water infiltration

ASTM International takes no position respecting the validity of any patent rights asserted in connection with any item mentioned in this standard. Users of this standard are expressly advised that determination of the validity of any such patent rights, and the risk of infringement of such rights, are entirely their own responsibility.

This standard is subject to revision at any time by the responsible technical committee and must be reviewed every five years and if not revised, either reapproved or withdrawn. Your comments are invited either for revision of this standard or for additional standards and should be addressed to ASTM International Headquarters. Your comments will receive careful consideration at a meeting of the responsible technical committee, which you may attend. If you feel that your comments have not received a fair hearing you should make your views known to the ASTM Committee on Standards, at the address shown below.

This standard is copyrighted by ASTM International, 100 Barr Harbor Drive, PO Box C700, West Conshohocken, PA 19428-2959, United States. Individual reprints (single or multiple copies) of this standard may be obtained by contacting ASTM at the above address or at 610-832-9585 (phone), 610-832-9555 (fax), or service@astm.org (e-mail); or through the ASTM website (www.astm.org).