



Standard Test Method for Capillary-Moisture Relationships for Fine-Textured Soils by Pressure-Membrane Apparatus¹

This standard is issued under the fixed designation D 3152; the number immediately following the designation indicates the year of original adoption or, in the case of revision, the year of last revision. A number in parentheses indicates the year of last reapproval. A superscript epsilon (ϵ) indicates an editorial change since the last revision or reapproval.

1. Scope

1.1 This test method covers the determination of capillary-moisture properties of fine-textured soils as indicated by the moisture content - moisture tension relationships determined by pressure-membrane apparatus using tensions between 1 and 15 atm (101 and 1520 kPa). Moisture tension (matrix suction) is defined as the equivalent negative gage pressure, or suction, in soil moisture. The test result is a moisture content which is a measure of the water retained in the soil subjected to a given soil - water tension (or at an approximately equivalent height above the water table).

NOTE 1—For determination of capillary-moisture relationships of coarse- and medium-textured soils, refer to Test Method D 2325.

1.2 *This standard does not purport to address all of the safety problems, if any, associated with its use. It is the responsibility of the user of this standard to establish appropriate safety and health practices and determine the applicability of regulatory limitations prior to use.*

2. Referenced Documents

2.1 ASTM Standards:

- D 421 Practice for Dry Preparation of Soil Samples for Particle-Size Analysis and Determination of Soil Constants²
- D 698 Test Method for Laboratory Compaction Characteristics of Soil Using Standard Effort (12,400 ft-lbf/ft³ (600 kN-m/m³))²
- D 2325 Test Method for Capillary-Moisture Relationships for Coarse- and Medium-Textured Soils by Porous-Plate Apparatus²

3. Summary of Test Method

3.1 Saturated soil samples are placed in contact with a saturated porous membrane resting on a screen disk installed within a high-pressure chamber. The bottom of the membrane-screen assembly is maintained at atmospheric pressure by means of a small drain tube or opening through the bottom of the pressure chamber. A desired air pressure admitted to the

pressure chamber, and consequently to the top of the membrane, creates a pressure drop across the membrane. The saturated soil samples on the membrane establish equilibrium with the water in the membrane. The water, held at a tension less than the pressure drop across the membrane, will then move out of the soil, through the membrane, and out through the drain hose. When water has ceased to flow from the sample and the membrane, indicating equilibrium for that particular tension, the moisture content of each sample is determined. A series of these tests at various tensions is required to prepare a complete curve of the capillary-moisture properties for any particular soil.³

4. Apparatus (see Fig. 1)

4.1 *Pressure-Membrane Chamber*—A pressure chamber consisting of a space ring about 305 mm (12 in.) in diameter and about 13 mm ($\frac{1}{2}$ in.), 51 mm (2 in.), or 102 mm (4 in.) high, with heavy top and bottom steel plates 482 MPa (70 000 psi) tensile strength; the top and bottom plates shall be held tightly against O-ring gaskets on the spacer ring by heavy-duty $\frac{5}{8}$ -in. bolts. A rubber diaphragm 1.6 mm ($\frac{1}{16}$ in.) thick shall be cemented to the top plate.

NOTE 2—This equipment is available from several commercial firms.

NOTE 3—Chamber should have safe pressure strength of 2.07 MPa (300 psi). The test should be made in a constant-temperature room or cabinet, maintained at a temperature of 20°C (68°F), with a relative humidity of at least 50 %.

4.2 *Pressure Source*—Compressed air or nitrogen in cylinders, or a high-pressure compressor. Nitrogen should be used if solutions extracted are to be analyzed chemically.

4.3 *Pressure Manifold*—A U-tube containing 266 g of mercury, used to maintain a pressure differential of about 28 ± 7 kPa (4 ± 1 psi). (See flow diagram and photograph in Fig. 1.)

4.4 *Cellulose Membrane*—Cellulose sausage case, usually seamless tubing about 6 m (20 ft) long and about 152 mm (6 in.) wide.

4.5 *Sample Retainer Rings*—Rigid plastic rings 10.2 mm (0.4 in.) in height and of 50.8 mm (2 in.) inside diameter, with a wall thickness of approximately 3.0 mm (0.12 in.), capable of holding approximately 25 g of disturbed sample. Similar rings

¹ This test method is under the jurisdiction of ASTM Committee D18 on Soil and Rock and is the direct responsibility of Subcommittee D18.04 on Hydrologic Properties of Soil and Rock.

Current edition approved Dec. 29, 1972. Published March 1972.

² *Annual Book of ASTM Standards*, Vol 04.08.

³ This test method is modified from Richards, L. A., 1947, *Pressure-Membrane Apparatus—Construction and Use: Agricultural Engineering*, Vol 28, pp. 451–454.

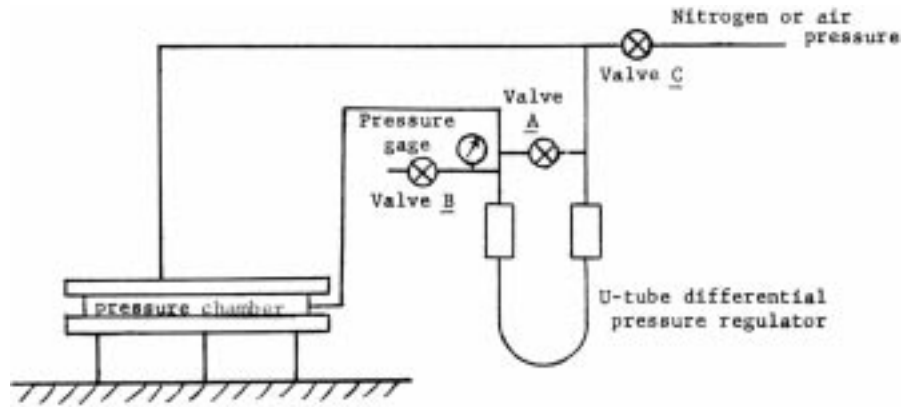

Flow diagram



FIG. 1 Suggested Pressure-Membrane Apparatus

of other materials also may be used or undisturbed samples may be retained in sections of their sampler liners. The rings are numbered in pairs; for example, A1, A'1, A2, A'2, etc.

4.6 *Test Specimen Cutter*—A cylindrical ring with a sharp cutting edge beveled on the outer edge of one end. The inside diameter shall be 51 mm (2 in.) and the height shall be 25 mm (about 1 in.). A metal blank 51 mm (2 in.) in diameter and 13 mm (about 1/2 in.) thick, with a detachable handle, shall be available.

4.7 *Spatula*, short, wide blade (or small pancake turner), for removing samples from pressure plates.

4.8 *Test Specimen Packer Disk*—A flat steel disk 49.0 mm

(1.93 in.) in diameter and 3.2 mm (1/8 in.) thick that can be loaded to 9000 g.

NOTE 4—A pocket-type penetrometer has been found convenient for loading the disk.

4.9 *Surcharge Weights*—Brass disks, 49.0 mm (1.93 in.) in diameter and 17.7 mm (0.7 in.) in diameter.

4.10 *Torque Wrench*, capable of exerting a torque of at least 6.8 N·m (5 lbf·ft) on apparatus bolts.

4.11 *Moisture Sample Containers*, of 60 to 90-mL (2 to 3-oz) capacity, made of material resistant to corrosion, and not subject to change in weight or disintegration on repeated

heating and cooling. Containers shall have close-fitting lids to prevent loss of moisture from samples before initial weighing and to prevent absorption of moisture from the atmosphere following drying and before final weighing. One container is needed for each moisture content determination. The containers shall be numbered in pairs to coincide with the retainer rings.

4.12 *Saturation Tray*—Waterproof tray about 25 mm (1 in.) in depth and large enough to hold the circular membrane while it is being saturated thereon.

4.13 *Balance*, with a capacity of at least 200 g and sensitive to 0.01 g.

4.14 *Desiccator*, of suitable size to hold samples for cooling after removal from the oven.

4.15 *Oven*, thermostatically controlled, capable of maintaining temperatures at $110 \pm 5^\circ\text{C}$ ($230 \pm 9^\circ\text{F}$).

4.16 *Trimmers*—Wire saw, beveled straightedge, spatula, and other small tools for trimming the test specimen.

4.17 *Control Samples*—Disks of porous stone with standard sample dimensions; or, pour and pack in a retainer ring a sample consisting of a fine-textured soil.

5. Samples

5.1 Prepare duplicate samples from specimens cut from undisturbed or remolded samples, or from specimens packed from loose disturbed samples.

5.2 *Preparation of Test Specimens from Disturbed Samples:*

5.2.1 Take a sample weighing about 25 g from the thoroughly mixed portion of the air-dried soil passing the No. 10 (2.00-mm) sieve, which has been obtained in accordance with Practice D 421.

5.2.2 Pour each sample into a retainer ring, pack, and level to fill the ring by pressing the top surface with the test specimen packer disk, using an applied force of 9000 g.

5.3 *Preparation of Test Specimens from Undisturbed Samples:*

5.3.1 Cut a block of material, at least 76.2 mm (3 in.) on each side, to be prepared, with two faces plane and parallel. Determine and record the natural moisture content and dry unit weight of the sample block. Also record the direction (perpendicular or transverse) of the sampling in relation to structural or depositional layers.

5.3.2 Place the test specimen cutter, with the cutting edge downward, on top of one of the plane faces and force cutter down lightly and gradually, as excess material is trimmed from the outside, using the minimum pressure required on the cutter. The trimming motions shall be from the cutter outward and downward, providing a column of soil slightly larger than the outside diameter of the cutting edge. When the cutter is more than one-half full of soil, remove the excess at the bottom with the wire saw, invert the cutter, and use the straightedge to make the soil flush with the cutting edge. Invert the cutter again, place it on the smooth face of the metal blank, and carefully force the cutter downward until the blank is flush. Remove the excess soil at the top with the wire saw, true the end with the straightedge, and remove the blank by means of the detachable handle.

5.3.3 Center the specimen cutter, with the specimen downward over the retaining ring, and use the metal blank to insert

the test specimen gently into the ring.

5.3.4 Maintain the samples in the closed containers until time for testing.

5.4 *Preparation of Test Specimens from Remolded Samples:*

5.4.1 Compact the sample to a density and moisture content desired for anticipated service conditions in accordance with Test Methods D 698.

5.4.2 After the remolded sample has been ejected from the compaction mold, cut the test specimen by the process used for undisturbed samples, in accordance with 5.3.1-5.3.4.

6. Procedure

6.1 Cut a piece of cellulose membrane as long as the outside diameter of the pressure chamber. Split open one side of the membrane and soak it thoroughly in the saturation tray. This soaking helps eliminate the possibility of leaks caused from small cracks formed by the handling of the membrane while it is stiff and brittle. Cut the membrane to the size and shape of the outside of the apparatus spacer ring. Install the membrane on the screen in the pressure chamber, and place the spacer ring with the gasket in position on top of the membrane. Trim the excess membrane off by running a knife around the outside of the spacer ring.

NOTE 5—Care must be taken to keep soil particles away from the O-ring (lower gasket) of the pressure chamber; otherwise puncturing of the membrane may result from trapped sand grains when the top is clamped down. Place a ring of moist cheesecloth just inside the spacer ring to assist in keeping particles away from the gasket.

6.2 Place duplicate samples, prepared as described under 5.2, 5.3, and 5.4, diametrically opposite each other on the membrane or, preferably, in two different pressure-membrane units, and record the ring number opposite the sample number on the report form. Note the sample type (disturbed, undisturbed, or remolded) on the report form. Place a retainer ring in the center of the membrane for a control sample.

6.3 Thoroughly saturate the samples by pouring $\frac{1}{8}$ in. (3.2 mm) of distilled water on the membrane and gradually increasing the depth of water over a minimum period of 4 h until the water is at the top edge of the sample. Maintain the water at this depth for at least 24 h. Place the surcharge weights on top of the samples during the soaking period.

6.4 Remove excess water from the membrane with a suction hose or rubber syringe. Carefully center the chamber top on the spacing ring with the O-ring gasket in place. Tighten all bolts to a uniform tightness of 5.4-6.8 N·m (4 to 5 lbf·ft) by means of a torque wrench. Connect a small rubber tube from the drain in the bottom of the pressure chamber to a graduated buret.

6.5 Regulate the air compressor or gas pressure source to the proper pressure for the tension desired.

6.6 Close valve *B* and open valve *A* on the regulator (Fig. 1). This admits compressed air to both sides of the diaphragm at the desired pressure.

6.7 After a few hours, the water outflow rate decreases appreciably. Because the samples now have sufficient rigidity to resist deformation or compaction, a 27.6-kPa (4-psi) pressure differential should now be applied to the rubber diaphragm at the top of the pressure chamber by closing valve *A*. As dehydration of the sample is accompanied by shrinkage, this

step is taken to keep the sample in constant contact with the bottom membrane.

6.8 Open valve *B* until air is heard bubbling through the mercury in the U-tube. Then close valve *B*. Adjust the pressure at the compressor or gas pressure tank to obtain the desired pressure (Table 1), as indicated on the pressure gage near valve *B*.

6.9 Remove the samples anytime after the outflow into the graduated buret has ceased, indicating that equilibrium has been reached.

NOTE 6—Most soils will attain equilibrium in approximately 24 h for 10-mm (0.4-in.) high samples, but some may take as much as 48 h. Thicker samples will take longer.

6.10 Release the air pressure in the pressure chamber by closing valve *C* to stop the source of pressure, opening valve *A* to reduce blowing of the mercury, and then opening valve *B*. Remove the top from the chamber. Do not set the top diaphragm-side down on the table as the diaphragm may be punctured by soil particles.

6.11 By means of the wide-blade spatula, transfer the samples immediately to the sample containers and immediately weigh the containers on a balance. Record this weight of wet sample plus container (W_{csw}) on line 3 of the report form (Fig. 2).

TABLE 1 Pressure Conversion Factors

[1 atm = 760 mm Hg (0°C) = 14.7 psi = 406.8 in. H₂O (39.2° F) = 10 330 mm H₂O (4°C)]

Tension, atm	Equivalent Pressure		Capillary Head (m of water)
	psi	mm Hg	
1	14.7	760	10.33
2	29.4	1520	20.67
3	44.1	2280	31.00
4	58.8	3040	41.33
5	73.5	3800	51.67
6	88.2	4560	62.00
7	103	5320	72.33
8	118	6080	82.66
9	132	6840	93.00
10	147	7600	103.33
11	162	8360	113.66
12	176	9120	124.00
13	191	9880	134.33
14	206	10 640	144.66
15	221	11 400	155.00

6.12 Dry the samples in the containers to constant weight in an oven at $110 \pm 5^\circ\text{C}$ ($230 \pm 9^\circ\text{F}$). Weigh the samples and record the weights of oven-dry samples plus containers (W_{cs}) on the report form.

6.13 Follow the above procedure until moisture contents have been obtained for at least 3 different tensions between 1 and 15 atm (101 and 1520 kPa).

NOTE 7—Because oven-drying may affect the results for samples containing clay minerals, new samples should be used for each tension. If this is not possible, the wet weight should be obtained and the sample should be replaced in the chamber for the next *higher* tension, obtaining an oven-dry weight at the end of the series of tension.

7. Calculation

7.1 Calculate the moisture content of the soil as follows:

$$w = [(W_{csw} - W_{cs}) / (W_{cs} - W_c)] \times 100 = (W_w / W_s) \times 100 \quad (1)$$

where:

- w = moisture content, %,
- W_{csw} = weight of container and wet sample, g,
- W_{cs} = weight of container and dry sample, g,
- W_c = weight of container, g,
- W_w = weight of water, g,
- W_s = weight of dry soil, g.

7.2 The moisture content in volume % may be obtained by multiplying the moisture content by the dry unit weight (in grams per cubic centimetre) of each test specimen and dividing by the unit weight of water.

8. Report

8.1 Report the moisture content, tension data, and calculations on a form similar to Fig. 2.

8.2 Plot the moisture contents and tension data on a graph similar to Fig. 3. Extend the curve to the moisture content equivalent to 100 % saturation on the zero tension line.

NOTE 8—If desired, the moisture data also can be converted to moisture content in volume % or to the degree of saturation, but this should be clearly identified on the graph.

9. Keywords

9.1 capillary-moisture; fine-textured soils; pressure-membrane

Capillary-Moisture Relations for Soils

Location: _____ Sample No.: _____
 Depth: _____ Date: _____ Ring No.: _____
 Identification: _____ Soil type: _____
 Initial natural moisture content: _____ %; Sample type: _____
 Initial natural weight: _____ g/cm³; _____ lb/ft³; Porosity: _____ %
 Void ratio: _____; Specific gravity: _____
 Remarks: _____

(1) Tension, _____

(2) Container number _____

(3) Wt of container + wet sample (W_{csw}), g _____

(4) Wt of container + dry sample (W_{cs}), g _____

(5) Wt of moisture (W_w), g (3 - 4) _____

(6) Wt of container (W_c), g _____

(7) Wt of dry sample, (W_d), g (4 - 6) _____

(8) Moisture content (ω), % (5 ÷ 7) × 100 _____

(9) Unit wt of dry sample (γ_d) _____

(10) Moisture content by volume (ω_v) % (8 × 9) _____

FIG. 2 Laboratory Form for Capillary-Moisture Relations for Soils

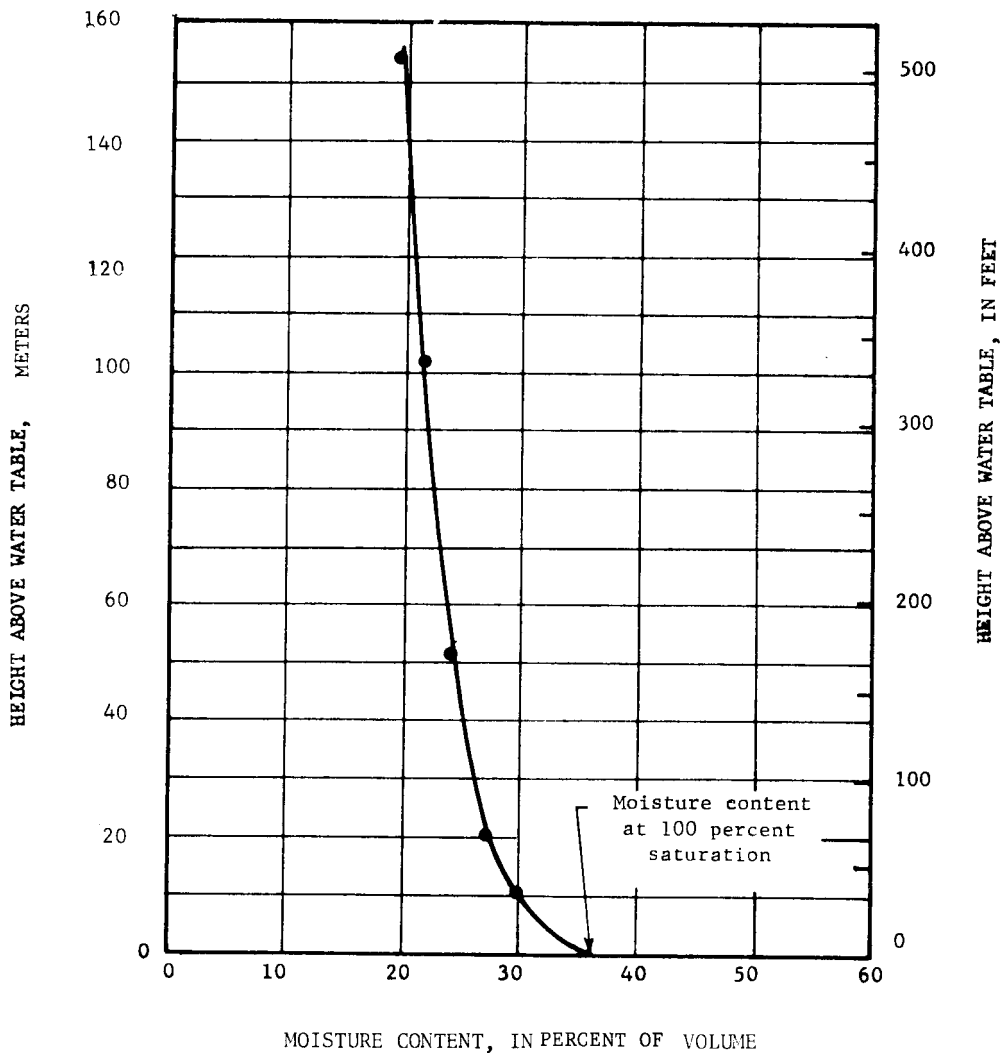

FIG. 3 Example of Data on Capillary-Moisture Relations of Soils

The American Society for Testing and Materials takes no position respecting the validity of any patent rights asserted in connection with any item mentioned in this standard. Users of this standard are expressly advised that determination of the validity of any such patent rights, and the risk of infringement of such rights, are entirely their own responsibility.

This standard is subject to revision at any time by the responsible technical committee and must be reviewed every five years and if not revised, either reapproved or withdrawn. Your comments are invited either for revision of this standard or for additional standards and should be addressed to ASTM Headquarters. Your comments will receive careful consideration at a meeting of the responsible technical committee, which you may attend. If you feel that your comments have not received a fair hearing you should make your views known to the ASTM Committee on Standards, at the address shown below.

This standard is copyrighted by ASTM, 100 Barr Harbor Drive, PO Box C700, West Conshohocken, PA 19428-2959, United States. Individual reprints (single or multiple copies) of this standard may be obtained by contacting ASTM at the above address or at 610-832-9585 (phone), 610-832-9555 (fax), or service@astm.org (e-mail); or through the ASTM website (www.astm.org).