



Standard Test Methods for Sampling and Testing Electrical Insulating Board¹

This standard is issued under the fixed designation D 3394; the number immediately following the designation indicates the year of original adoption or, in the case of revision, the year of last revision. A number in parentheses indicates the year of last approval. A superscript epsilon (ε) indicates an editorial change since the last revision or reapproval.

1. Scope

1.1 These test methods cover the sampling and testing of electrical insulating boards. These boards are porous, usually fibrous sheets used for dielectric and structural purposes in electrical apparatus.

1.2 These test methods are not intended for testing vulcanized fibre or molded laminated sheets.

1.3 These test methods are applicable to board materials having a nominal thickness of at least 0.030 in. (0.76 mm).

NOTE 1—For materials thinner than 0.030 in. (0.76 mm) see Test Methods D 202.

1.4 The test methods appear in the following sections:

	Sections	ASTM Method Reference
Apparent Density	18-23	
Aqueous Extract Characteristics	36-42	D 202
Ash Content	43-46	T 413
Compatibility with Dielectric Liquids	47-52	D 664, D 877, D 924, D 971, D 974, D 1169, D 1500, D 1816, D 3455, D 3487
Compressibility	79-85	
Conditioning	11	D 685
Degree of Polymerization	86-89	D 4243
Dielectric Strength in Air	53-59	D 149
Dielectric Strength in Oil	60-65	D 149, D 2413, D 3426
Dimensions of Sheets	12-17	
Moisture Content	31-35	D 644
Oil Absorption	72-78	
Reports	10	
Sampling	6-9	D 3636
Shrinkage	24-30	D 644
Tensile Properties	66-71	D 202

1.5 The values stated in inch-pound units are to be regarded as the standard.

1.6 *This standard does not purport to address all of the safety concerns, if any, associated with its use. It is the responsibility of the user of this standard to consult and establish appropriate safety and health practices and determine the applicability of regulatory limitations prior to use.*

2. Referenced Documents

2.1 ASTM Standards:

- D 149 Test Method for Dielectric Breakdown Voltage and Dielectric Strength of Solid Electrical Insulating Materials at Commercial Power Frequencies²
- D 202 Test Methods for Sampling and Testing Untreated Paper Used for Electrical Insulation²
- D 374 Test Methods for Thickness of Solid Electrical Insulation²
- D 586 Test Method for Ash in Paper³
- D 644 Test Method for Moisture Content of Paper and Paperboard by Oven Drying³
- D 664 Test Method for Acid Number of Petroleum Products by Potentiometric Titration⁴
- D 685 Practice for Conditioning Paper and Paper Products for Testing³
- D 877 Test Method for Dielectric Breakdown Voltage of Insulating Liquids Using Disk Electrodes⁵
- D 924 Test Method for Dissipation Factor (or Power Factor) and Relative Permittivity (Dielectric Constant) of Electrical Insulating Liquids⁵
- D 971 Test Method for Interfacial Tension of Oil Against Water by the Ring Method⁵
- D 974 Test Method for Acid and Base Number by Color-Indicator Titration⁴
- D 1169 Test Method for Specific Resistance (Resistivity) of Electrical Insulating Liquids⁵
- D 1500 Test Method for ASTM Color of Petroleum Products (ASTM Color Scale)⁴
- D 1816 Test Method for Dielectric Breakdown Voltage of Insulating Oils of Petroleum Origin Using VDE Electrodes⁵
- D 2413 Test Methods for Preparation and Electrical Testing of Insulating Paper and Board Impregnated with a Liquid Dielectric²
- D 2865 Practice for Calibration of Standards and Equipment for Electrical Insulating Materials Testing⁶
- D 3426 Test Method for Dielectric Breakdown Voltage and Dielectric Strength of Solid Electrical Insulating Materials Using Impulse Waves⁶
- D 3455 Test Methods for Compatibility of Construction

¹ These test methods are under the jurisdiction of ASTM Committee D09 on Electrical and Electronic Insulating Materials and are the direct responsibility of Subcommittee D 09.19 on Dielectric Sheet and Roll Products.

Current edition approved Jan. 15, 1994. Published March 1994. Originally published as D 3394 – 75. Last previous edition D 3394 – 86ε¹.

² Annual Book of ASTM Standards, Vol 10.01.

³ Annual Book of ASTM Standards, Vol 15.09.

⁴ Annual Book of ASTM Standards, Vol 05.01.

⁵ Annual Book of ASTM Standards, Vol 10.03.

⁶ Annual Book of ASTM Standards, Vol 10.02.

Materials with Electrical Insulating Oil of Petroleum Origin⁵

D 3487 Specification for Mineral Insulating Oil Used in Electrical Apparatus⁵

D 3636 Practice for Sampling and Judging Quality of Solid Electrical Insulating Materials⁶

D 4243 Method for Measurement of Average Viscometric Degree of Polymerization of New and Aged Electrical Papers and Boards⁶

E 29 Practice for Using Significant Digits in Test Data to Determine Conformance with Specifications⁷

2.2 *TAPPI Standard:*

T 413 Determination of Ash in Paper⁸

3. Terminology

3.1 *Description of Term Specific to This Standard:*

3.1.1 *electrical insulating board*—a sheet structure, usually composed of cellulosic fibers, utilized for dielectric or structural purposes or both in a variety of electrical apparatus. Board is herein arbitrarily differentiated from paper in that it is at least 0.030 in. (0.76 mm) thick and is manufactured only in sheets of limited length. Other names for these products are pressboard, transformer board, fuller board, and press pan.

4. Summary of Test Methods

4.1 This standard is a compilation of test methods for electrical insulating board. Provisions are included for sampling, testing, and judging acceptability of a given quantity of board.

5. Reagents

5.1 Reagents shall conform to the requirements set forth in Test Methods D 202.

SAMPLING

6. Scope

6.1 This test method covers the determination of lot acceptability of electrical insulating board. It is designed for the purpose of determining acceptability of all or that portion of a shipment to a customer identified by a manufacturer's lot number. It is not intended to cover internal board mill quality control plans. The method is intended for use in conjunction with product specifications for electrical insulating board.

7. Terminology

7.1 *Descriptions of Terms Specific to This Standard:*

7.1.1 The descriptions of terms used in this test method, with the exception of the definition of "unit of product," are in accordance with Practice D 3636.

7.1.2 *unit of product*—an entity of electrical insulating board on which one or more quality characteristics may be determined. A unit of product may be a sheet, pallet, box, carton, case, package, or bundle. The unit of product is

established by the customer and may or may not be the same as the unit of purchase, supply, production, or shipment.

8. Establishing Acceptable Quality Levels (AQLs)

8.1 Acceptable quality levels (AQLs) for each major and minor property (as defined in Practice D 3636) shall be as mutually agreed upon between the purchaser and the seller. In addition, group AQLs may be established for given groups of properties and these too shall be mutually agreed upon between the purchaser and the seller.

9. Selection of Sample and Identification of Lot Sample

9.1 Samples shall be in accordance with Practice D 3636, with the exception of those paragraphs pertaining specifically to rolls, pads, or bobbins.

9.2 Mark each unit of the sample so that it may be identified at any time by the seller and the purchaser.

REPORTS

10. Report

10.1 At the completion of all tests record the results in a test report that includes the following:

10.1.1 Identification (of the board sampled and tested) by lot number, type, grade, etc.,

10.1.2 Dates of testing,

10.1.3 Location of the testing laboratory and the name of the person responsible for testing,

10.1.4 Remarks indicating the method used and any deviation from the standard,

10.1.5 Test results as specified in the individual method, and

10.1.6 Specification limits for each property measured for the board being tested.

10.2 Report the results as calculated or observed values rounded to the nearest unit in the last right-hand place of figures used in the material specification to express the limiting value (see Practice E 29).

CONDITIONING

11. Conditioning

11.1 Condition samples and specimens cut from the samples (with the exception of samples taken for moisture determination or as otherwise specified) in a circulating-air atmosphere maintained at 50 ± 2 % relative humidity and a temperature of $23 \pm 2^\circ\text{C}$, using procedures as specified in Method D 685.

11.2 For referee purposes, the conditioning specified in 11.1 will give most consistent results. However, for routine testing under factory or other non-standard atmospheric conditions, if the board has a moisture content within the range from 5 to 7 % as determined in Sections 31-34, there will be only slight variations from properties as determined after conditioning specified above.

DIMENSIONS OF SHEETS

12. Apparatus

12.1 *Scale*—A scale of suitable length graduated such that lengths, widths, and diagonals can be directly read to within

⁷ Annual Book of ASTM Standards, Vol 14.02.

⁸ Available from Technical Association of the Pulp and Paper Industry, One Sunwoody Park, Atlanta, GA 30338.

half of the allowable tolerance for these dimensions. The scale shall be properly calibrated in accordance with Practice D 2865.

12.2 *Thickness-Measuring Device*—Machinist micrometer with ratchet as specified in Test Methods D 374.

13. Sampling

13.1 Sample in accordance with Sections 6-9.

14. Test Specimens

14.1 Specimens for determination of length, width, and squareness of sheets shall be whole sheets. For thickness determinations, a whole sheet may be used or, if desired, a portion of a whole sheet will serve as a specimen. If a portion is selected as a specimen for thickness determination, that portion shall be representative of the full width (cross-grain direction) of the sheet.

14.2 Determine the dimensions as received, provided the moisture content is in the specification range for the material being tested (see 11.2).

15. Procedure

15.1 Measure the length and the width of each specimen to the nearest appropriate unit. Make at least two measurements in each direction.

15.2 Measure each of the two diagonals of each specimen.

15.3 Measure the thickness in accordance with Test Methods D 374, Method A. Make at least five thickness determinations across the sheet.

NOTE 2—Points of measurement should be selected to include the areas most likely to be the extremes.

16. Report

16.1 The report shall conform to Section 10 and shall include the following:

16.1.1 Sheet size, reported as the average of the measurements in each direction.

16.1.2 Squareness of the sheet, reported as the quotient of the shorter diagonal divided by the longer diagonal (for convenience, squareness is expressed as a percent).

NOTE 3—This method of calculating squareness assumes that the sheet closely approximates a parallelogram in shape. If measurements of width or length vary at different points, it is possible that a high squareness value may be calculated from measurements on a sheet that differs significantly from being rectangular.

16.1.3 Average thickness, and

16.1.4 Variation in thickness, reported as the difference between the highest and the lowest thickness value obtained in 15.3.

17. Precision and Bias

17.1 The precision and bias of this test method are not known.

APPARENT DENSITY

18. Scope

18.1 This test method may be used for determination of apparent density of insulating board, using measurements of dimensions and weight made after appropriate conditioning.

18.2 Procedures are given for determining either the “wet-wet” or the “dry-dry” density.

19. Significance and Use

19.1 Apparent density affects the dielectric and physical characteristics of insulating board and is a factor in the economics of its use in apparatus. This test is useful for specification, design, and quality control purposes.

20. Apparatus

20.1 *Scale or Calipers*, graduated in units of length, with the smallest graduation equal to, or less than, 0.25 % of the smallest dimension to be measured, calibrated in accordance with Practice D 2865.

20.2 *Balance*, graduated in units of weight, with the smallest graduation equal to, or less than, 0.25 % of the specimen weight, calibrated in accordance with Recommended Practice D 2865.

20.3 *Thickness-Measuring Device*, conforming to the requirements of Test Methods D 374, Method A.

20.4 *Oven*, conforming to the requirements of Test Method D 644.

21. Procedure

21.1 From each unit of product in the sample obtained in accordance with Sections 6 through 9, prepare at least two rectangular specimens having an area of at least 75 in.² (0.05 m²) each.

21.2 *Procedure A: Wet-Wet Density*—Condition the specimens in accordance with Section 11.

21.3 *Procedure B: Dry-Dry Density*—Dry the specimens to constant weight in an oven at 105 ± 3°C, in accordance with Test Method D 644. Cool to room temperature, using a desiccator or other means to prevent reabsorption of moisture. Exposure to the open air while making the measurements specified in 21.4 shall be sufficiently brief that there will not be a weight increase of more than 0.1 % of the oven-dry weight of the specimens.

21.4 Measure the width, length, and thickness in accordance with Section 15 to determine the weight of each specimen.

21.5 From the dimensions and weight of each specimen, calculate the apparent density and report the results in units of grams per cubic centimetre, calculated as follows:

$$\text{Apparent density, g/cm}^3 = \frac{\text{weight} \times \text{factor}}{\text{volume}} \quad (1)$$

Weight Units	Volume Units	Factor
g	cm ³	1
g	in. ³	0.0610
lb	in. ³	27.68

22. Report

22.1 The report shall be in accordance with Section 10, and include the individual results for the apparent density of each specimen.

23. Precision and Bias

23.1 The precision and bias of this test method are not known.

SHRINKAGE

24. Significance and Use

24.1 The dimensions of electrical insulating boards will change as a function of moisture content, which varies with changes in the ambient relative humidity or as a result of heat or vacuum used in drying operations. The suitability of a board for some particular applications may be affected by the magnitude and direction of these dimensional changes.

24.2 The dimensional changes resulting from oven drying of specimens that have been conditioned under specified humidity conditions are used in this method as a measure of the shrinkage characteristics. This method is useful for design purposes, for specifications, and for some special control purposes.

25. Test Specimens

25.1 Cut square or rectangular pieces having dimensions of at least 3 in. (76 mm) in the plane of the sheet. The dimensions in the plane of the sheet may be determined by measuring either the overall distances between smoothly finished edges, or the distances between benchmarks on one face of the specimen. The optimum size of the test specimen will be determined by the method used for measuring the dimensions, and by the size of the conditioning chamber available.

26. Conditioning

26.1 Unless otherwise specified, condition the specimens to equilibrium with a standard atmosphere as specified in Section 11.

27. Procedure

27.1 Measure the dimensions of the specimens in the grain direction, the cross direction, and the thickness, in accordance with Sections 12-16. Make the measurements in the atmosphere in which conditioning was performed, or within 3 min of removal from that atmosphere.

27.2 Dry the specimens to constant weight at 105°C, and cool to room temperature in accordance with Test Method D 644.

27.3 Measure the dimensions of the specimens in accordance with 27.1.

28. Calculation

28.1 From the average dimensions before and after drying in each of the three directions, calculate the linear shrinkage in each of the three directions as a percentage of the respective initial dimensions.

29. Report

29.1 The report shall be in accordance with Section 10, and shall include the average shrinkage for each specimen in the grain direction, the cross direction, and the thickness.

30. Precision and Bias

30.1 The precision and bias of this test method are not known.

MOISTURE CONTENT

31. Significance and Use

31.1 Moisture content of electrical insulating board is important for economic and technical reasons. Many physical and dimensional characteristics of board are affected by moisture content and moisture content history. This test is useful for specification and quality control use. (For a more complete treatise on the significance of moisture content, see STP 60 B Paper and Paperboard—Characteristics, Nomenclature, and Significance of Tests.⁹)

32. Procedure

32.1 From a sample obtained in accordance with Sections 6-9 take carefully protected specimens and determine the moisture content in accordance with Test Method D 644. Take specimens from the test units and place immediately in a moisture-proof container, transport to a laboratory, and weigh immediately prior to oven drying.

33. Calculation

33.1 Calculate the moisture content of the board as follows:

$$\begin{aligned} \text{Moisture content, \%} \\ = (\text{weight loss on drying} \times 100 / \text{original weight}) \end{aligned} \quad (2)$$

34. Report

34.1 The report shall be in accordance with Section 10, and shall include the high, low, and average moisture content of the lot of board.

35. Precision and Bias

35.1 The precision and bias of this test method are not known.

AQUEOUS EXTRACT CHARACTERISTICS

36. Summary of Test Method

36.1 Procedures are specified for the preparation of aqueous extracts and for determination of their characteristics, including conductivity, pH, free acidity and alkalinity, and soluble chloride content.

37. Significance and Use

37.1 Water-soluble extractives, such as ionizable acids, bases, salts, or combinations thereof may degrade insulating qualities of board. Excessive quantities may lower the insulation resistance and may cause corrosion or degradation of the board under electric stress. Many of these impurities can be detected and their amounts estimated from measurements of conductivity, pH, free acidity or alkalinity, and chloride content of aqueous extracts of the board.

38. Apparatus

38.1 The apparatus shall be as specified in Test Methods D 202 for the corresponding tests.

⁹ Available from ASTM Headquarters, 1916 Race St., Philadelphia, PA 19103.

39. Test Specimens

39.1 In preparing specimens for the tests in 40.1-40.3, cut the board into pieces as small as possible, consistent with minimal handling and exposure. In the case of specimens from thick, high-density boards, extend the maceration time to 10 min if needed to pulp the specimen completely.

40. Procedure

40.1 *Acidity-Alkalinity-pH*—Test in accordance with Test Methods D 202.

40.2 *Conductivity*—Test in accordance with Test Methods D 202.

40.3 *Chloride Content*—Test in accordance with Method A of Test Methods D 202, except before refluxing, macerate the specimen for 5 min, using the same apparatus and procedure used to prepare aqueous extracts for pH measurements (40.1).

41. Report

41.1 The report shall be in accordance with Section 10 and shall include the following:

41.1.1 Test procedure used, and

41.1.2 Results of each test, including results of tests on blanks.

42. Precision and Bias

42.1 The precision and bias of the test for acidity-alkalinity-pH, and of conductivity are not known.

42.2 For the precision of the test for chlorides see Test Methods D 202. No statement can be made as to the bias of the chloride test, since a standard reference sample does not exist.

ASH CONTENT

43. Significance and Use

43.1 The presence of fillers, pigments, and mineral or metallic contaminants may affect the properties and performance of boards used for electrical insulation. This test provides a rapid means for determination of the amount of material present that is incombustible and nonvolatile under the conditions of test.

43.2 The presence of significant amounts of incombustible material is generally undesirable for cellulosic board and material specifications ordinarily specify an upper limit on the ash content.

43.3 This method is suitable for control testing, research, and specification purposes.

44. Procedure

44.1 Take test specimens from samples gathered in accordance with Sections 6 to 9. Test two specimens from each test unit.

44.2 Determine the ash content in accordance with TAPPI Method T 413, except use $575 \pm 25^\circ\text{C}$ for the ashing temperature.

45. Report

45.1 The report shall be in accordance with Section 10, and with the Report Section of Test Method D 586.

46. Precision and Bias

46.1 For the precision and bias of this method see TAPPI T 413.

COMPATIBILITY WITH DIELECTRIC LIQUIDS

47. Scope

47.1 This test method detects the presence of extractable contaminating substances in electrical insulating board by the measurement of changes in selected properties of a liquid after contact with the board under specified condition.

47.2 This method also provides for measurement of the effect of the liquid on the board by observation of changes in board properties after exposure to the liquid under specified conditions.

48. Significance and Use

48.1 Liquid-filled electrical apparatus uses refined mineral oil or other liquids which may be adversely affected by contaminants in boards. This method is useful for determining the effect of liquids upon board properties and the effect of board contaminants upon liquid properties. The method is useful for comparison of materials, for routine control, and for specification purposes.

48.2 It is not intended that this method be used as a measure of the thermal capability of the board, the liquid, or the combination thereof. The specified time and temperature are selected so that the test is a measure of the soluble contaminants in the sample, with no significant thermal degradation of either the board or the liquid. Caution must be exercised if either the time or the temperature is increased, as the influence of mechanisms other than solvent extraction may begin to affect the test results.

49. Sampling and Specimen Preparation

49.1 Sample in accordance with Sections 6-9.

49.2 Unless otherwise specified, the test specimen shall consist of 40 g of board, cut into pieces of convenient size to place into the immersion container so that liquid will cover all pieces of the specimen.

49.2.1 If property changes of the board on immersion are to be determined, the test specimens shall be of such dimensions as to be suitable for the measurement of the desired properties.

49.2.2 Care shall be taken to prevent contamination during preparation of the specimens.

49.2.3 If specimen weights other than 40 g are to be used, the specimen weight and dimensions shall be reported.

50. Procedure

50.1 Determine the compatibility with mineral insulating oil in accordance with Test Methods D 3455.

50.2 Unless otherwise specified, use uninhibited mineral oil meeting the requirements of Specification D 3487, Type I.

50.3 Other liquids may be used, if desired, with appropriate modification of Test Methods D 3455 made and noted in the report.

50.4 Unless otherwise specified, properties of the dielectric liquid to be measured shall include:

50.4.1 *Dissipation Factor (100°C)*—Determine in accordance with Test Method D 924.

50.4.2 *Resistivity (100°C)*—Determine in accordance with Test Method D 1169.

50.4.3 *Dielectric Breakdown Voltage*—Determine in accordance with Test Method D 877 or D 1816, as agreed.

50.4.4 *Neutralization Number*—Determine in accordance with Test Method D 974 or D 664.

50.4.5 *Interfacial Tension*—Determine in accordance with Test Method D 971.

50.4.6 *Color*—Determine in accordance with Test Method D 1500.

50.5 Determine the effect of liquid exposure on the board by measuring specified properties after exposure and comparing these values with those obtained on specimens of the board in its initial condition.

50.5.1 Board properties of particular interest after exposure include: shrinkage in accordance with Sections 24-30.

51. Report

51.1 The report shall be in accordance with Section 10 and with the applicable sections of Test Methods D 3455.

51.2 The report shall include a qualitative appraisal of the visual appearance or other noteworthy conditions of the board specimens after the liquid exposure, whether quantitative test data are required or not.

52. Precision and Bias

52.1 The precision and bias of this test method are not known.

DIELECTRIC STRENGTH IN AIR

53. Significance and Use

53.1 This test method provides a basis of comparison for board to be used in the untreated state, but the values in the test may not be directly related to voltage strength in use, which must be based upon experience in the intended application. For board that is subsequently impregnated or treated, this method may be useful in quality control to provide one indication of continuity of physical characteristics and the presence of contaminants. Such test values are of very limited use in predicting the results on impregnated board.

54. Apparatus

54.1 The apparatus shall conform to that specified in Test Method D 149. Use brass or stainless steel cylindrical electrodes 2 in. (51 mm) in diameter and 1 in. (25 mm) thick with edges rounded to ¼ in. (6 mm) radius (Type 1 of Table 1, Test Method D 149).

55. Test Specimens

55.1 Prepare test specimens from samples obtained in accordance with Sections 6-9.

55.2 Specimens shall be in accordance with Test Method D 149. For most materials, 6 in. (150 mm) square specimens will be adequate in size. For Conditions *A* and *C*, prepare sufficient specimens for five tests. For Condition *B*, prepare sufficient specimens for five tests (plus three specimens for

determination of moisture content, unless the moisture content is to be determined on the dielectric test specimens).

56. Conditioning

56.1 *Condition A*—Condition the specimens as specified in 11.1 prior to testing. Conduct the tests in the atmosphere specified in 11.1.

56.2 *Condition B*—Specimens to be tested without special conditioning. Take care that the moisture content specimens are given the same exposure as the dielectric strength specimens, so that the moisture content specimens, at the time that their original weights are measured shall have the same moisture content as the dielectric test specimens at the time of dielectric testing.

NOTE 4—It is acceptable to use three dielectric test specimens as moisture content specimens, weighing these specimens immediately before running the dielectric tests as specified in Section 57.

56.3 *Condition C*—Dry the specimens to constant weight at 105°C and cool to room temperature prior to testing. While awaiting the test, protect the specimens from reabsorption of moisture by placing them in a desiccator or by wrapping each tightly in a film or foil moisture barrier compatible with the temperature of the specimen. Complete the tests on the specimens within 24 h after they are removed from the oven.

57. Procedure

57.1 Make five tests of dielectric strength as specified in Test Method D 149, using the Short-Time Test.

57.1.1 If the average breakdown voltage is approximately 5000 V or less, increase the voltage at a rate of 250 ± 50 V/s.

57.1.2 If the average breakdown voltage exceeds 5000 V, increase the voltage at a rate of 500 ± 100 V/s.

57.1.3 In the case of a series of tests on specimens from similar samples averaging approximately 5000 V breakdown, make all tests at 250 V/s.

57.2 All specimens shall be flat over the area covered by the electrodes. If the board being tested tends to warp during conditioning (especially Condition *C*) it is usually helpful to hold the specimens under light pressure between wire screens during conditioning.

57.3 For specimens tested under Condition *B*, determine the moisture content of the three specimens, as specified in Sections 31-35.

58. Report

58.1 The report shall be in accordance with Section 10 and the Report Section of Test Method D 149.

58.2 Report which conditioning method was used, and for Condition *B*, the moisture content at the time of testing.

59. Precision and Bias

59.1 The precision and bias of this test on these materials are not known. See the Precision and Bias Section of Test Methods D 149 for more information in general on this test.

DIELECTRIC STRENGTH IN OIL

60. Significance and Use

60.1 The dielectric strength in oil is more indicative of the voltage strength in use than is the dielectric strength in air for

board to be used in a liquid dielectric. However, it must be realized that these test results are only comparative, and cannot be used to accurately determine directly the voltage stress which can be safely applied in service. Refer to the Significance and Use sections of Test Method D 149 for power-frequency tests or of Test Method D 3426 for impulse-voltage tests.

61. Apparatus

61.1 For power-frequency tests use apparatus for applying and measuring voltage as specified in Test Method D 149.

61.2 For impulse-voltage tests use apparatus for applying and measuring voltage as specified in Test Method D 3426.

61.3 Unless otherwise specified in the specification or other document calling for this test use Type 6 electrodes as described in Table 1 of Test Method D 149 (25/75 mm cylinders).

62. Procedure

62.1 Prepare the specimens, and dry, impregnate, and test them in accordance with Test Methods D 2413.

62.2 Unless otherwise specified, determine the dielectric strength at power frequency, using the rapid-rise method of voltage application, as specified in Test Method D 149.

62.3 When impulse-voltage testing is specified, apply the test voltage in accordance with Test Method D 3426.

63. Calculation

63.1 Make calculations in accordance with Test Methods D 2413 and Test Methods D 149 and D 3426.

64. Report

64.1 Report in accordance with Section 10 of this test method, Test Methods D 2413, and Test Methods D 149 or D 3426, as applicable.

65. Precision and Bias

65.1 The precision of this test method is not known. Refer to the precision and bias sections of Test Methods D 149, D 2413, and D 3426 for discussions of the factors influencing the precision of this type of measurement.

65.2 This test method has no bias, as the dielectric strength of electrical insulating board in oil is defined in terms of this method.

TENSILE PROPERTIES

66. Significance and Use

66.1 Boards may be subjected, during fabrication or in service, to various types of steady or fluctuating tensile stresses. These may include tensile stresses occurring near one surface or the other as a result of flexural loading. The tensile properties of the board are indicative of the suitability for use where such stresses may be applied.

66.2 The tensile properties of a board may be measured in connection with a thermal aging test, as an indication of changes occurring in the board as a result of exposure to the test environment.

66.3 The significance of the various tensile properties will depend upon the application for which the board is intended, or upon the purpose of the test program in which this method is used. See the significance statement in the appropriate sections of Test Methods D 202.

67. Sampling

67.1 Sample in accordance with Sections 6-9.

68. Test Specimens

68.1 Cut specimens from samples conditioned as specified in Section 11. Store and test in a standard atmosphere.

68.2 Cut at least ten specimens in each of the principal directions of interest, with clean and parallel edges. The specimens shall be preferably 1.00 ± 0.04 in. (25 ± 1 mm) in width, and of sufficient length to be gripped in the jaws of the testing machine, with a 8.0 ± 0.1 -in. (200.0 ± 2.5 -mm) separation at the start of the test.

NOTE 5—In order to obtain smooth, square edges on specimens from samples of thick or high-density boards, it may be necessary to shear or saw the specimens oversize, then machine to the finished width.

69. Procedure

69.1 Determine the tensile strength, elongation, and tensile energy absorption (TEA) as specified in the method for Tensile Properties in Test Methods D 202.

70. Report

70.1 The report shall be in accordance with Section 10, and the appropriate sections of Test Methods D 202.

70.1.1 Report tensile strength in units of force per unit of cross-sectional area of test specimen.

70.1.2 When TEA is measured and reported, also report the average thickness of the test specimens.

71. Precision and Bias

71.1 Refer to the applicable sections of Test Methods D 202.

OIL ABSORPTION

72. Scope

72.1 This is a test method for determining the weight of insulating oil absorbed by dried specimens of board during a vacuum impregnation operation. Within this method the word "oil" may be considered to include any dielectric liquid.

73. Significance and Use

73.1 The oil absorption is related to the density of the board and to its porosity. Deviations from the expected oil absorption of a board of a given density may be an indication of unusual formation or of the presence of noncellulosic constituents in the board.

74. Specimens

74.1 From each sample, taken as specified in Sections 6-9, prepare three specimens, each 3 ± 0.25 in. (76 ± 6 mm). The edges of the specimens may be either sheared or sawed, but must be free of loose particles which might become dislodged during the test.

75. Procedure

75.1 Dry the specimens to a constant weight in a circulating air oven at $105 \pm 2^\circ\text{C}$. A 24-h period is generally adequate for drying boards up to 0.125 in. (3 mm) nominal thickness with density of less than 1.1 g/cm^3 . For thicker or higher density boards the time required should be verified for the particular material by making two or more measurements of weight after drying for different times.

75.2 Remove the specimens from the drying oven, place them in a desiccator, and allow them to cool to room temperature.

75.3 After the specimens are cool, but within 6 h after removal from the drying oven, weigh each specimen to the nearest 1 mg.

75.4 Place the specimens, separated from each other, into a heated vacuum chamber. Raise the temperature to $90 \pm 5^\circ\text{C}$ and reduce the absolute pressure to 133 Pa (1 Torr) or less. Maintain these conditions for at least 2 h.

75.5 Slowly admit degassed oil preheated to 70 to 90°C to the vacuum chamber so as to cover completely the specimens. Do not permit the absolute pressure to rise above 266 Pa (2 Torr) while adding the oil. Unless otherwise specified, the oil shall conform to Specification D 3487, Type I or II.

75.6 After the specimens are completely immersed, break the vacuum and discontinue the application of heat. Allow the specimens to cool in the oil for at least 6 h or until the oil temperature has dropped to below 36°C .

75.7 Remove the specimens from the oil and blot off the excess oil with paper towels or blotting paper taking care to remove only the excess oil. Weigh each specimen and record the weight of the absorbed oil. Weighing shall be performed so as to weigh to the nearest 1 mg.

76. Calculation

76.1 For each specimen calculate the percentage of the oil absorbed as 100 times the ratio of the weight of oil absorbed to the dried unimpregnated weight of the board specimen.

76.2 Calculate the average of the oil absorption values from the data obtained on all specimens tested.

76.3 The amount of oil absorbed may also be calculated as a percentage of the theoretical maximum oil absorption. The latter may be estimated as:

$$\text{Oil absorption, \%} = 100 S_0 \left(\frac{1}{\bar{W}} - \frac{1}{\bar{F}} \right) \quad (3)$$

where:

- S_0 = density of the oil at room temperature, g/cm^3 ,
 \bar{W} = apparent density of the dried board, g/cm^3 , calculated from the mass of the dried specimen and the dimensions of that specimen as measured immediately after weighing, and
 \bar{F} = density of the fibers in the board, g/cm^3 (1.53 for cellulose).

77. Report

77.1 The report shall be in accordance with Section 10 and include the average, minimum, and maximum values of oil absorption for each sample.

78. Precision and Bias

78.1 The precision and bias of this test method are not known.

COMPRESSIBILITY

79. Scope

79.1 This test method covers procedures for measuring changes in thickness of board resulting from exposure to specified conditions of heat and compressive loading.

79.2 The two procedures cover measuring the short-time compressibility at room temperature of previously dried specimens, and measuring the thickness change resulting from longer-time (24 h) loading at elevated temperature.

80. Significance and Use

80.1 In many applications boards are subjected to compressive loading as part of the insulation and mechanical support structure of apparatus such as transformers. This method provides procedures for measuring changes in thickness resulting from compressive loading. Values obtained from these tests may be used for quality control, research, or design purposes.

81. Test Specimens

81.1 Prepare two specimens from each sample, taken as specified in Sections 6-9.

81.2 The specimens shall consist of a stack of rectangular (or square) pieces of board. The pieces shall have smooth, sheared, or sawed edges, free of burrs or loose fragments, and shall have an area of from 1.0 to 9.0 in.² (650 to 5800 mm²) with a width of at least 1.0 in. (25 mm). The width and length of all pieces shall be uniform within ± 0.01 in. (0.25 mm) of the nominal values.

81.3 Each specimen shall be made up of sufficient pieces to form a stack with a height of from one to two times the width of the pieces of board in the stack, but not more than 3.5 in. (89 mm).

82. Procedure

82.1 Drying:

82.1.1 Dry the pieces making up the test specimens to equilibrium in an air oven at $105 \pm 2^\circ\text{C}$. For materials up to 0.125 in. (3.2 mm) thick equilibrium will be reached within 24 h. For thicker materials use weight measurements to determine when equilibrium is reached. Specimens shall not be heated for more than 48 h.

82.1.2 Cool the specimens in a desiccator or other container that will prevent a weight increase of more than 0.1 % prior to testing.

82.2 Procedure A:

82.2.1 Assemble the pieces of the specimen into a rectangular stack in the fixture or other device to be used for loading and measurement.

82.2.2 Apply a bedding pressure of 150 ± 10 psi (1.03 ± 0.07 MPa) to the specimen and hold for 5 min. Measure the specimen height (h_0).

82.2.3 Increase the load to 3000 ± 50 psi (20.7 ± 0.4 MPa) and hold for 5 min. Measure the specimen height (h_1).

82.2.4 Reduce the load to the bedding pressure of 150 psi. Hold for 5 min and measure the specimen height (h_2).

82.3 Procedure B:

82.3.1 Assemble the specimen into a fixture in which a load can be applied and sustained on the specimen.

82.3.2 Apply a bedding pressure of 150 ± 10 psi to the specimen and hold for 5 min. Measure the specimen height (h_0).

82.3.3 Increase the load to 3000 ± 50 psi and hold for 5 min. Measure the specimen height (h_1).

82.3.4 While still maintaining the 3000-psi compressive load, heat the specimens in an air oven at $105 \pm 2^\circ\text{C}$ for 24 ± 2 h.

82.3.5 Remove the fixture from the oven and cool to room temperature. Place the fixture in a desiccator, or otherwise protect the specimen from moisture while cooling.

82.3.6 Measure the height of the specimen (h_2).

82.3.7 Reduce the load to the bedding pressure of 150 psi. Hold for 5 min, and measure the specimen height (h_3).

82.4 The apparatus shown in Fig. 1 may be used to hold the specified compressive loads on the specimens. Other suitable fixtures may also be used.

83. Calculation

83.1 Procedure A—For each specimen calculate the following:

$$\text{Compressibility } (C) = [(h_0 - h_1)/h_0] \times 100 \% \quad (4)$$

$$\text{Set } (S) = [(h_0 - h_2)/h_0] \times 100 \%$$

83.2 Procedure B—For each specimen calculate the following:

$$\text{Compressibility } (C) = [(h_0 - h_1)/h_0] \times 100 \% \quad (5)$$

$$\text{High-Pressure Set } (S_h) = [(h_1 - h_2)/h_0] \times 100 \%$$

$$\text{Low-Pressure Set } (S_l) = [(h_0 - h_3)/h_0] \times 100 \%$$

84. Report

84.1 The report shall be in accordance with Section 10 and shall include the following:

84.1.1 Dimensions of the specimens,

84.1.2 Procedure used,

84.1.3 Individual and average values for compression and set as calculated in 83.1 or 83.2.

85. Precision and Bias

85.1 Duplicate specimens tested at the same time should give compressibility and set values differing by no more than 3 % of the percentage of compression.

85.2 Tests made on duplicate samples by different laboratories should give compressibility and set values differing by no more than 5 % of the percentage of compression.

VISCOMETRIC DEGREE OF POLYMERIZATION

86. Significance and Use

86.1 This test method is useful for the evaluation of samples of both new and aged boards. It is particularly helpful for research and other investigative purposes.

86.2 The average viscometric degree of polymerization is affected by heat to which the board may be exposed during manufacture, fabrication, or service.

86.3 Refer to Method D 4243 for further discussion of the significance of this method.

87. Procedure

87.1 Test in accordance with Method D 4243.

88. Report

88.1 The report shall be in accordance with Method D 4243 and Section 10 of these methods.

89. Precision and Bias

89.1 The precision and bias of this method are in accordance with Method D 4243.

90. Keywords

90.1 aqueous extract characteristics pH; ash content; compressibility; conditioning; conductivity; degree of polymerization; dielectric strength; dimensions; electrical insulating board density; impulse dielectric strength; moisture content; oil

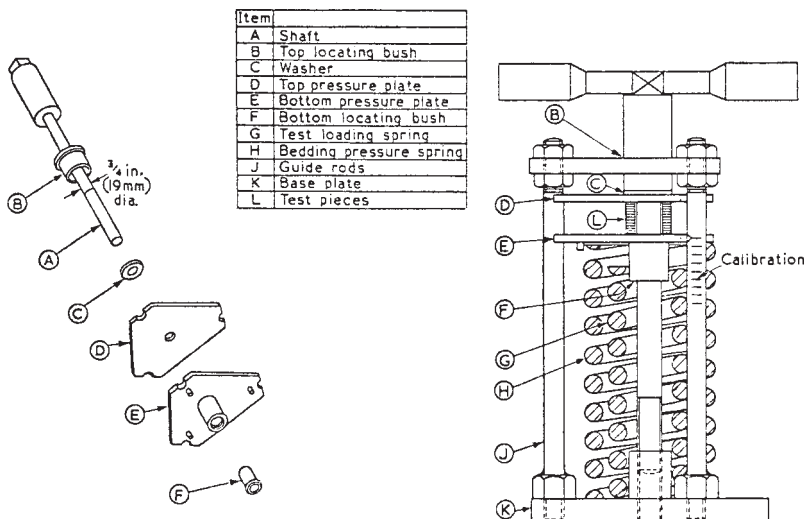

FIG. 1 Compression Test Apparatus

absorption; shrinkage; tensile properties

The American Society for Testing and Materials takes no position respecting the validity of any patent rights asserted in connection with any item mentioned in this standard. Users of this standard are expressly advised that determination of the validity of any such patent rights, and the risk of infringement of such rights, are entirely their own responsibility.

This standard is subject to revision at any time by the responsible technical committee and must be reviewed every five years and if not revised, either reapproved or withdrawn. Your comments are invited either for revision of this standard or for additional standards and should be addressed to ASTM Headquarters. Your comments will receive careful consideration at a meeting of the responsible technical committee, which you may attend. If you feel that your comments have not received a fair hearing you should make your views known to the ASTM Committee on Standards, at the address shown below.

This standard is copyrighted by ASTM, 100 Barr Harbor Drive, PO Box C700, West Conshohocken, PA 19428-2959, United States. Individual reprints (single or multiple copies) of this standard may be obtained by contacting ASTM at the above address or at 610-832-9585 (phone), 610-832-9555 (fax), or service@astm.org (e-mail); or through the ASTM website (www.astm.org).