



Standard Test Method for Compressive Properties of Polymer Matrix Composite Materials with Unsupported Gage Section by Shear Loading¹

This standard is issued under the fixed designation D 3410/D 3410M; the number immediately following the designation indicates the year of original adoption or, in the case of revision, the year of last revision. A number in parentheses indicates the year of last reapproval. A superscript epsilon (ϵ) indicates an editorial change since the last revision or reapproval.

This standard has been approved for use by agencies of the Department of Defense.

1. Scope

1.1 This test method determines the in-plane compressive properties of polymer matrix composite materials reinforced by high-modulus fibers. The composite material forms are limited to continuous-fiber or discontinuous-fiber reinforced composites for which the elastic properties are specially orthotropic with respect to the test direction. This test procedure introduces the compressive force into the specimen through shear at wedge grip interfaces. This type of force transfer differs from the procedure in Test Method D 695 where compressive force is transmitted into the specimen by end-loading, Test Method D 6641/D 6641M where compressive force is transmitted by combined shear and end loading, and Test Method D 5467/D 5467M where compressive force is transmitted by subjecting a honeycomb core sandwich beam with thin skins to four-point bending.

1.2 This test method is applicable to composites made from unidirectional tape, wet-tow placement, textile (for example, fabric), short fibers, or similar product forms. Some product forms may require deviations from the test method.

1.3 The values stated in either SI units or inch-pound units are to be regarded separately as standard. Within the text the inch-pounds units are shown in brackets. The values stated in each system are not exact equivalents; therefore, each system must be used independently of the other. Combining values from the two systems may result in nonconformance with the standard.

NOTE 1—Additional procedures for determining compressive properties of resin-matrix composites may be found in Test Methods D 695, D 5467/D 5467M, and D 6641/D 6641M.

1.4 *This standard does not purport to address all of the safety concerns, if any, associated with its use. It is the responsibility of the user of this standard to establish appro-*

priate safety and health practices and determine the applicability of regulatory limitations prior to use.

2. Referenced Documents

2.1 ASTM Standards:

- D 695 Test Method for Compressive Properties of Rigid Plastics²
- D 792 Test Methods for Density and Specific Gravity (Relative Density) of Plastics by Displacement²
- D 883 Terminology Relating to Plastics²
- D 2584 Test Method for Ignition Loss of Cured Reinforced Resins³
- D 2734 Test Methods for Void Content of Reinforced Plastics³
- D 3171 Test Method for Constituent Content of Composite Materials⁴
- D 3878 Terminology for Composite Materials⁴
- D 5229/D 5229M Test Method for Moisture Absorption Properties and Equilibrium Conditioning of Polymer Matrix Composite Materials⁴
- D 5379/D 5379M Test Method for Shear Properties of Composite Materials by the V-Notched Beam Method⁴
- D 5467/D 5467M Test Method for Compressive Properties of Unidirectional Polymer Matrix Composites Using a Sandwich Beam⁴
- D 6641/D 6641M Test Method for Determining the Compressive Properties of Polymer Matrix Composite Laminates Using a Combined Loading Compression (CLC) Test Fixture⁴
- E 4 Practices for Force Verification of Testing Machines⁵
- E 6 Terminology Relating to Methods of Mechanical Testing⁵
- E 83 Practice for Verification and Classification of Extensometers⁵
- E 111 Test Method for Young's Modulus, Tangent Modulus,

¹ This specification is under the jurisdiction of ASTM Committee D30 on Composite Materials and is the direct responsibility of Subcommittee D30.04 on Lamina and Laminate Test Methods.

Current edition approved June 10, 2003. Published August 2003. Originally approved in 1975. Last previous edition approved in 1995 as D 3410/D 3410M – 95.

² *Annual Book of ASTM Standards*, Vol 08.01.

³ *Annual Book of ASTM Standards*, Vol 08.02.

⁴ *Annual Book of ASTM Standards*, Vol 15.03.

⁵ *Annual Book of ASTM Standards*, Vol 03.01.

and Chord Modulus⁵

E 122 Practice for Calculating Sample Size to Estimate, With a Specified Tolerable Error, the Average for Characteristic of a Lot or Process⁶

E 132 Test Method for Poisson's Ratio at Room Temperature⁵

E 177 Practice for Use of the Terms Precision and Bias in ASTM Test Methods⁶

E 251 Test Methods for Performance Characteristics of Metallic Bonded Resistance Strain Gages⁵

E 456 Terminology Relating to Quality and Statistics⁶

E 1237 Guide for Installing Bonded Resistance Strain Gages⁵

E 1309 Guide for the Identification of Fiber-Reinforced Polymer-Matrix Composite Materials in Databases⁴

E 1434 Guide for Recording Mechanical Test Data of Fiber-Reinforced Composite Materials in Databases⁴

E 1471 Guide for the Identification of Fibers, Fillers, and Core Materials in Computerized Material Property Databases⁴

2.2 *ASTM Adjunct:*

Compression Fixture, D3410 Method B⁷

2.3 *Other Documents:*

ANSI Y14.5M-1982⁸

ANSI/ASME B46.1-1985⁸

3. Terminology

3.1 Terminology D 3878 defines terms relating to high-modulus fibers and their composites. Terminology D 883 defines terms relating to plastics. Terminology E 6 defines terms relating to mechanical testing. Terminology E 456 and Practice E 177 define terms relating to statistics. In the event of a conflict between terms, Terminology D 3878 shall have precedence over the other Terminology standards.

3.2 *Definitions of Terms Specific to This Standard:*

3.2.1 *nominal value, n*—a value, existing in name only, assigned to a measurable property for the purpose of convenient designation. Tolerances may be applied to a nominal value to define an acceptable range for the property.

3.2.2 *orthotropic material, n*—a material with a property of interest that, at a given point, possesses three mutually perpendicular planes of symmetry defining the principal material coordinate system for that property.

3.2.3 *principal material coordinate system, n*—a coordinate system with axes that are normal to the planes of symmetry that exist within the material.

3.2.4 *reference coordinate system, n*—a coordinate system for laminated composites used to define ply orientations. One of the reference coordinate system axes (normally the Cartesian *x*-axis) is designated the reference axis, assigned a position, and the ply principal axis of each ply in the laminate

is referenced relative to the reference axis to define the ply orientation for that ply.

3.2.5 *specially orthotropic, adj*—a description of an orthotropic material as viewed in its principal material coordinate system. In laminated composites, a specially orthotropic laminate is a balanced and symmetric laminate of the $[0_i/90_j]_{ns}$ family as viewed from the reference coordinate system, such that the membrane-bending coupling terms of the stress-strain relation are zero.

3.2.6 *transition strain, $e^{transition}$, n*—the strain value at the mid-range of the transition region between the two essentially linear portions of a bilinear stress-strain or strain-strain curve (a transverse strain-longitudinal strain curve as used for determining Poisson's ratio).

3.3 *Symbols:*

3.3.1 *A*—cross-sectional area of specimen.

3.3.2 *B_y*—percent bending in specimen.

3.3.3 *CV*—sample coefficient of variation, in percent.

3.3.4 *E*—modulus of elasticity in the test direction.

3.3.5 *F^{cu}*—ultimate compressive stress (compressive strength).

3.3.6 *G_{xz}*—through-thickness shear modulus of elasticity.

3.3.7 *h*—specimen thickness.

3.3.8 *i, j, n*—as used in a layup code, the number of repeats for a ply or group of plies of a material.

3.3.9 *l_g*—specimen gage length.

3.3.10 *n*—number of specimens.

3.3.11 *P*—force applied to test specimen.

3.3.12 *P^f*—force applied to test specimen at failure.

3.3.13 *P^{max}*—maximum force before failure.

3.3.14 *s*—as used in a layup code, denotes that the preceding ply description for the laminate is repeated symmetrically about its midplane.

3.3.15 *s_{n-1}*—sample standard deviation.

3.3.16 *w*—specimen width.

3.3.17 *x_i*—measured or derived property.

3.3.18 \bar{x} —sample mean (average).

3.3.19 $\bar{\epsilon}$ —indicated normal strain from strain transducer.

3.3.20 *v^c*—compressive Poisson's ratio.

3.3.21 σ_c —compressive normal stress.

4. Summary of Test Method

4.1 A flat strip of material having a constant rectangular cross section, as shown in the specimen drawings of Figs. 1-4, is loaded in compression by a shear force acting along the grips. The shear force is applied via wedge grips in a specially-designed fixture shown in Figs. 5-7. The influence of this wedge grip design on fixture characteristics is discussed in 6.1.

4.2 To obtain compression test results, the specimen is inserted into the test fixture which is placed between the platens of the testing machine and loaded in compression. The ultimate compressive stress of the material, as obtained with this test fixture and specimen, can be obtained from the maximum force carried before failure. Strain is monitored with strain or displacement transducers so the stress-strain response of the material can be determined, from which the ultimate

⁶ Annual Book of ASTM Standards, Vol 14.02.

⁷ A blueprint of the detailed drawing for the construction of the fixture shown in Fig. 4 is available at a nominal cost from ASTM International Headquarters, 100 Barr Harbor Dr., PO Box C700, West Conshohocken, PA 19428-2959. Order Adjunct ADJD3410.

⁸ Available from American National Standards Institute (ANSI), 25 W. 43rd St., 4th Floor, New York, NY 10036.

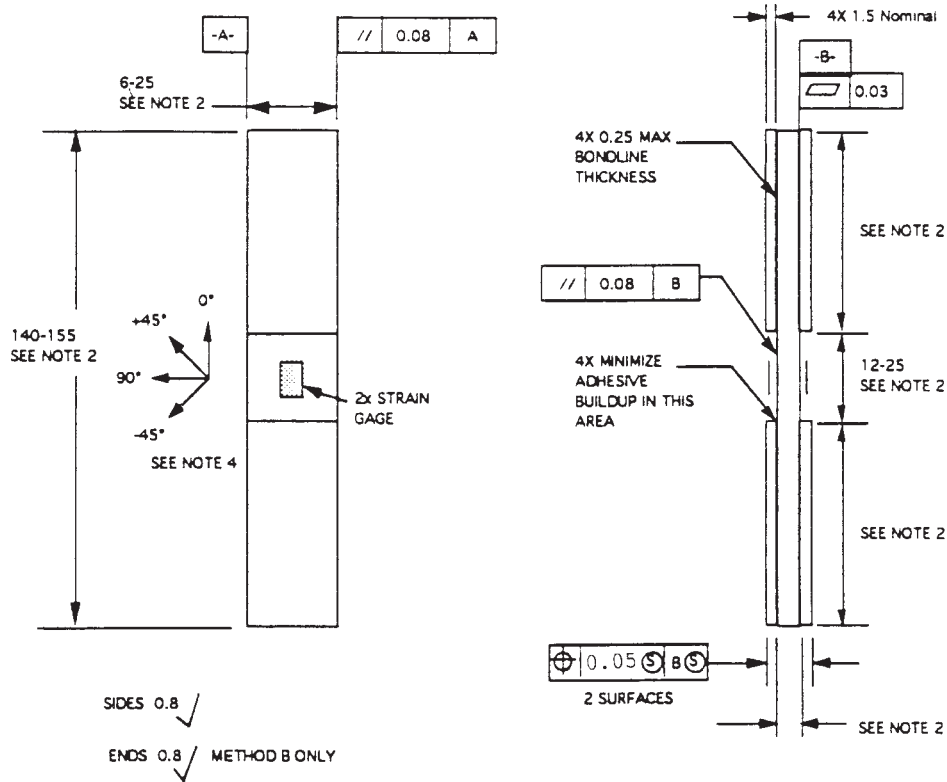

Notes:

1. Drawing interpretation per ANSI Y14.5M-1982 and ANSI/ASME B46.1-1985.
2. See Section 8 and Table 2 and Table 3 of the test standard for values of required or recommended width, thickness, gage length, tab length and overall length.
3. See test standard for values of material, ply orientation, use of tabs, tab material, tab angle, and tab adhesive.
4. Ply orientation tolerance relative to -A- $\pm 0.5^\circ$.

FIG. 1 Compression Test Specimen Drawing, (SI with Tabs)

compressive strain, the compressive modulus of elasticity, Poisson's ratio in compression, and transition strain can be derived.

5. Significance and Use

5.1 This test method is designed to produce compressive property data for material specifications, research and development, quality assurance, and structural design and analysis. Factors that influence the compressive response and should therefore be reported include the following: material, methods of material preparation and layup, specimen stacking sequence, specimen preparation, specimen conditioning, environment of testing, specimen alignment and gripping, speed of testing, time at temperature, void content, and volume percent reinforcement. Properties, in the test direction, that may be obtained from this test method include:

- 5.1.1 Ultimate compressive strength,
- 5.1.2 Ultimate compressive strain,
- 5.1.3 Compressive (linear or chord) modulus of elasticity,
- 5.1.4 Poisson's ratio in compression, and
- 5.1.5 Transition strain.

6. Interferences

6.1 *Test Fixture Characteristics*—This test method transmits force to the specimen via tapered rectangular wedge grips. The rectangular wedge grip design is used to eliminate the wedge seating problems induced by the conical wedges of the

so-called Celanese compression test fixture previously utilized in this test method (1).⁹ Earlier versions of this test method containing full details of the Celanese test method, including Test Method D 3410/D 3410M-95, are available.⁸ Another fixture characteristic that can have a significant effect on test results is the surface finish of the mating surfaces of the wedge grip assembly. Since these surfaces undergo sliding contact they must be polished, lubricated, and nick-free (11.5.1).

NOTE 2—An acceptable level of polish for the surface finish of wedge grip mating surfaces has been found to be one that ranges from 2 to 12 micro in. rms with a mean finish of 7 micro in. rms.

6.1.1 The specimen gripping faces of the wedge grips are typically roughened in some manner, as required for the particular application. Examples include serrated (7 to 8 serrations/cm) or thermal-sprayed tungsten carbide particle (100 grit) grip faces (see also 8.3.3).

6.2 *Test Method Sensitivity*—Compression strength for a single material system has been shown to differ when determined by different test methods. Such differences can be attributed to specimen alignment effects, specimen geometry effects, and fixture effects even though efforts have been made

⁹ Boldface numbers in parentheses refer to the list of references at the end of this test method.

Notes:

1. Drawing interpretation per ANSI Y14.5M-1982 and ANSI/ASME B46.1-1985
2. See Section 8 and Tables 2 and 3 of the test standard for values of required or recommended width, thickness, gage length, tab length and overall length.
3. See test standard for values of material, ply orientation, use of tabs, tab material, tab angle and tab adhesive.
4. Ply orientation tolerance relative to -A- $\pm 0.5^\circ$

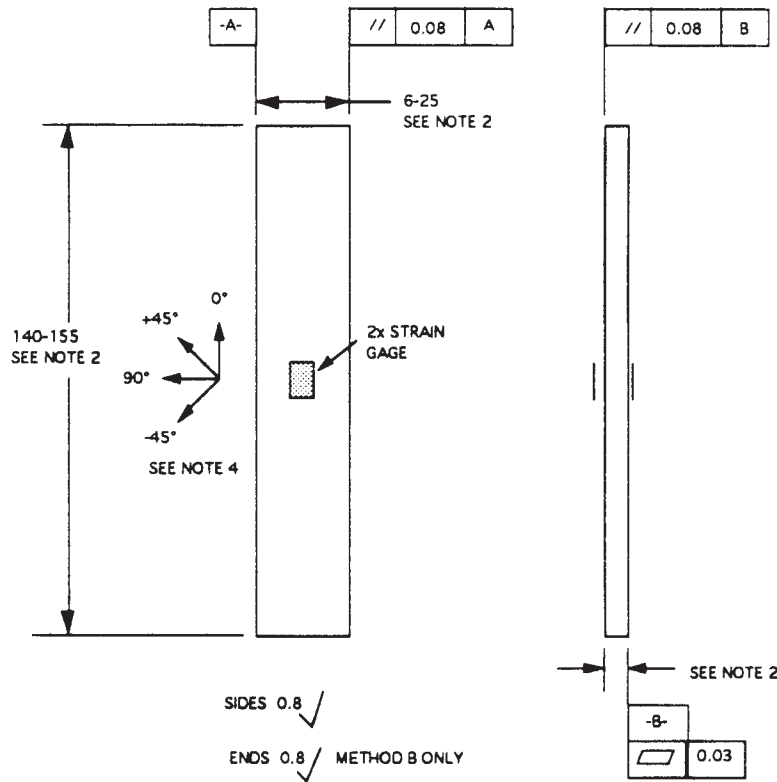

COMPRESSION TEST SPECIMEN WITHOUT TABS SI VERSION

All Dimensions in mm

FIG. 2 Compression Test Specimen Drawing, (SI without Tabs)

to minimize these effects. Examples of differences in test results between various test methods can be found in Refs (1,2).

6.3 *Material and Specimen Preparation*—Compression modulus, and especially ultimate compressive stress, are sensitive to poor material fabrication practices, damage induced by improper specimen machining, and lack of control of fiber alignment. Fiber alignment relative to the specimen coordinate axis should be maintained as carefully as possible, although no standard procedure to ensure this alignment exists. Procedures

found satisfactory include the following: fracturing a cured unidirectional laminate near one edge parallel to the fiber direction to establish the 0° direction, or laying in small filament count tows of contrasting color fiber (aramid in carbon laminates and carbon in aramid or glass laminates) parallel to the 0° direction either as part of the prepreg production or as part of panel fabrication.

6.4 *Tabbing and Tolerances*—The data resulting from this test method has been shown to be sensitive to the flatness and parallelism of the tabs, so care should be taken to ensure that

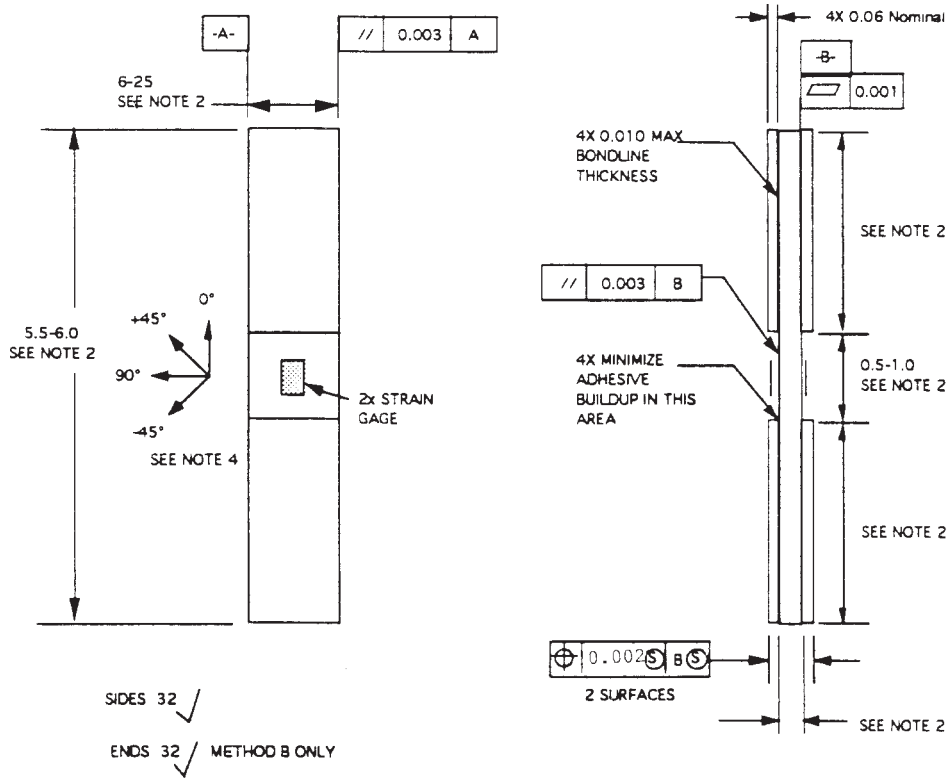

Notes:

1. Drawing interpretation per ANSI Y14.5M-1982 and ANSI/ASME B46.1-1985.
2. See Section 8 and Table 2 and Table 3 of the test standard for values of required or recommended width, thickness, gage length, tab length, and overall length.
3. See test standard for values of material, ply orientation, use of tabs, tab material, tab angle and tab adhesive.
4. Ply orientation tolerance relative to -A- $\pm 0.5^\circ$.

FIG. 3 Compression Test Specimen Drawing, (Inch-Pound with Tabs)

the specimen tolerance requirements are met. This usually requires precision grinding of the tab surfaces after bonding them to the specimen.

6.5 *Thickness and Gage Length Selection*—The gage section for this test method is unsupported, resulting in a tradeoff in the selection of specimen gage length and the specimen thickness. The gage length must be short enough to be free from Euler (column) buckling, yet long enough to allow stress decay to uniaxial compression and to minimize Poisson restraint effects as a result of the grips. Minimum thickness requirements are provided in 8.2.3.

6.6 *Gripping*—A high percentage of grip-induced failures, especially when combined with high material data scatter, is an indicator of specimen gripping problems.

6.7 *System Alignment*—Excessive bending will cause premature failure, as well as highly inaccurate modulus of elasticity determination. Every effort should be made to eliminate bending from the test system. Bending may occur for the following reasons: (1) misaligned (or out-of tolerance) grips or associated fixturing, (2) improper installation of specimen, or (3) poor specimen preparation.

6.8 *Edge Effects in Angle-Ply Laminates*—Premature failures and lower stiffnesses are observed due to edge softening in laminates containing off-axis plies. Because of this, the strength and modulus for angle-ply laminates can be underestimated. For quasi-isotropic laminates and those containing even higher percentages of 0° plies, the effect is less.

7. Apparatus

7.1 *Micrometers*—The micrometer(s) shall use a suitable size diameter ball interface on irregular surfaces such as the bag side of a laminate and a flat anvil interface on machined edges or very smooth tooled surfaces. The accuracy of the instruments shall be suitable for reading to within 1 % of the sample width and thickness. For typical specimen geometries, an instrument with an accuracy of $\pm 2.5 \mu\text{m}$ [$\pm 0.0001 \text{ in.}$] is desirable for thickness measurement, while an instrument with an accuracy of $\pm 25 \mu\text{m}$ [$\pm 0.001 \text{ in.}$] is desirable for width measurement.

7.2 *Compression Fixture:*

7.2.1 *Fixture*—The fixture uses rectangular wedges and allows for variable width and thickness specimens. A sectional schematic and photographs of the fixture are shown in Figs. 5-7. Each set of specimen wedge grips fits into a mating set of wedges that fits into the upper and lower wedge housing block assemblies. By using wedges of different thicknesses, specimens of varying thickness can be tested in this fixture. As indicated in Fig. 5, the wedge grips are sometimes provided with slots at the outer ends, to accommodate end bars. The ends of the specimen can be butted against these bars during grip screw tightening, to ensure that an equal length of specimen is gripped by each pair of wedge grips. These bars can be removed prior to the test, or remain in place to provide an

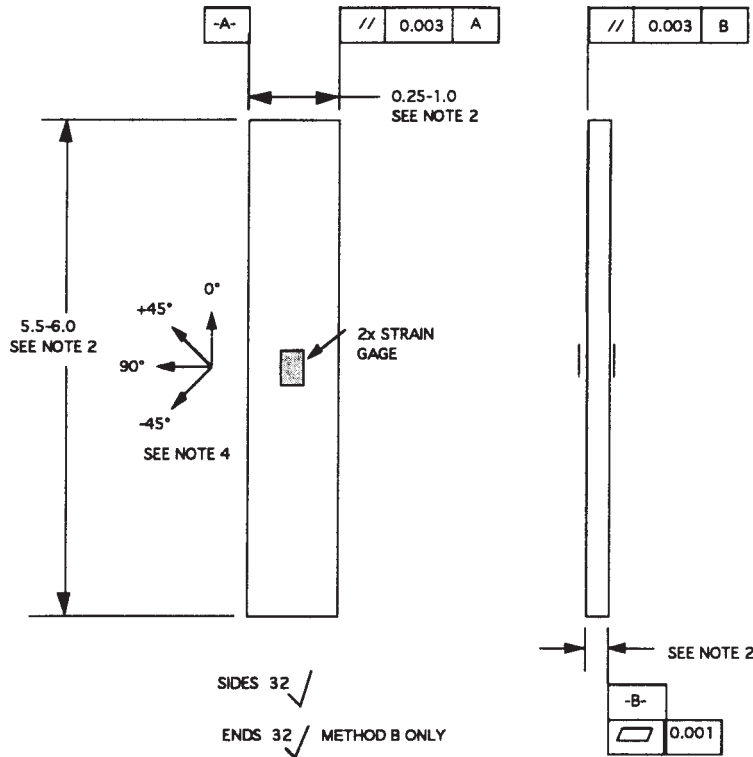

COMPRESSION TEST SPECIMEN WITH TABS
INCH-POUND VERSION
 All Dimensions in inches

- Notes:
1. Drawing interpretation per ANSI Y14.5M-1982 and ANSI/ASME B46.1-1985.
 2. See Section 8 and Table 2 and Table 3 of the test standard for values of required or recommended width, thickness, gage length, tab length, and overall length.
 3. See test standard for values of material, ply orientation, use of tabs, tab material, tab angle and tab adhesive.
 4. Ply orientation tolerance relative to -A- $\pm 0.5^\circ$.

FIG. 4 Compression Test Specimen Drawing, (Inch-Pound without Tabs)

(uncontrolled) degree of end-loading to the otherwise shear-loaded specimen. These bars also promote equal movement of each of the wedges of a pair during specimen loading, thus reducing induced specimen bending. Typically, the upper wedge housing block assembly is attached to the upper crosshead of the test machine while the lower wedge housing block assembly rests on a lower platen.

7.2.2 *Specimen Alignment Jig*—Compression test results generated by this test method are sensitive to the alignment of the specimen with respect to the longitudinal axis of the wedges in the test fixture. Specimen alignment can be accomplished by using an alignment jig or gage block that mechanically holds the specimen captive outside the fixture housing blocks (as shown in Fig. 8), or by using a custom jig or machinist’s square for a specimen inserted into wedge grips already in the fixture housing blocks. Alignment jigs and procedures other than those described are acceptable provided they perform the same function.

7.3 *Testing Machine*—The testing machine shall be in conformance with Practices E 4, and shall satisfy the following requirements:

7.3.1 *Testing Machine Heads*—The testing machine shall have two loading heads, with at least one movable along the testing axis.

7.3.2 *Fixture Attachment*—Typically the upper portion of the fixture is attached directly to the upper crosshead, and a flat platen attached to the lower crosshead is used to support the lower portion of the fixture. The platen should be at least 20 mm [0.75 in.] thick. The fixture may be coupled to the testing machine with a joint capable of eliminating angular restraint, such as a hemispherical ball on the machine that fits into a hemispherical recess.

NOTE 3—The use of a joint capable of eliminating angular restraint, such as a hemispherical ball, and the use of rigid, parallel crossheads should both be considered for this test method (3). To determine the most appropriate test configuration, a test fixture check-out procedure using untabbed aluminum specimens with back-to-back strain gages can be performed to determine the effect of attachment configuration on the accuracy and repeatability of test results.

7.3.3 *Drive Mechanism*—The testing machine drive mechanism shall be capable of imparting to the movable head a controlled displacement rate with respect to the stationary

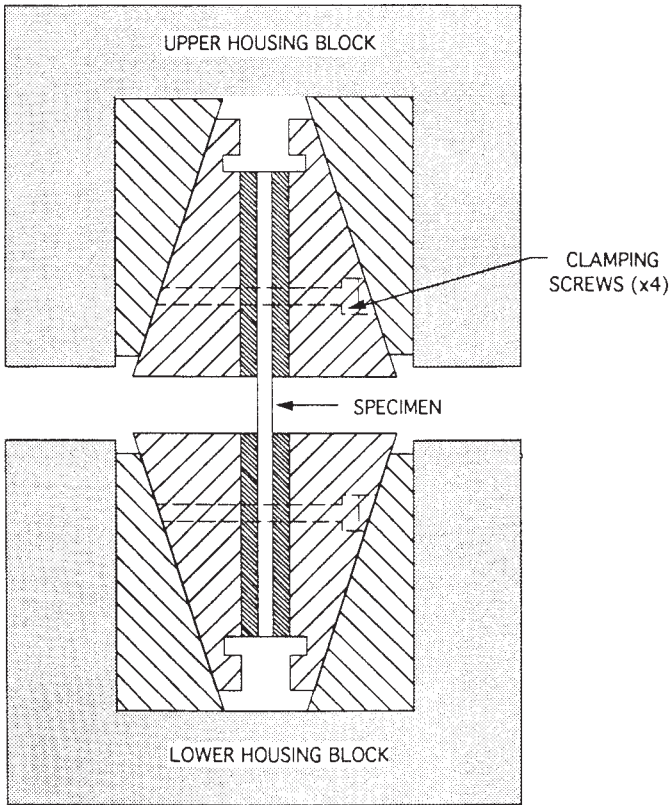

FIG. 5 Schematic of Compression Test Fixture

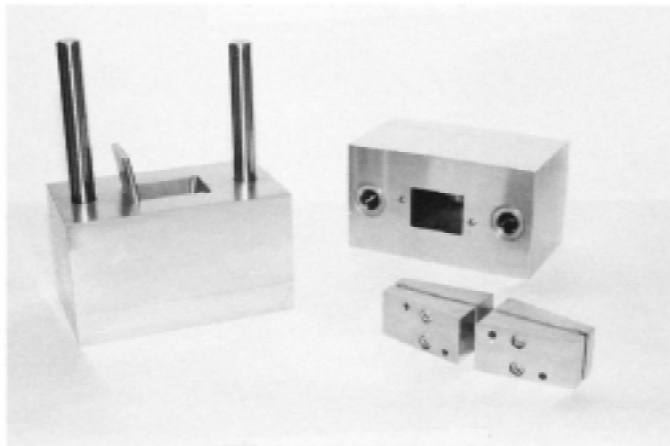

FIG. 6 Photograph of Compression Test Fixture

head. The displacement rate of the movable head shall be capable of being regulated as specified in 11.3.

7.3.4 Force Indicator—The testing machine force-sensing device shall be capable of indicating the total force being resisted by the test specimen. This device shall be essentially free from inertia-lag at the specified rate of testing and shall indicate the force with an accuracy over the force range(s) of interest of within $\pm 1\%$ of the indicated value, as specified by Practices E 4. The force range(s) of interest may be fairly low for modulus evaluation or much higher for strength evaluation, or both, as required.

NOTE 4—Obtaining precision force data over a large range of interest in

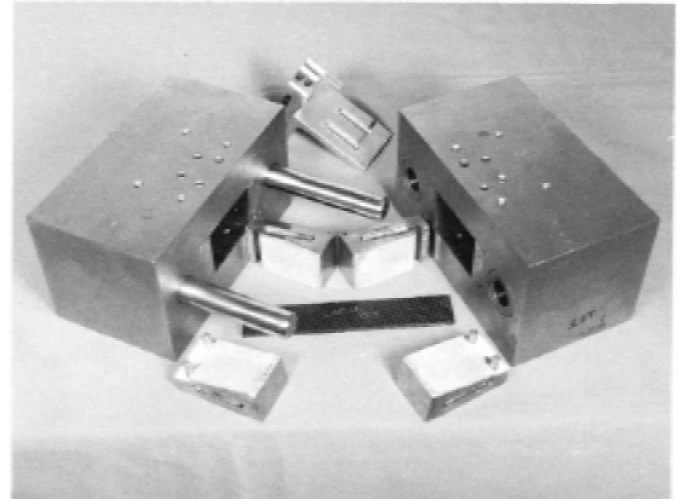
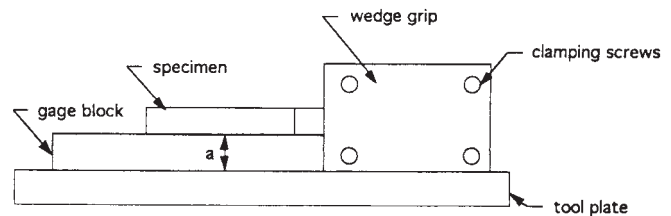
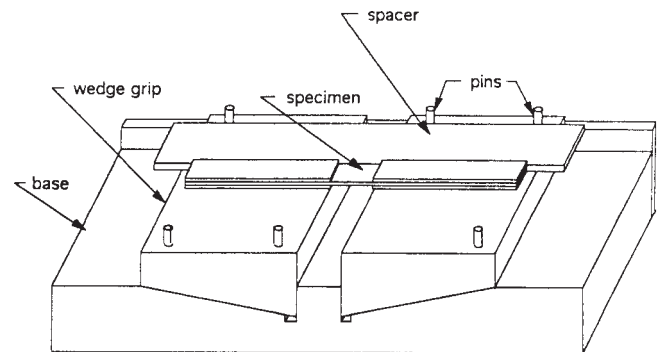

FIG. 7 Photograph of Compression Test Fixture



A gage block of appropriate height would be needed to center the specimen in the grips.

FIG. 8 Two Examples of Jigs for Specimen Alignment With Wedge Grips Outside the Fixture Housing Blocks (for Other Alignment Procedures see 7.2.2)

the same test, such as when both elastic modulus and ultimate force are being determined, place extreme requirements on the load cell and its calibration. For some equipment, a special calibration may be required. For some combinations of material and load cell, simultaneous precision measurement of both elastic modulus and ultimate compressive stress may not be possible, and measurement of modulus and ultimate compressive stress may have to be performed in separate tests using a different load cell range for each test.

7.4 Strain-Indicating Device—Longitudinal strain shall be simultaneously measured on opposite faces of the specimen to allow for a correction as a result of any bending of the

specimen and to enable detection of Euler (column) buckling. Back-to-back strain measurement shall be made for all five specimens when the minimum number of specimens allowed by this test method are tested. If more than five specimens are to be tested, then a single strain-indicating device may be used for the number of specimens greater than the five, provided the total number of specimens are tested in a single test fixture that remains in the load frame throughout the tests (see Note 5), that no modifications to the specimens or test procedure are made throughout the duration of the tests, and provided the bending requirement of 11.9.1 is met for the first five specimens. If these conditions are not met, then all specimens must be instrumented with back-to-back devices. When Poisson's ratio is to be determined, the specimen shall be instrumented to also measure strain in the lateral direction. Strain gages are recommended due to the short gage length of the specimen. Attachment of the strain-indicating device to the specimen shall not cause damage to the specimen surface.

NOTE 5—Portions of the test fixture may be removed from the loading frame as required in Section 11.

7.4.1 Bonded Resistance Strain Gages—Strain gage selection is a compromise based on the procedure and the type of material to be tested. Strain gages should have an active grid length of 3 mm [0.125 in.] or less (1.5 mm [0.063 in.] is preferable). Gage calibration certification shall comply with Test Methods E 251. When testing woven fabric laminates, gage selection should consider the use of an active gage length which is at least as great as the characteristic repeating unit of the weave. Some guidelines on the use of strain gages on composites are presented below with a general discussion on the subject in Refs (4,5).

7.4.1.1 Surface preparation of fiber-reinforced composites in accordance with Practice E 1237 can penetrate the matrix material and cause damage to the reinforcing fibers, resulting in improper specimen failures. Reinforcing fibers shall not be exposed or damaged during the surface preparation process. Consult the strain gage manufacturer regarding surface preparation guidelines and recommended bonding agents for composites.

7.4.1.2 Select gages having large resistances to reduce heating effects on low-conductivity materials. Resistances of 350 ohms or higher are preferred. Use the minimum possible gage excitation voltage consistent with the desired accuracy (1 to 2 V is recommended) to further reduce the power consumed by the gage. Heating of the specimen by the gage may affect the performance of the material directly, or it may affect the indicated strain due to a difference between the gage temperature compensation factor and the coefficient of thermal expansion of the specimen material.

7.4.1.3 Temperature compensation is recommended when testing at Standard Laboratory Atmosphere. Temperature compensation is required when testing in non-ambient temperature environments. When appropriate, use a traveler specimen (dummy calibration specimen) with identical layout and strain gage orientations for thermal strain compensation.

7.4.1.4 Consider the transverse sensitivity of the selected strain gage. Consult the strain gage manufacturer for recommendations on transverse sensitivity corrections. This is par-

ticularly important for a transversely mounted gage used to determine Poisson's ratio, as discussed in Note 15.

7.4.2 Extensometers—Extensometers shall satisfy, at a minimum, Practice E 83, Class B-2 requirements for the strain range of interest, and shall be calibrated over that strain range in accordance with Practice E 83. For extremely stiff materials, or for measurement of transverse strains, the fixed error allowed by Class B-2 extensometers may be too large. The extensometer shall be essentially free of inertia lag at the specified speed of testing.

7.5 Conditioning Chamber—When conditioning materials in other than ambient laboratory environments, a temperature-/moisture-level controlled environmental conditioning chamber is required that shall be capable of maintaining the required relative temperature to within $\pm 3^{\circ}\text{C}$ [$\pm 5^{\circ}\text{F}$] and the required relative vapor level to within $\pm 5\%$. Chamber conditions shall be monitored either on an automated continuous basis or on a manual basis at regular intervals.

7.6 Environmental Test Chamber—An environmental test chamber is required for test environments other than ambient testing laboratory conditions. This chamber shall be capable of maintaining the gage section of the test specimen within $\pm 3^{\circ}\text{C}$ [$\pm 5^{\circ}\text{F}$] of the required test temperature during the mechanical test. In addition, the chamber may have to be capable of maintaining environmental conditions such as fluid exposure or relative humidity during the test (see 11.4).

8. Sampling and Test Specimens

8.1 Sampling—Test at least five specimens per test condition unless valid results can be gained through the use of fewer specimens, such as in the case of a designed experiment. For statistically significant data, the procedures outlined in Practice E 122 should be consulted. The method of sampling shall be reported.

NOTE 6—If specimens are to undergo environmental conditioning to equilibrium, and are of such type or geometry that the weight change of the material cannot be properly measured by weighing the specimen itself (such as a tabbed mechanical specimen), then a traveler of the same nominal thickness and appropriate size (but without tabs) shall be used to determine when equilibrium has been reached for the specimens being conditioned.

8.2 Geometry—The test specimen shall have a constant rectangular cross section with a specimen width variation of no more than $\pm 1\%$ and a specimen thickness variation of no more than $\pm 2\%$. Specimen geometry requirements are listed in Table 1, and specimen geometry recommendations are listed in Table 2. Dimensionally-toleranced specimen drawings for both tabbed and untabbed forms are shown as examples in Figs. 1 and 2 (SI version) and Figs. 3 and 4 (inch-pound version). Both the specimen width and thickness shall contain a sufficient number of fibers or yarns to be statistically representative of the bulk material, or the material shall not be tested using this test method.

8.2.1 Specimen Width—The nominal specimen width shall be as recommended in Table 2.

8.2.2 Specimen Thickness—Specimen thickness, gage length, and width are related by Eq 1. The lower the expected modulus and the higher the expected ultimate compressive stress, the greater the specimen thickness must be in order to

**TABLE 1 Compression Specimen Geometry Requirements
(Unless Otherwise Noted)**

Parameter	Requirement
<i>Specimen Requirements:</i>	
shape	constant rectangular cross section
overall specimen length	as needed ^A
specimen gage length	as needed ^A
specimen width	as needed ^A
specimen thickness	see Table 3
specimen width tolerance	±1 % of width
specimen thickness tolerance	±2 % of thickness
<i>Tab Requirements (if used):</i>	
specimen thickness variation at tabbed ends	±1 % of thickness

^A See Table 2 for recommendations

prevent Euler (column) buckling in the test section. A conservative assumption of pinned-end conditions for column buckling was used in Eq 1 to compensate for beam-column effects produced by the bending moments induced by specimen and fixture tolerances. The requirement for the use of back-to-back strain measurements (7.4) provides the final assessment of specimen stability and quality of test results. Table 3 shows calculations for minimum specimen thickness as a function of expected modulus and ultimate compressive stress in the direction of force application for gage lengths of 12, 20, and 25 mm [0.5, 0.75, and 1.0 in.] using an assumed value of G_{xz} of 4 GPa [600 000 psi] (G_{xz} can be determined using Test Method D 5379/D 5379M).

$$h \geq \frac{l_g}{0.9069 \sqrt{\left(1 - \frac{1.2F^{cu}}{G_{xz}}\right) \left(\frac{E^c}{F^{cu}}\right)}} \quad (1)$$

where:

- E^c = longitudinal modulus of elasticity, MPa [psi],
- F^{cu} = ultimate compressive stress, MPa [psi],
- G_{xz} = through-thickness shear modulus, MPa [psi],
- h = specimen thickness, mm [in.], and
- l_g = length of gage section, 13 mm [0.50 in.].

NOTE 7—The conservative assumption of pinned-end conditions for column buckling in Eq 1 is based on linear elastic material response. The shear response of commonly used composites is highly nonlinear, and inelastic buckling calculations even for clamped-end conditions may not always yield higher buckling loads than for the elastic pinned-end condition. The use of back-to-back gages ensures that the thickness selected based on Eq 1 is sufficient to prevent column buckling. Back-to-back strain measurements will also indicate any secondary bending effects because of imperfections.

8.2.3 Overall Specimen Length and Gage Length—The overall specimen length and gage length shall be determined by the tab length and gage length chosen for the specimen. These requirements are listed in Table 1 and also shown in Figs. 1 and 2. The choice of specimen gage length is a trade-off between a length short enough to be free from Euler (column) buckling, yet long enough to both allow stress decay to uniform uniaxial compression and minimize Poisson restraint effects due to the grips (6,7). The distance required for admissible stress decay in a shear-loaded compression specimen has been shown to

increase with increasing specimen thickness and increasing E_x/G_{xz} ratio (6). For a typical carbon/epoxy specimen ($E_x = 138.6$ GPa [20.1 Msi], $G_{xz} = 4.6$ GPa [0.67 Msi], $h = 2.4$ mm [0.05 in.]), a uniform uniaxial compression stress state was achieved in 2.4 mm [0.094 in.]. This result shows a gage length of 12 mm [0.5 in.] is sufficient to allow stress decay for this material. Reference (4), also presents data suggesting admissible stress decay for a 12-mm [0.5-in.] gage length for both unidirectional boron- and glass-reinforced epoxy. For matrix materials that result in a composite with a high E_x/G_{xz} ratio (such as glass/PTFE, $E_x/G_{xz} = 406$) this gage length is not long enough to allow admissible stress decay. The insensitivity of the shear-loaded type of test specimen to gage length below the critical buckling length has also been shown experimentally in Ref (8). Recommended specimen gage length is 12 to 25 mm [0.5 to 1.0 in.] to balance the competing requirements of stress decay length and Euler buckling length. For gage lengths longer than 25 mm [1.0 in.], the required specimen thickness (8.2.3 and Table 3) may become unreasonable for typical fixturing. A tab length of 64 mm [2.5 in.] and resulting overall lengths of 140 to 155 mm [5.5 to 6.0 in.] are recommended.

8.3 Use of Tabs—Tabs are not required. The key factor in the selection of specimen tolerances and gripping methods is the successful introduction of force into the specimen and the prevention of premature failure due to a significant discontinuity. Therefore the need to use tabs, and specification of the major tab design parameters, shall be determined by the end result: acceptable failure mode and location. If acceptable failure modes occur with reasonable frequency (>50 % of the tests) then there is no reason to change a given gripping method (see 11.10).

8.3.1 Tabs bonded to the specimen are recommended when testing unidirectional materials in the fiber direction. However unidirectional [90]_n materials, [0_i/90_j]_{ns} or [90_i/0_j]_{ns} laminates (when $j \geq i$) and fabric-based materials can often be successfully tested without tabs.

8.3.2 Tab Geometry—The typical tab configuration is shown in Fig. 1 and Fig. 3. A tab bevel angle of 90° (untapered, as shown) is recommended. Tab thickness may vary, but is commonly 1.5 mm [0.06 in.]. The selection of a tab configuration that can successfully produce a gage section compression failure is dependent upon the specimen material, specimen ply orientation, and the type of grips being used. For alignment purposes, it is essential that the tabs be of matched thicknesses and the tab surfaces be parallel.

8.3.3 Friction Tabs—Tabs need not always be bonded to the material under test to be effective in introducing the force into the specimen. Friction tabs, essentially nonbonded tabs held in place by the pressure of the grip, and often used with emery cloth or some other light abrasive between the tab and the coupon, have been successfully employed in some applications. In specific cases, lightly serrated wedge grips have been successfully used with only emery cloth as the interface between the grip and the coupon. However, the abrasive used must be able to withstand significant compressive forces. Some

TABLE 2 Compression Specimen Geometry Recommendations

Fiber Orientation	Width, mm [in.]	Gage Length, mm [in.]	Tab Length, mm [in.]	Overall Length, mm [in.]	Tab Thickness, mm [in.]
0°, unidirectional	10 [0.5]	10–25 [0.5–1.0]	65 [2.5]	140–155 [5.5–6.0]	1.5 [0.06]
90°, unidirectional	25 [1.0]	10–25 [0.5–1.0]	65 [2.5]	140–155 [5.5–6.0]	1.5 [0.06]
Specially orthotropic	25 [1.0]	10–25 [0.5–1.0]	65 [2.5]	140–155 [5.5–6.0]	1.5 [0.06]

TABLE 3 Minimum Required Specimen Thickness (mm [in.])

Minimum Required Thickness (mm [in.]) for 10-mm [0.5-in.] Gage Length						
Longitudinal Modulus, GPa [Msi]	Expected Compression Strength, F^{cu} , MPa [ksi]					
	300 [50]	600 [100]	900 [150]	1200 [200]	1500 [250]	1800 [300]
25 [5]	1.27 [0.058]	1.89 [0.087]	2.45 [0.114]	3.02 [0.142]	3.64 [0.174]	4.36 [0.214]
50 [7]	1.00 [0.049]	1.33 [0.074]	1.73 [0.096]	2.14 [0.120]	2.58 [0.147]	3.08 [0.180]
75 [10]	1.00 [0.041]	1.09 [0.062]	1.41 [0.081]	1.74 [0.101]	2.10 [0.123]	2.52 [0.151]
100 [15]	1.00 [0.040]	1.00 [0.050]	1.22 [0.066]	1.51 [0.082]	1.82 [0.101]	2.18 [0.123]
200 [20]	1.00 [0.040]	1.00 [0.044]	1.00 [0.057]	1.07 [0.071]	1.29 [0.087]	1.54 [0.107]
300 [30]	1.00 [0.040]	1.00 [0.040]	1.00 [0.047]	1.00 [0.058]	1.05 [0.071]	1.26 [0.087]
400 [50]	1.00 [0.040]	1.00 [0.040]	1.00 [0.040]	1.00 [0.045]	1.00 [0.055]	1.09 [0.068]
500 [70]	1.00 [0.040]	1.00 [0.040]	1.00 [0.040]	1.00 [0.040]	1.00 [0.047]	1.00 [0.057]

Minimum Required Thickness (mm [in.]) for 20-mm [0.75-in.] Gage Length						
Longitudinal Modulus, GPa [Msi]	Expected Compression Strength, F^{cu} , MPa [ksi]					
	300 [50]	600 [100]	900 [150]	1200 [200]	1500 [250]	1800 [300]
25 [5]	2.53 [0.087]	3.77 [0.131]	4.90 [0.171]	6.04 [0.214]	7.28 [0.262]	8.72 [0.320]
50 [7]	1.79 [0.074]	2.67 [0.111]	3.46 [0.145]	4.27 [0.180]	5.15 [0.221]	6.17 [0.271]
75 [10]	1.46 [0.062]	2.18 [0.092]	2.83 [0.121]	3.49 [0.151]	4.21 [0.185]	5.04 [0.226]
100 [15]	1.27 [0.050]	1.89 [0.075]	2.45 [0.099]	3.02 [0.123]	3.64 [0.151]	4.36 [0.185]
200 [20]	1.00 [0.044]	1.33 [0.065]	1.73 [0.086]	2.14 [0.107]	2.58 [0.131]	3.08 [0.160]
300 [30]	1.00 [0.040]	1.09 [0.053]	1.41 [0.070]	1.74 [0.087]	2.10 [0.107]	2.52 [0.131]
400 [50]	1.00 [0.040]	1.00 [0.041]	1.22 [0.054]	1.51 [0.068]	1.82 [0.083]	2.18 [0.101]
500 [70]	1.00 [0.040]	1.00 [0.040]	1.10 [0.046]	1.35 [0.057]	1.63 [0.070]	1.95 [0.086]

Minimum Required Thickness (mm [in.]) for 25-mm [1.0-in.] Gage Length						
Longitudinal Modulus, GPa [Msi]	Expected Compression Strength, F^{cu} , MPa [ksi]					
	300 [50]	600 [100]	900 [150]	1200 [200]	1500 [250]	1800 [300]
25 [5]	3.17 [0.116]	4.72 [0.174]	6.12 [0.228]	7.55 [0.285]	9.10 [0.349]	10.91 [0.427]
50 [7]	2.24 [0.098]	3.33 [0.147]	4.33 [0.193]	5.34 [0.241]	6.44 [0.295]	7.71 [0.361]
75 [10]	1.83 [0.082]	2.72 [0.123]	3.53 [0.161]	4.36 [0.201]	5.26 [0.247]	6.30 [0.302]
100 [15]	1.58 [0.067]	2.36 [0.101]	3.06 [0.132]	3.77 [0.164]	4.55 [0.201]	5.45 [0.247]
200 [20]	1.12 [0.058]	1.67 [0.087]	2.16 [0.114]	2.67 [0.142]	3.22 [0.174]	3.86 [0.214]
300 [30]	1.00 [0.047]	1.36 [0.071]	1.77 [0.093]	2.18 [0.116]	2.63 [0.142]	3.15 [0.174]
400 [50]	1.00 [0.040]	1.18 [0.055]	1.53 [0.072]	1.89 [0.090]	2.28 [0.110]	2.73 [0.135]
500 [70]	1.00 [0.040]	1.05 [0.047]	1.37 [0.061]	1.69 [0.076]	2.04 [0.093]	2.44 [0.114]

types of emery cloth have been found ineffective in this application due to disintegration of the abrasive.¹⁰ An alternative is to use grip surfaces thermal-sprayed with tungsten carbide particles (9).

8.3.4 Tab Material—When tabs are used, the most commonly used materials are steel and continuous E-glass fiber-reinforced polymer matrix materials (woven or unwoven), in a [0/90]_{ns} laminate configuration. Tabs bonded to the specimen are recommended for unidirectional carbon fiber-reinforced composites that are to be tested in the fiber direction. Both steel and E-glass fabric tabs have been shown to produce satisfactory results for unidirectional carbon fiber-reinforced composites (10).

8.3.5 Adhesive Material—Any high-elongation (tough) adhesive system that meets the environmental requirements may

be used when bonding tabs to the material under test. A bondline of uniform thickness is required to minimize induced bending during the test.

8.4 Specimen Preparation:

8.4.1 Panel Fabrication—Control of fiber alignment is important. Improper fiber alignment will reduce the measured properties. Erratic fiber alignment will also increase the coefficient of variation. Suggested methods of maintaining fiber alignment are discussed in Section 6. The panel preparation method used shall be reported.

8.4.2 Machining Methods—Specimen preparation is extremely important. The specimens may be molded individually to avoid edge and cutting effects or they may be cut from panels. If they are cut from panels, precautions shall be taken to avoid notches, undercuts, rough or uneven surfaces, or delaminations caused by inappropriate machining methods. Final dimensions should be obtained by precision sawing, milling, or grinding. Mold or machine edges flat and parallel within the specified tolerances.

¹⁰ E-Z Flex Metalite K224 cloth, grit 120-J, or 120 grit D Burtie abrasive screen, both available from Norton Co., Troy, NY 12181, have been found satisfactory in this application. Other equivalent types of abrasive should be suitable.

8.4.3 *Labeling*—Label the specimens so that they will be distinct from each other and traceable back to the raw material, and in a manner that will both be unaffected by the test and not influence the test.

9. Calibration

9.1 The accuracy of all measuring equipment shall have certified calibrations that are current at the time of use of the equipment.

10. Conditioning

10.1 *Standard Conditioning Procedure*—Condition in accordance with Procedure C of Test Method D 5229/D 5229M; store and test at standard laboratory atmosphere ($23 \pm 3^\circ\text{C}$ [$73 \pm 5^\circ\text{F}$] and $50 \pm 10\%$ relative humidity) unless a different environment is specified as part of the experiment.

11. Procedure

11.1 *Parameters To Be Specified Before Test:*

11.1.1 The compression specimen sampling method, specimen type and geometry, and if required, conditioning travelers.

11.1.2 The compressive properties and data reporting format desired.

NOTE 8—Determine specific material property, accuracy, and data reporting requirements prior to test for proper selection of instrumentation and data recording equipment. Estimate operating stress and strain levels to aid in transducer selection, calibration of equipment, and determination of equipment settings.

11.1.3 The environmental conditioning test parameters.

11.1.4 If performed, the sampling method, specimen geometry, and test parameters used to determine density and reinforcement volume.

11.2 *General Instructions:*

11.2.1 Report any deviations from this test method, whether intentional or inadvertent.

11.2.2 If specific gravity, density, reinforcement volume, or void volume are to be reported, then obtain these samples from the same panels as the test samples. Specific gravity and density may be evaluated by means of Test Methods D 792. Volume percent of the constituents may be evaluated by one of the matrix digestion procedures of Test Methods D 3171, or, for certain reinforcement materials such as glass and ceramics, by the matrix burn-off technique of Test Method D 2584. Void content may be evaluated from the equations of Test Method D 2734 and are applicable to both Test Methods D 2584 and D 3171.

11.2.3 Condition the specimens, either before or after strain gaging, as required. Condition travelers if to be used.

NOTE 9—Gaging before conditioning may impede moisture absorption locally underneath the strain gage or the conditioning environment may degrade the strain gage adhesive, or both. On the other hand, gaging after conditioning may not be possible for other reasons, or the gaging activity itself may cause loss of conditioning equilibrium. When to gage specimens is left to the individual application and shall be reported.

11.2.4 Following final specimen machining and any conditioning, but before the compression testing, determine the specimen area as $A = w \times h$ at three places in the gage section

and report the area as the average of these three determinations to the accuracy in 7.1. Record the average area in units of mm^2 (in.^2).

11.2.5 Apply strain gages (or extensometers) to both faces of the specimen (see 7.4) as shown in Figs. 1-4.

11.3 *Loading Rate*—It is desired to maintain a constant strain rate in the gage section. If strain control is not available on the testing machine, this may be approximated by repeated monitoring and adjusting of the rate of force application to maintain a nearly constant strain rate, as measured by strain transducer response versus time. Select the strain rate so as to produce failure within 1 to 10 min from the beginning of force application. If the ultimate strain of the material cannot be reasonably estimated, conduct initial trials using standard crosshead speeds until the ultimate strain of the material and the compliance of the system are known, and the strain rate can be adjusted. The suggested standard rates are:

11.3.1 *Strain-Controlled Tests*—A standard strain rate of 0.01 min^{-1} .

11.3.2 *Constant Head-Speed Tests*—A standard crosshead displacement of 1.5 mm/min [0.05 in./min].

NOTE 10—Use of wedge grips can cause extreme compliance in the system, especially when using compliant tab materials. In some such cases, actual strain rates 10 to 50 times lower than estimated by crosshead speeds have been observed.

11.4 *Test Environment*—Condition the specimen to the desired moisture profile and, if possible, test under the same conditioning fluid exposure level. However, cases such as elevated temperature testing of a moist specimen place unrealistic requirements on the capabilities of common testing machine environmental chambers. In such cases testing at elevated temperature with no fluid exposure control may be necessary, and moisture loss during mechanical testing may occur. Reducing exposure time in the test chamber can minimize this loss, although care should be taken to ensure that the specimen temperature is at equilibrium. This loss may be further minimized by increasing the relative humidity in an uncontrolled chamber by hanging wet, coarse fabric inside the chamber, and keeping it moist with a drip bottle placed outside the chamber. In addition, fixtures may be preheated, temperature may be ramped up quickly, and hold time at temperature may be minimized before testing. Environmentally conditioned travelers may be used to measure moisture loss during exposure to the test environment. Weigh a traveler before testing and place it in the test chamber at the same time as the specimen. Remove the traveler immediately after fracture and reweigh it to determine moisture loss. Record modifications to the test environment.

11.4.1 Store the specimen in the conditioned environment until test time, if the testing area environment is different than the conditioning environment.

11.4.2 Monitor test temperature by placing an appropriate thermocouple within 25 mm [1.0 in.] of the specimen gage section. Maintain the temperature of the specimen, and the traveler, if one is being used for thermal strain compensation or moisture loss evaluation, within $\pm 3^\circ\text{C}$ [$\pm 5^\circ\text{F}$] of the required condition. Taping thermocouple(s) to the test specimen (and the traveler) is an effective measurement method.

11.5 Fixture Installation:

NOTE 11—The following procedure is intended for vertical testing machines.

11.5.1 Ensure that the sliding surfaces of the fixture wedges, guide rods, and bearings are flat (wedges), polished, lubricated, and nick- and corrosion-free.

11.5.2 Inspect the parallelism of the platens and the condition of the mating surfaces of the wedge housing blocks. Correct if needed.

11.5.3 Place the lower wedge housing block on the lower platen. Attach the upper wedge housing block to the upper crosshead or insert it into the upper wedge housing holding fixture, centered over the lower wedge housing block. While the load cell may be connected to either crosshead as required, the entire assembly must be centered on the line of action of applied force.

11.5.4 Move a crosshead to close the distance between the two housing blocks while guiding the bearing guide rods into the mating bearing of the companion housing block. The lower housing block can be fitted with guide rods long enough to allow the rods to remain in the bearings while the wedge/specimen assembly is loading into and out of the housing blocks.

11.6 Specimen/Insertion:

11.6.1 If necessary, move the testing machine crosshead to open the distance between the two housing blocks so that both upper and lower wedge grip assemblies may be accessed.

11.6.2 If specimen alignment is to be performed with the grip/specimen assembly outside the fixture housing blocks (see 7.2.2), perform this procedure. Place the completed grip/specimen assembly into the lower housing block and close the distance between the housing blocks as described in 11.6.6.

NOTE 12—The ends of the wedge grips should be even with each other following insertion into the housing blocks to avoid inducing a bending moment that results in premature failure of the specimen at the grips. When using an untabbed specimen, a folded strip of medium-grade abrasive cloth between the specimen faces and the grip jaws (grit side toward specimen) may provide a non-slip grip on the specimen without jaw serration damage to the surface of the specimen. When using tabbed specimens, insert the specimen so that the grip jaws grip the entire length of the tab.

11.6.3 If the specimen is to be aligned with the wedge grips in the fixture housing blocks, raise the lower jaws within the lower housing assembly so that grip-faces open to allow specimen insertion. Place the specimen between the grips such that the entire grip length will contact the grip faces when closed. Center the specimen from side to side (see 7.2.2) and then lower the grips, lightly clamping the specimen. Arrange any pre-attached transducer lead-wires as required.

11.6.4 If necessary, free the upper wedge grips so that they are in the fully open position. Moving the crosshead, close the distance between the housing blocks and guide the upper end of the specimen into the opening between the upper wedge grips. Stop the head and zero the force on the testing machine.

11.6.5 Manually close the upper grips to check specimen vertical displacement. As with the lower grips, when the upper grips are closed onto the specimen the entire grip length should be in contact with the wedge grip faces. If necessary, adjust the head position and repeat 11.6.5.

11.6.6 Keeping the grips closed onto the specimen, slowly close the distance between the housing blocks by moving the crosshead while watching the force indicator. Stop the crosshead when the specimen begins to take a compressive force. The application of a small amount of initial compressive force, followed by immediate removal, may be helpful in seating the fixture grips before the test. This preload should be kept to a minimum, in no case more than 5 % of the ultimate force for the material, and use of the technique shall be recorded in the test results.

11.7 *Transducer Installation*—If the strain transducer(s) other than strain gages are to be used, attach them to the specimen at the mid-span, mid-width location. Attach the strain recording instrumentation to the strain gages or other transducer(s) on the specimen. Remove any remaining preload and zero the transducer(s).

11.8 *Loading*—Apply the force to the fixture at the specified rate until failure while recording data.

11.9 *Data Recording*—Record force versus strain (or displacement) continuously or at frequent regular intervals. If a transition region or initial ply failures are noted, record the force, strain, and mode of damage at such points. If the specimen is to be failed, record the maximum force, the failure force, and the strain (or transducer displacement) at, or as near as possible to, the moment of failure.

NOTE 13—Other valuable data that can be useful in understanding testing anomalies and gripping or specimen slipping problems include force versus crosshead displacement data and force versus time data.

11.9.1 A difference in the stress-strain or force-strain slope from opposite faces of the specimen indicates bending in the specimen. For the elastic property test results to be considered valid, percent bending in the specimen shall be less than 10 % as determined by Eq 2. Determine percent bending at the midpoint of the strain range used for chord modulus calculations (Table 4). The same requirement shall be met at failure strain for the strength and strain-to-failure data to be considered valid. This requirement shall be met for all five of the specimens requiring back-to-back strain measurement. If possible, a plot of percent bending versus average strain should be recorded to aid in the determination of failure mode.

TABLE 4 Specimen Alignment and Chord Modulus Calculation Strain Ranges

Longitudinal Strain Range for Chord Modulus Calculation		Longitudinal Strain Checkpoint for Bending, $\mu\epsilon$
Start Point, $\mu\epsilon$	End Point, $\mu\epsilon$	
1000 ^A	3000	2000

^A This strain range was specified to represent the lower half of the stress/strain curve. For materials that fail below 6000 $\mu\epsilon$, a strain range of 25 to 50 % of ultimate is recommended.

$$B_y = \text{Percent Bending} = \frac{\epsilon_1 - \epsilon_2}{\epsilon_1 + \epsilon_2} \times 100 \quad (2)$$

where:

- B_y = percent bending in specimen,
- ϵ_1 = indicated strain from Gage 1,
- ϵ_2 = indicated strain from Gage 2, and
- ϵ_{ave} = average longitudinal strain $(\epsilon_1 + \epsilon_2)/2$ at the data point closest to the strain checkpoint for bending.

11.9.2 Rapid divergence of the strain readings on the opposite faces of the specimen, or rapid increase in percent bending, is indicative of the onset of Euler (column) buckling, which is not an acceptable compression failure mode for this test method. Record any indication of Euler buckling.

11.10 *Failure Identification Codes*—Record the mode, area, and location of failure for each specimen. Choose a standard failure identification code based on the three-part code shown in Fig. 9. A multimode failure can be described by including

each of the appropriate failure-mode codes between the parentheses of the M failure mode. For example, a typical gage-section compression failure for a $[90/0]_{ns}$ laminate having elements of **A**ngled, **K**ink-banding, and longitudinal **S**plitting in the middle of the gage section would have a failure mode code of M(AKS)GM. Examples of overall visual specimen failures and associated Failure Identification Codes (four acceptable and four unacceptable) are shown in Fig. 9.

11.10.1 *Acceptable Failure Modes*—The first character of the Failure Identification Code describes the failure mode. All of the failure modes in the “First Character” Table of Fig. 9 are acceptable with the exception of end-crushing or Euler buckling. An Euler buckling failure mode cannot be determined by visual inspection of the specimen during or after the test, therefore it must be determined through inspection of the stress-strain or force-strain curves when back-to-back strain indicating devices are used (see 7.4).

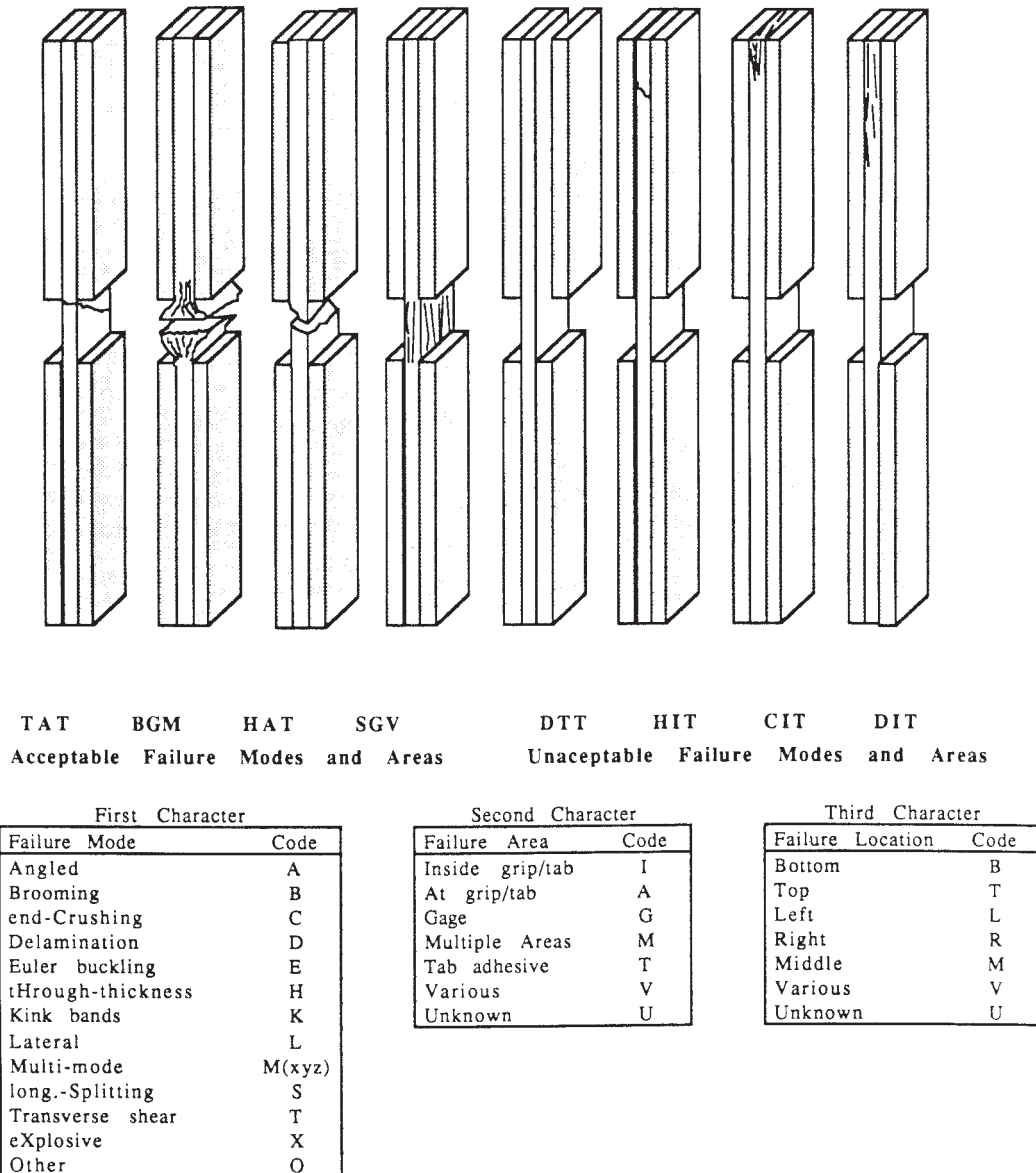

FIG. 9 Compression Test Specimen Three-Part Failure Identification Codes and Overall Specimen Failure Schematics

11.10.2 *Acceptable Failure Area*—The most desirable failure area is the middle of the gage section since the gripping/tapping influence is minimal in this region. Because of the short gage length of the specimens in this test method, it is very likely that the failure location will be near the grip/tab termination region of the gage section. Although not as desirable as the middle of the gage section, this is an acceptable failure area. If a significant fraction (>50 %) of the failures in a sample population occurs at the grip or tab interface, reexamine the means of force introduction into the specimen. Factors considered should include the tab alignment, tab material, tab adhesive, grip type, grip pressure, and grip alignment. Any failure that occurs inside the grip/tab portion of the specimen is unacceptable.

12. Calculation

12.1 *Compressive Stress/Ultimate Compressive Stress*—Calculate the ultimate compression strength using Eq 3 and report the results to three significant figures. If the compressive modulus is to be calculated, determine the compressive stress at each required data point using Eq 4.

$$F^{cu} = P^{max}/A \quad (3)$$

$$\sigma_i^c = P_i/A \quad (4)$$

where:

- F^{cu} = compressive strength, MPa [psi],
- P^{max} = maximum force before failure, N [lbf],
- P_i = force at i th data point, N [lbf],
- A = cross-sectional area at test section, mm²[in.²], and
- σ_i^c = compressive stress as the i th data point, MPa [psi].

12.2 *Compressive Strain and Ultimate Compression Strain*—If compressive modulus or ultimate compressive strain is to be calculated, determine the average compressive strain at each required data point using Eq 5 and 6, respectively, and report the results to three significant figures.

$$\epsilon_i^c = \frac{\epsilon_{1i} + \epsilon_{2i}}{2} \quad (5)$$

$$\epsilon^{cu} = \frac{\epsilon_1^{cu} + \epsilon_2^{cu}}{2} \quad (6)$$

where:

- ϵ_i^c = average compressive strain at i th data point, $\mu\epsilon$,
- ϵ_{1i} = gage-1 compressive strain at i th data point, $\mu\epsilon$,
- ϵ_{2i} = gage-2 compressive strain at i th data point, $\mu\epsilon$,
- ϵ^{cu} = average ultimate compressive strain, $\mu\epsilon$.
- ϵ_1^{cu} = gage-1 ultimate compressive strain, $\mu\epsilon$, and
- ϵ_2^{cu} = gage-2 ultimate compressive strain, $\mu\epsilon$.

12.3 Compressive Modulus of Elasticity:

12.3.1 *Compressive Chord Modulus of Elasticity*—Select the appropriate chord modulus strain range from Table 4. Calculate the compressive chord modulus of elasticity from the stress-strain data using Eq 7. If data are not available at the exact strain range end points (as often occurs with digital data), use the closest available data point. Report the compressive

chord modulus of elasticity to three significant figures. Also report the strain range used in the calculation. A graphical example of chord modulus is shown in Fig. 10.

12.3.1.1 The recommended strain ranges should only be used for materials that do not exhibit a transition region (a significant change in the slope of the stress-strain curve) within the recommended strain range. If a transition region occurs within the recommended strain range, then a more suitable strain range should be used and reported.

$$E^{chord} = \Delta\sigma/\Delta\epsilon \quad (7)$$

where:

- E^{chord} = chord modulus of elasticity, MPa [psi],
- $\Delta\sigma$ = difference in applied compressive stress between the two strain points of Table 4, MPa [psi], and
- $\Delta\epsilon$ = difference in the average compressive strain between the two strain points of Table 4 (use absolute strain, not microstrain, nominally 0.002).

12.3.2 *Compressive Modulus of Elasticity (Other Definitions)*—Other definitions of elastic modulus may be evaluated and reported at the user's discretion. If such data are generated and reported, report also the definitions used, the strain range used, and the results to three significant figures. Test Method E 111 provides additional guidance in the determination of Modulus of Elasticity.

NOTE 14—An example of another modulus definition is the secondary chord modulus of elasticity for materials that exhibit essentially bilinear stress-strain behavior. An example of secondary chord modulus is shown in Fig. 10.

12.4 Compressive Poisson's Ratio:

NOTE 15—If bonded resistance strain gages are being used, the error produced by the transverse sensitivity effect on the transverse gage will generally be much larger for composites than for metals. An accurate measurement of Poisson's ratio requires correction for this effect. Contact the strain gage manufacturer for information on the use of correction factors for transverse sensitivity.

12.4.1 *Compressive Poisson's Ratio By Chord Method*—Select the appropriate Poisson's ratio strain range from Table 4. Determine (by plotting or otherwise) the transverse strain (strain in the plane of the specimen and perpendicular to the applied force), ϵ_t , at each of the two longitudinal strain range endpoints (measured parallel to the applied force), ϵ_l . If data are not available at the exact strain range endpoints (as often occurs with digital data), use the closest available data point. Calculate Poisson's ratio in the appropriate strain range by Eq 8 and report to three significant figures.

12.4.1.1 When determining Poisson's ratio, match the transverse strain with the appropriate longitudinal strain. For instance, match output from a single transverse strain gage with the output from the single longitudinal gage mounted in an adjacent location on the same side of the specimen. If back-to-back transverse gages are used, average their output and compare to the average longitudinal strain.

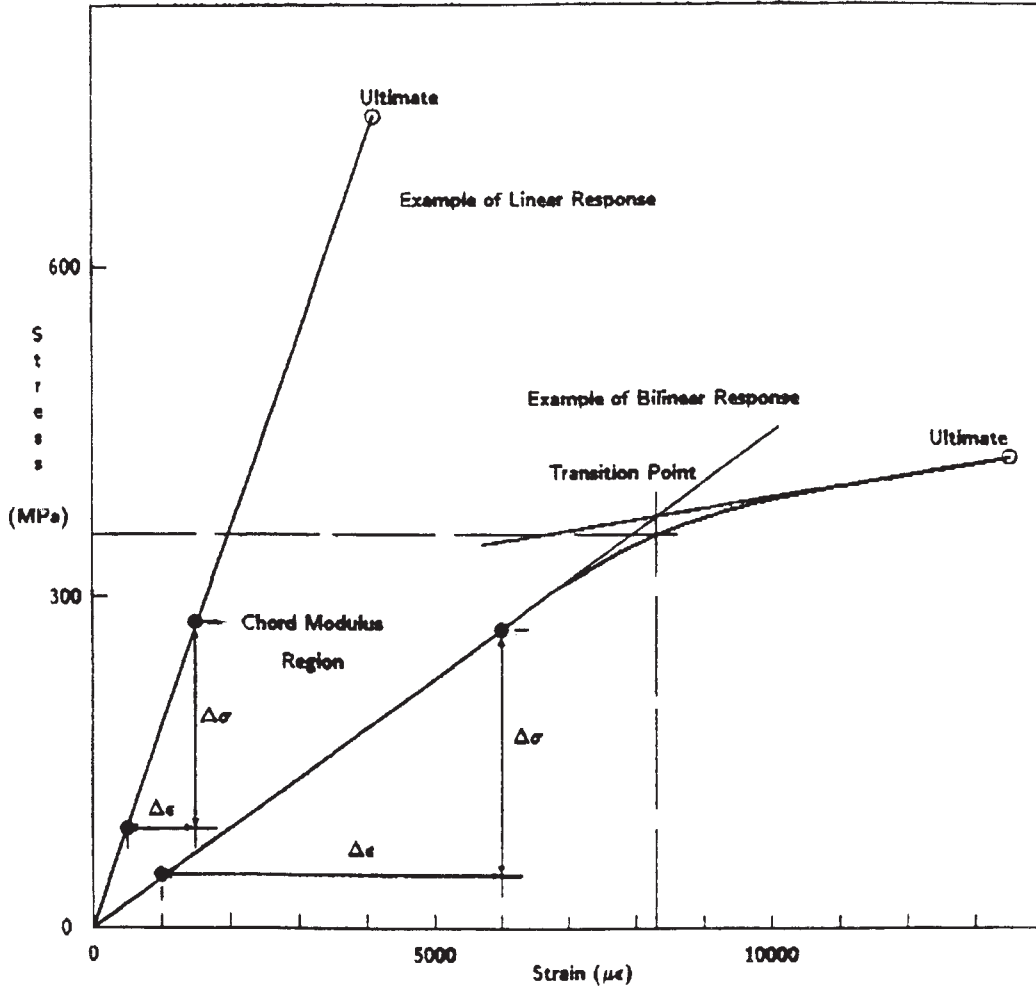

FIG. 10 Typical Compression Stress-Strain Curves

$$\nu^c = \Delta\epsilon_t / \Delta\epsilon_l \quad (8)$$

where:

ν^c = Poisson's ratio,

$\Delta\epsilon_t$ = difference in transverse strain occurring between the two longitudinal strain points, and

$\Delta\epsilon_l$ = difference in longitudinal compressive strain occurring between the two strain points of Table 4 (use absolute strain, not microstrain, nominally either 0.001, 0.002, or 0.005).

12.4.2 *Compressive Poisson's Ratio (Other Definitions)*—Other definitions of Poisson's ratio may be evaluated and reported at the user's discretion. If such data are generated and reported, report also the definitions used, the strain range used, and the results to three significant figures. Test Method E 132 provides additional guidance in the determination of Poisson's ratio.

12.5 *Transition Strain*—Where applicable, determine the transition strain from either the bilinear longitudinal stress versus longitudinal strain curve or the bilinear transverse strain versus longitudinal strain curve. Create a best linear fit or chord line for each of the two linear regions and extend the lines until

they intersect. Determine to three significant figures the longitudinal strain that corresponds to the intersection point and record this value as the transition strain. Report also the method of linear fit (if used) and the strain ranges over which the linear fit or chord lines were determined. A graphical example of transition strain is shown in Fig. 10.

12.6 *Statistics*—For each series of tests calculate the average value, standard deviation and coefficient of variation (in percent) for each property determined.

$$\bar{x} = \frac{1}{n} \left(\sum_{i=1}^n x_i \right) \quad (9)$$

$$s_{n-1} = \sqrt{\frac{\left(\sum_{i=1}^n (x_i - \bar{x})^2 \right)}{(n-1)}} \quad (10)$$

$$CV = 100 \times s_{n-1} / \bar{x} \quad (11)$$

where:

\bar{x} = sample mean (average),

s_{n-1} = sample standard deviation,

CV = sample coefficient of variation, in %,

n = number of specimens, and
 x_i = measured or derived property.

13. Report

13.1 The information reported for this test method includes material identification and mechanical testing data. These data shall be reported in accordance with Guides E 1309 and E 1471. Each data item discussed is identified as belonging to one of the following categories: (ET) Essential for Test validity, (RT) Recommended for Test validity, (EM) Essential for Material traceability, or (O) Optional. The following information applies to the use of these documents for reporting data:

13.1.1 *Guide E 1309 Identification of Composite Materials in Computerized Material Property Databases:*

13.1.1.1 The consolidation method should be reported as the process stage type in Field F8.

13.1.1.2 The nominal cure cycle is essential for valid material traceability in one set of process stage conditions in Fields F9-F18. The actual cure cycle is recommended in a second set of process stage conditions in Fields F9-F18.

13.1.2 *Guide E 1434 Development of Standard Data Records for Computerization of Mechanical Test Data for High-Modulus Fiber-Reinforced Composite Materials:*

13.1.2.1 The response for Field H6, Type of Test, is “Compression.”

13.1.2.2 Measured values will be reported for Fields M4 and M6. Nominal values are acceptable for Fields M7-M9.

13.1.2.3 The failure identification code will be reported in Fields P15 and R64. The failure location is optional in Fields P14 and R63 since the failure identification code includes this information.

13.1.2.4 “Transition strain” is the progress damage parameter recorded in Fields P58 and R60. Values of the transition strain are considered essential for test validity in Fields P59, R61, and R62.

13.1.2.5 Statistical parameters for specimen dimensions and bending strain are optional. These include Fields R1-R9 and R33. The testing summary sub-block is also optional (Fields R14-R18).

14. Precision and Bias

14.1 *Precision*—The precision, defined as the degree of mutual agreement between individual measurements, cannot yet be estimated because of an insufficient amount of data. Round-robin data are available in ASTM STP 808(2).

14.2 *Bias*—Bias cannot be determined for this test method as no acceptable reference standard exists.

15. Keywords

15.1 composite materials; compressive modulus of elasticity; compressive properties; compressive strength; Poisson’s ratio

REFERENCES

- (1) Hofer, K. E., and Rao, P. N., “A New Static Compression Fixture for Advanced Composite Materials,” *Journal of Testing and Evaluation*, 1977, 5(4).
- (2) Adsit, N. R., “Compression Testing of Graphite/Epoxy,” *Compression Testing of Homogeneous Materials and Composites*, ASTM STP 808, Chait and Papirno, Ed., ASTM, 1983, pp. 175–186.
- (3) Wegner, P. M., and Adams, D. F., “Verification of the Combined Loading Compression Test Method,” *Final Report No. DOT/FAA/AR-00/26*, Federal Aviation Administration Technical Center, Atlantic City, NJ, August 2000.
- (4) Pendleton, R. P., and Tuttle, M. E., *Manual on Experimental Methods for Mechanical Testing of Composites*. 1989, Bethel, CT; Society for Experimental Mechanics.
- (5) Masters, J. E. and Ifju, P. G., “Strain Gage Selection Criteria for Textile Composite Materials,” *Journal of Composites Technology & Research*, Vol 19, No. 3, 100, pp. 152-167.
- (6) Bogetti, T. A., Gillespie, J. W. J., and Pipes, R. B., “Evaluation of the IITRI Compression Test Method for Stiffness and Strength Determination,” *Composites Science and Technology*, 1989, 32(1):pp. 57–76.
- (7) Tan, S. C., “Stress Analysis and the Testing of Celanese and IITRI Compression Specimens,” *Composites Science and Technology*, Vol 44, 1992, pp. 57-70.
- (8) Adams, D. F., and Lewis, E. Q., “Influence of Specimen Gage Length and Loading Method on the Axial Compression Strength of a Unidirectional Composite Material,” *Experimental Mechanics*, 1991, 31(1):pp. 14–20.
- (9) Coguill, R. J., and Adams, D. F., “Selection of the Proper Wedge Grip Surface for Tensile Testing Composite Materials,” *Proceedings of the 44th International SAMPE Symposium*, Long Beach California, May 1999, pp. 2332-2345.
- (10) Adams, D. F., and Odom, E. M., “Influence of Specimen Tabs on the Compressive Strength of a Unidirectional Composite Material,” *Journal of Composite Materials*, 1990, 25(6):pp.774–786.

ASTM International takes no position respecting the validity of any patent rights asserted in connection with any item mentioned in this standard. Users of this standard are expressly advised that determination of the validity of any such patent rights, and the risk of infringement of such rights, are entirely their own responsibility.

This standard is subject to revision at any time by the responsible technical committee and must be reviewed every five years and if not revised, either reapproved or withdrawn. Your comments are invited either for revision of this standard or for additional standards and should be addressed to ASTM International Headquarters. Your comments will receive careful consideration at a meeting of the responsible technical committee, which you may attend. If you feel that your comments have not received a fair hearing you should make your views known to the ASTM Committee on Standards, at the address shown below.

This standard is copyrighted by ASTM International, 100 Barr Harbor Drive, PO Box C700, West Conshohocken, PA 19428-2959, United States. Individual reprints (single or multiple copies) of this standard may be obtained by contacting ASTM at the above address or at 610-832-9585 (phone), 610-832-9555 (fax), or service@astm.org (e-mail); or through the ASTM website (www.astm.org).