



Standard Test Method for Ignition Temperature of Granular Activated Carbon¹

This standard is issued under the fixed designation D 3466; the number immediately following the designation indicates the year of original adoption or, in the case of revision, the year of last revision. A number in parentheses indicates the year of last reapproval. A superscript epsilon (ϵ) indicates an editorial change since the last revision or reapproval.

1. Scope

1.1 This test method covers the determination of reference ignition temperature of granular activated carbon in flowing air. This test method provides a basis for comparing the ignition characteristics of different carbons, or the change in ignition characteristics of the same carbon after a period of service.

1.2 The ignition temperature as determined by this test method cannot be interpreted as the probable ignition temperature of the same carbon under the operating conditions of a specific application unless those conditions are essentially the same as those in this test method. If it is desired to determine the ignition temperature of the carbon under a specific set of operating conditions, the test may be modified to simulate such conditions, taking into consideration the following variables: (1) air flow rate; (2) moisture content of the carbon; (3) bed depth; (4) relative humidity of the air stream; (5) heating rate; (6) contaminants (for example, hydrocarbons, etc.) in the air stream; and (7) contaminants that may have been adsorbed by the carbon under prior service conditions.

1.3 *This standard does not purport to address all of the safety concerns, if any, associated with its use. It is the responsibility of the user of this standard to establish appropriate safety and health practices and determine the applicability of regulatory limitations prior to use.* Specific precautionary statements are given in Section 7.

2. Referenced Documents

2.1 ASTM Standards:

- D 2652 Terminology Relating to Activated Carbon²
- D 2854 Test Method for Apparent Density of Activated Carbon²
- D 3195 Practice for Rotameter Calibration³
- E 11 Specification for Wire-Cloth Sieves for Testing Purposes⁴
- E 220 Method for Calibration of Thermocouples by Comparison Techniques⁵

¹ This test method is under the jurisdiction of ASTM Committee D-28 on Activated Carbon, and is the direct responsibility of Subcommittee D 28.04 on Gas Evaluation Tests.

Current edition approved June 25, 1976. Published October 1976.

² Annual Book of ASTM Standards, Vol 15.01.

³ Annual Book of ASTM Standards, Vol 11.03.

⁴ Annual Book of ASTM Standards, Vol 14.02.

⁵ Annual Book of ASTM Standards, Vol 14.03.

E 300 Practice for Sampling Industrial Chemicals⁶

3. Terminology

3.1 *Definitions*—Terms relating to this test method are defined in Terminology D 2652.

4. Summary of Test Method

4.1 A sample of carbon is exposed to a heated air stream, the temperature of which is slowly increased until the carbon ignites. The temperature of the carbon bed and of the air entering the bed are recorded, and ignition is defined as the point at which the carbon temperature suddenly rises above the temperature of the air entering the bed.

5. Significance and Use

5.1 Activated carbons used in gas-phase adsorption may be subjected to heating, either from heat applied externally to the carbon bed, or heat generated by radioactive⁷ contaminants, or by the adsorption process itself. If the application of heat is sudden, or if no ample means to conduct the heat from the carbon bed exists, the carbon bed may ignite. This test method provides a controlled laboratory test to determine the temperatures at which such ignition occurs. As stated in 1.2, this does not necessarily give the temperature at which ignition will occur under a specific bed operating condition. This test method does, however, allow some ranking of carbons with regard to ignition temperature, and is a useful quality-control method for unused carbons.

6. Apparatus

6.1 *Quartz Ignition Tube and Sample Holder*, as shown in Fig. 1.

6.2 *Thermocouples*, Chromel-Alumel with Inconel sheath, 0.635-mm diameter, three required.

6.3 *Supply of Clean, Dry, Oil-Free Air*—The air must be passed through a HEPA filter and a bed of activated carbon containing at least 300 mL of carbon per litre per minute of air flow. Relative humidity of the air must be less than 5 % at 25°C.

6.4 *Flowmeter*, capable of metering air flow rates to 20 L/min.

⁶ Annual Book of ASTM Standards, Vol 15.05.

⁷ Milham and Kovoch, "Treatment of Airborne Radioactive Wastes," International Atomic Energy Agency, Vienna, 1968. (Paper SM-110/49).

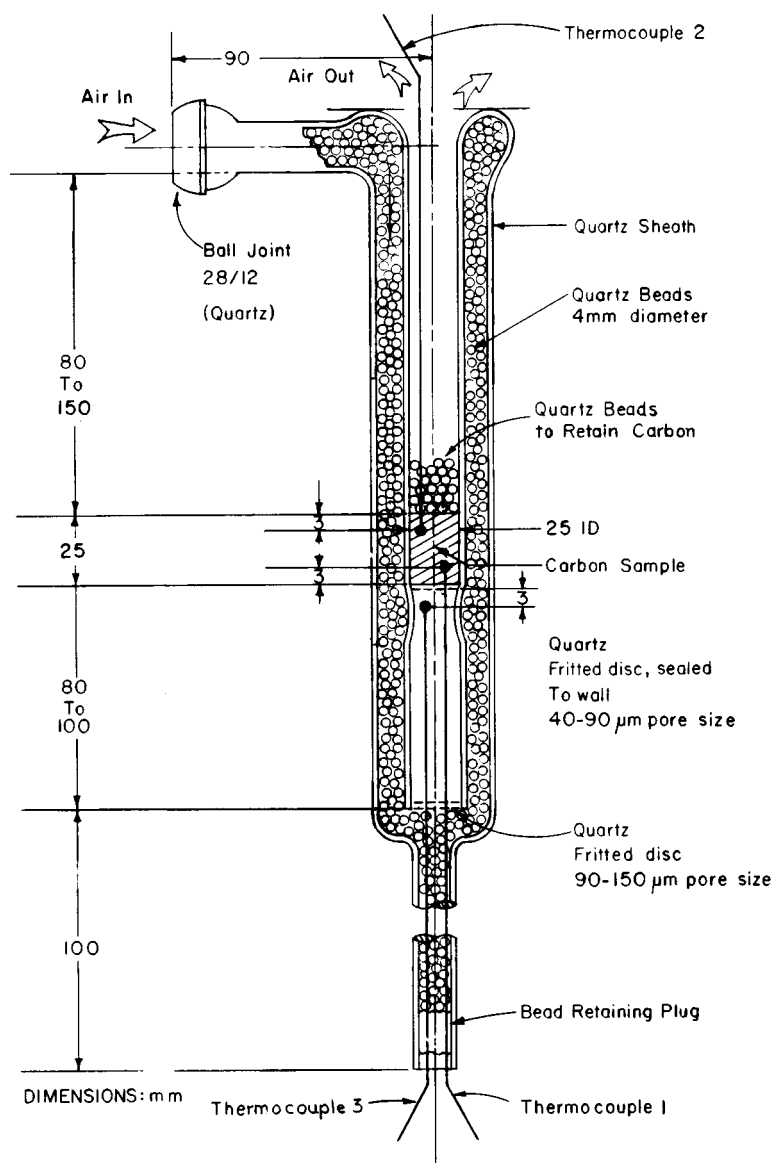

FIG. 1 Ignition Tube and Sample Assembly

6.5 Heating Mantle, tape, or oven to surround the ignition tube; at least 50 W.

6.6 Variable Transformer or temperature programmer for heater.

6.7 Supply of Compressed Nitrogen.

6.8 Quartz Beads, 4-mm in diameter or smaller as needed to prevent fluidization.

6.9 Sieves, (two) 76.2-mm in diameter, 150- μ m conforming to Specification E 11.

6.10 Potentiometric Recorder or equivalent readout for thermocouples (3 or more points).

6.11 Programmable Temperature Controller (Optional).

7. Hazards

7.1 The temperature rise in a carbon bed is quite sudden at ignition. An adequate supply of nitrogen and an operator must be present to quench the fire when this rise occurs. Do not stop nitrogen flow until all thermocouples indicate temperatures substantially below ignition.

7.2 Combustion products of carbon or carbon impregnants may be toxic. It is advisable to conduct this test in a fume hood.

8. Sampling

8.1 Guidance in sampling granular activated carbon is given in Practice E 300.

9. Preparation of Apparatus

9.1 Assemble apparatus as shown in Fig. 1 and Fig. 2.

9.2 Leak test the assembly and eliminate any leakage.

9.3 Obtain a representative sample of carbon of approximately 35 mL in accordance with Practice E 300. Blow clean dry oil-free air through the sample, retained between 150- μ m sieves, to remove carbon dust. The flow velocity through the sieves shall be 60 ± 20 m/min.

9.4 Fill the ignition tube (Fig. 1) to a depth of 25 ± 1 mm, using the apparatus and procedure described in Test Method D 2854. Cover the sample with quartz beads to a depth of at least 15 mm to prevent fluidization of the carbon bed.

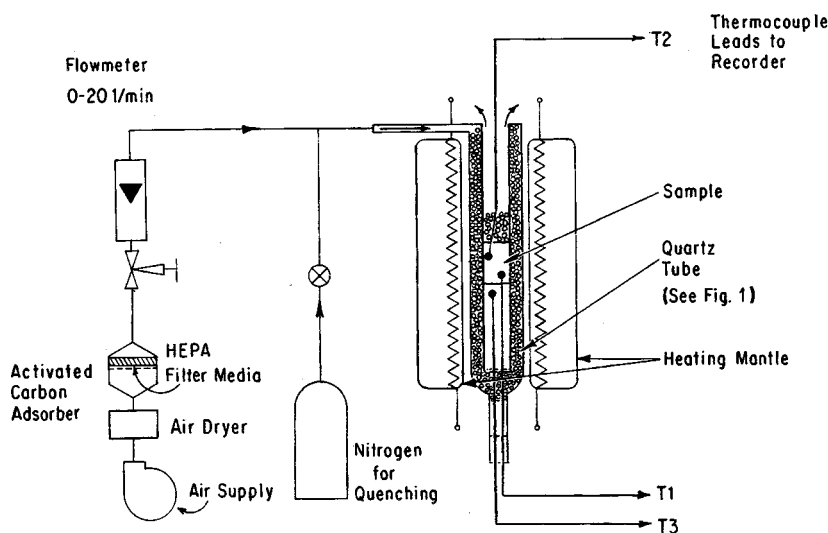

FIG. 2 Ignition Apparatus Schematic

10. Calibration

10.1 Thermocouples, recorder, and flowmeters require periodic calibration by standard laboratory techniques, for example, Method E 220, for thermocouples, and Practice D 3195, for rotometer—type flowmeters.

11. Procedure

11.1 Adjust the air flow rate to 14.7 ± 0.3 L/min, equivalent to a superficial velocity of 30 ± 0.5 m/min.

11.2 Adjust the variable transformer or temperature programmer to increase the temperature of the air stream reaching the sample at a rate of approximately $10^\circ\text{C}/\text{min}$ (as indicated by Thermocouple T-13). Continue until air temperature reaches approximately 150°C , or when the air temperature is approximately 50°C below the anticipated ignition temperature of the sample. At this point, adjust the variable transformer or program drive to reduce the air heating rate to approximately 2 to $3^\circ\text{C}/\text{min}$.

11.3 Maintain the heating rate of 2 to $3^\circ\text{C}/\text{min}$ until ignition is achieved, as indicated by a sudden rise in the temperature measured by thermocouple T-1 or T-2.

11.4 On ignition, cut off air flow immediately and introduce nitrogen to quench fire.

12. Interpretation of Results

12.1 Obtain time-temperature plots, Fig. 3, of the temperatures measured by thermocouples T-1 and T-2. Draw tangents to the heating curves before and after ignition, as shown in Fig. 3; ignition temperature is the intersection of the tangents. Repeat for thermocouple T-1. The ignition temperature for the carbon is defined from the thermocouple that first shows ignition.

13. Report

13.1 Report the following information:

- 13.1.1 Name of the carbon manufacturer,
- 13.1.2 Grade designation and nominal particle size range,
- 13.1.3 Average ignition temperature and whether ignition occurred first at the upstream (T-1) or downstream (T-2) thermocouple,
- 13.1.4 Temperature of the inlet air at the time of ignition,
- 13.1.5 Name of the agency and technician making the test, and
- 13.1.6 Identification number and date of the test.

14. Precision and Bias

14.1 The bias of this test method is basically the bias of the thermocouple-recorder system. The sensitivity of the ignition point to gas velocity varies from carbon to carbon. Milham and Kovach have reported a maximum rate of change of ignition point of $250^\circ\text{C}/(\text{m}/\text{s})$. Thus, the control of flow to ± 0.5 m/min, (0.0083 m/s) required in 11.1, should introduce no more than $\pm 2^\circ\text{C}$ error in the measurement. Such repeatability appears to have been obtained in the above-mentioned studies, when one considers reasonable variations in properties for successive samples of the same carbons; the actual ignition temperature spread at a given velocity did not exceed $\pm 5^\circ\text{C}$ in the vicinity of 500°C .

15. Keywords

- 15.1 activated carbon

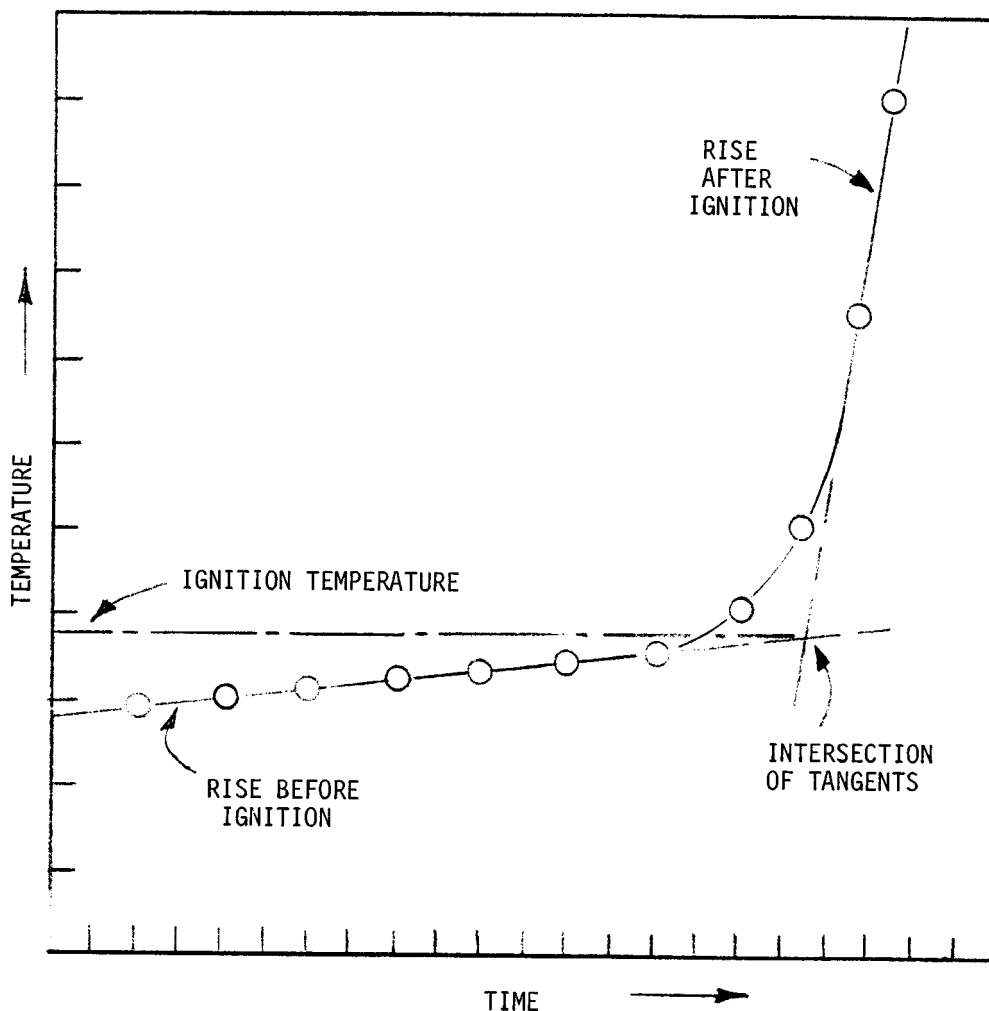

FIG. 3 Determination of Temperature of Carbon at Ignition

The American Society for Testing and Materials takes no position respecting the validity of any patent rights asserted in connection with any item mentioned in this standard. Users of this standard are expressly advised that determination of the validity of any such patent rights, and the risk of infringement of such rights, are entirely their own responsibility.

This standard is subject to revision at any time by the responsible technical committee and must be reviewed every five years and if not revised, either reapproved or withdrawn. Your comments are invited either for revision of this standard or for additional standards and should be addressed to ASTM Headquarters. Your comments will receive careful consideration at a meeting of the responsible technical committee, which you may attend. If you feel that your comments have not received a fair hearing you should make your views known to the ASTM Committee on Standards, 100 Barr Harbor Drive, West Conshohocken, PA 19428.