



Standard Test Method for Determining Electrolytic Corrosion of Copper by Adhesives¹

This standard is issued under the fixed designation D 3482; the number immediately following the designation indicates the year of original adoption or, in the case of revision, the year of last revision. A number in parentheses indicates the year of last reapproval. A superscript epsilon (ϵ) indicates an editorial change since the last revision or reapproval.

This standard has been approved for use by agencies of the Department of Defense.

1. Scope

1.1 This test method covers the determination of whether an adhesive has any corrosive effect on copper. It is ordinarily intended to distinguish materials that might cause corrosion in electrical and electronic equipment. This procedure is a subjective test for which precision and accuracy have not been established. It is not recommended for adhesives on backing.

1.2 The values stated in SI units are to be regarded as the standard. The values given in parentheses are for information only.

1.3 *This standard does not purport to address all of the safety concerns, if any, associated with its use. It is the responsibility of the user of this standard to establish appropriate safety and health practices and determine the applicability of regulatory limitations prior to use.*

2. Referenced Documents

2.1 ASTM Standards:

D 907 Terminology of Adhesives²

D 996 Terminology of Packaging and Distribution Environments³

E 104 Practice for Maintaining Constant Relative Humidity by Means of Aqueous Solutions⁴

G 15 Terminology Relating to Corrosion and Corrosion Testing⁵

3. Terminology

3.1 *Definitions*—Definitions of terms in this test method may be found in Terminologies D 907 and D 996.

3.1.1 *electrolytic corrosion, n*—the corrosion of metal resulting from current flow under an electrical potential in the presence of moisture.

4. Summary of Test Method

4.1 Two parallel helices of fine copper wire are laid in etched grooves on a glass tube. The adhesive material is coated

over the wires and the tube and then allowed to set or cure. The wired tube is exposed to high humidity with a d-c potential applied between the wires. Corrosion products are observed visually.

5. Significance and Use

5.1 Adhesives can be exposed to both electrical potential and humidity in many electrical and electronic applications. It is therefore desirable to provide a means of examining the corrosive tendencies of certain adhesives towards metals.

5.2 Although electrolytic corrosion is a direct result of ionic conduction in the adhesive, the nature of the exposed metals will have a bearing on both the severity of metal attack and the visibility of corrosion products. Because it gives a visual indication of corrosion and because of its widespread use in electrical circuits, copper is used in this test method. However, this would not preclude the use of other metals for specific interests.

5.3 This procedure is a subjective test in that determinations of the presence of corrosion is based on a visual inspection for a green discoloration or other evidence of corrosion.

6. Apparatus and Material

6.1 *Motor (Optional)*, low-speed, approximately 10 r/min for winding wire helices.

6.2 *Oven (or Temperature-Controlled Chamber)*, circulating-air, or chamber controlled at $39.5 \pm 1^\circ\text{C}$ ($95 \pm 2^\circ\text{F}$), unless otherwise specified.

6.3 *Battery, 45-V*, or equivalent source of d-c power.

6.4 *Corrosion Test Apparatus*—See Fig. 1.

6.4.1 *Helically Etched Glass Tubing*—See Fig. 2.

6.4.2 *Wire*,⁶ No. 36 Awg, 0.13 mm (0.005 in.) in diameter, OFHC (Oxygen-Free High-Conductivity) bare copper wire.

6.4.3 *Test Tube*, borosilicate glass, 32 mm (1 1/2 in.) in outside diameter, 200 mm (8 in.) long.

6.4.4 *Rubber Stopper*, No. 6, neoprene.

6.5 *Miscellaneous*— Soldering iron, rosin-core solder, thin polyethylene film, insulated wire, etc.

7. Procedure

7.1 Rinse a chemically cleaned helically etched glass tube

¹ This test method is under the jurisdiction of ASTM Committee D-14 on Adhesives and is the direct responsibility of Subcommittee D14.80 on Metal Bonding Adhesives.

Current edition approved March 30, 1990. Published May 1990. Originally published as D 3482 – 76. Last previous edition D 3482 – 76 (1987).

² *Annual Book of ASTM Standards*, Vol 15.06.

³ *Annual Book of ASTM Standards*, Vol 15.09.

⁴ *Annual Book of ASTM Standards*, Vol 11.03.

⁵ *Annual Book of ASTM Standards*, Vol 03.02.

⁶ Wire from Anaconda Wire and Cable Co., 605 3rd Ave., New York, NY 10016, has been found satisfactory.

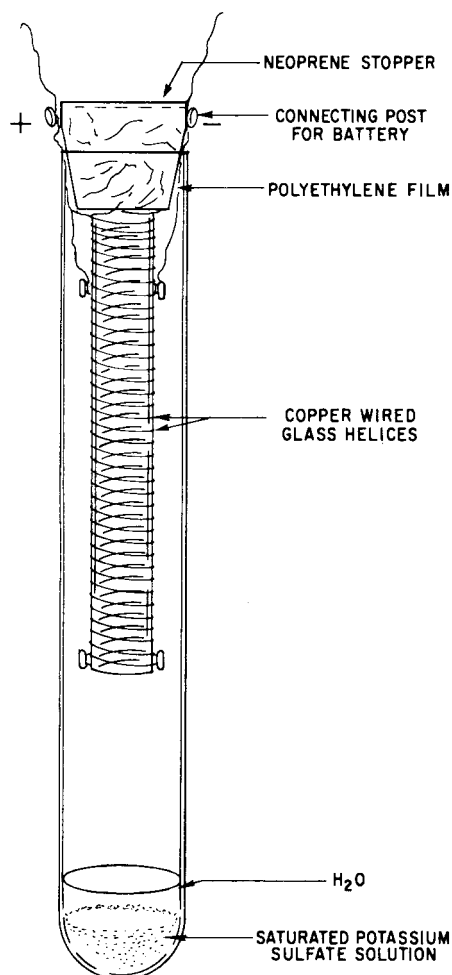

FIG. 1 Corrosion Test Apparatus

with distilled water and air dry. Keep clean until ready for use.

7.2 Clean copper wire by immersing in fresh 1,1,1-trichloroethane and wiping with clean, lint-free cloth. When materials are cleaned, handle them only with clean white gloves, clean tongs, or other suitable implements.

7.3 Attach the tube to the motor drive shaft and manually lay the wire around the small knobs on the tube. Repeat with another length of wire in the adjacent groove. Avoid excess tension on the wire as this may lead to drawing.

7.4 Cover one end of the tube with a thin film of polyethylene, roughly 75 mm (3 in.) to 100 mm (4 in.) across, and insert the tube into a 16-mm ($\frac{5}{8}$ -in.) inside diameter by 13-mm ($\frac{1}{2}$ -in.) deep hole centered in the small end of a neoprene stopper.

7.5 Make solder connections of the helically wound wires to diametrically opposed connecting posts inserted in the neoprene stopper (Note 1). Clip excess wire from the opposite end of the tube.

NOTE 1—Short lengths of 14-gage tinned copper wire have worked satisfactory as connecting posts.

7.6 Apply two thin uniform applications of the test adhesive in approximately 6-mm ($\frac{1}{4}$ -in.) wide uniform stripes of the material to be tested 180° apart over the entire exposed length of the test apparatus. Allow the material to set or cure in accordance with the manufacturer's recommendations.

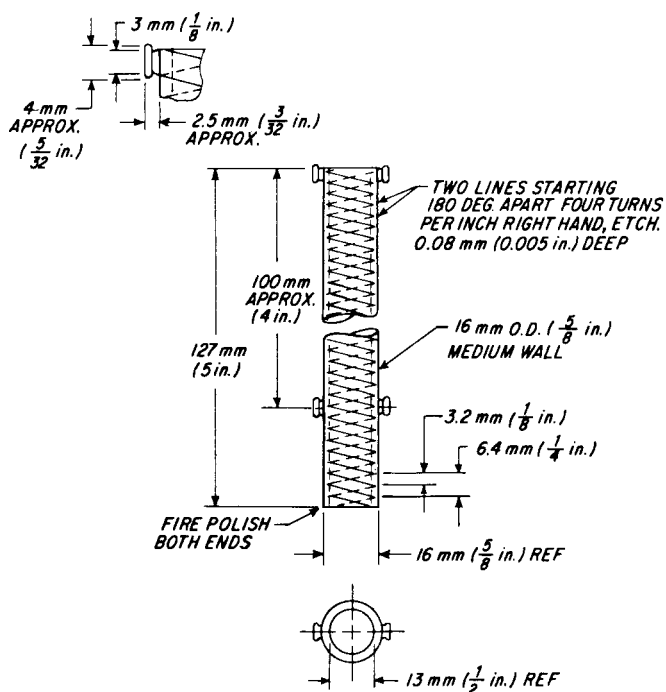

FIG. 2 Glass Tube

NOTE 1—MATERIAL: Glass, Pyrex No. 7740 by Corning Glass Works, Corning, NY, may be obtained from Kontes Glass Co., Vineland, NJ. Request Part No. 0022037-0101.

7.6.1 For adhesive systems which are air-inhibited or contain volatile, reactive constituents, wrap the test apparatus with a suitable nonadherent, inert film. Polyethylene, polypropylene, TFE-fluorocarbon, or similar films may be used. For air-inhibited adhesive systems, polyethylene and polypropylene are not recommended. If one of these films is used to cover the test adhesive, remove the nonadherent film from the test apparatus after the adhesive system has set or cured and before subjecting the specimen to humidity exposure.

NOTE 2—For extremely critical applications, room- and moderate-temperature curing adhesives may be subjected to the testing environment during cure if mutually agreed.

7.7 Control temperature and relative humidity, when specified, in accordance with Practice E 104, Method C.

NOTE 3—For example, for 96 % relative humidity at 35°C (95°F) place 2 to 3 g of potassium sulfate in a test tube and cover with a saturated solution of the same salt in distilled water to about a 25-mm (1-in.) depth.

7.8 Before placing the assembly in the test tube, the external leads should be temporarily connected to the d-c voltage source, and then the leads of a d-c voltmeter should be touched to the bottom ends of the two test wires on the coated tube to check that the applied voltage is present throughout the test wires under the adhesive.

7.9 Insert the wired, coated tube and rubber stopper in the test tube, keeping the polyethylene film between the rubber and wire leads.

7.10 Place the tube in the oven or temperature-controlled chamber and connect the leads externally to a 45-V battery or equivalent power source.

7.11 Examine the wires visually with the aid of a 5-power

magnifying glass for green discoloration or other visible evidence of corrosion. Observe at the end of 1 and 3 days, and periodically thereafter up to 15 days, or for the period of time specifically required. Use blanks of known corrosive or non-corrosive controls.

8. Report

8.1 Report the following where applicable:

- 8.1.1 Description of curing agents or additives,
- 8.1.2 Formulation,
- 8.1.3 Method of setting or curing (including description of covering film),
- 8.1.4 Temperature and humidity of test,
- 8.1.5 Period of exposure for each examination,
- 8.1.6 Observation notes,

8.1.7 Indication of whether positive or negative wire was involved, and

8.1.8 Indication of location(s) of wire corrosion, that is, (a) on portions of wire free of adhesive, (b) under adhesive coating, (c) at air-wire-adhesive interface.

9. Precision and Bias

9.1 Precision and bias statements for this test method cannot be established, because the test is subjective. The visual interpretation of the presence of corrosion is a judgement evaluation, and is not a practical basis for statements of this nature.

10. Keywords

10.1 adhesives; copper; corrosion; electrolytic

The American Society for Testing and Materials takes no position respecting the validity of any patent rights asserted in connection with any item mentioned in this standard. Users of this standard are expressly advised that determination of the validity of any such patent rights, and the risk of infringement of such rights, are entirely their own responsibility.

This standard is subject to revision at any time by the responsible technical committee and must be reviewed every five years and if not revised, either reapproved or withdrawn. Your comments are invited either for revision of this standard or for additional standards and should be addressed to ASTM Headquarters. Your comments will receive careful consideration at a meeting of the responsible technical committee, which you may attend. If you feel that your comments have not received a fair hearing you should make your views known to the ASTM Committee on Standards, at the address shown below.

This standard is copyrighted by ASTM, 100 Barr Harbor Drive, PO Box C700, West Conshohocken, PA 19428-2959, United States. Individual reprints (single or multiple copies) of this standard may be obtained by contacting ASTM at the above address or at 610-832-9585 (phone), 610-832-9555 (fax), or service@astm.org (e-mail); or through the ASTM website (www.astm.org).