



# Standard Test Method for Pilling Resistance and Other Related Surface Changes of Textile Fabrics: Brush Pilling Tester<sup>1</sup>

This standard is issued under the fixed designation D 3511; the number immediately following the designation indicates the year of original adoption or, in the case of revision, the year of last revision. A number in parentheses indicates the year of last reapproval. A superscript epsilon ( $\epsilon$ ) indicates an editorial change since the last revision or reapproval.

## 1. Scope

1.1 This test method covers the determination of the propensity of a fabric to form pills from fuzz under test conditions intended to simulate normal wear using the brush pilling tester. This procedure is generally applicable to all types of apparel fabrics including both woven and knitted fabrics.

NOTE 1—For other test methods for the pilling resistance of textiles, refer to Test Methods D 3512, D 3514, and D 4970.

1.2 The values stated in either SI units or inch-pound units are to be regarded separately as the standard. Within the text, the inch-pound units are to be regarded separately as the standard. Within the text, the inch-pound units are shown in parentheses. The values stated in each system are not exact equivalents; therefore, each system shall be used independently of the other. Combining values from the two systems may result in nonconformance with the specification.

1.3 *This standard does not purport to address all of the safety concerns, if any, associated with its use. It is the responsibility of the user of this standard to establish appropriate safety and health practices and determine the applicability of regulatory limitations prior to use.*

## 2. Referenced Documents

### 2.1 ASTM Standards:

D 123 Terminology Relating to Textiles<sup>2</sup>

D 1776 Practice for Conditioning and Testing Textiles<sup>2</sup>

D 3512 Test Method for Pilling Resistance and Other Related Surface Changes of Textile Fabrics: Random Tumble Pilling Tester<sup>3</sup>

D 3514 Test Method for Pilling Resistance and Other Related Surface Changes of Textile Fabrics: Elastomeric Pad<sup>3</sup>

D 4970 Test Method for Pilling Resistance and Other Related Surface Changes of Textile Fabrics (Martindale Pressure Tester Method)<sup>3</sup>

### 2.2 ASTM Adjuncts:

ADJD3512 Set of 5 Photographic Standards for Random Tumble Pilling Test<sup>4</sup>

## 3. Terminology

### 3.1 Definitions:

3.1.1 *fuzz, n*—untangled fiber ends that protrude from the surface of a yarn or fabric.

3.1.2 *pilling resistance, n*—resistance to the formation of pills on the surface of a textile fabric.

3.1.3 *pills, n*—bunches or balls of tangled fibers which are held to the surface of a fabric by one or more fibers.

3.1.4 For definitions of other textile terms used in this test method, refer to Terminology D 123.

## 4. Summary of Test Method

4.1 Pilling and other changes in surface appearance, such as fuzzing, which occur in normal wear are simulated on laboratory testing machines. Fabrics are subjected to simulated wear conditions: first brushing the specimens to free fiber ends that form fuzz on the surface of the fabric, then rubbing two of the specimens together in circular motion to roll the fiber ends into pills. The degree of fabric pilling is evaluated by comparing the tested specimens with visual standards, which may be actual fabrics or photographs of fabrics, showing a range of pilling resistance. The observed resistance to pilling is reported using an arbitrary rating scale.

## 5. Significance and Use

5.1 *Acceptance Testing*—This test method for fabrics for resistance to pilling is not recommended for acceptance testing. If it is used for acceptance testing, it should be used with caution because interlaboratory data are not available. In some cases the purchaser and the supplier may have to test a commercial shipment of one or more specific materials by the best available method, even though the method has not been recommended for acceptance testing.

5.1.1 If there are differences or practical significance between reported test results for two laboratories (or more), comparative tests should be performed to determine if there is a statistical bias between them, using competent statistical

<sup>1</sup> This test method is under the jurisdiction of ASTM Committee D13 on Textiles and is the direct responsibility of Subcommittee D13.60 on Fabric Test Methods, Specific.

Current edition approved April 10, 2002. Published July 2002. Originally published as D 3511 – 76. Last previous edition D 3511 – 99a.

<sup>2</sup> *Annual Book of ASTM Standards*, Vol 07.01.

<sup>3</sup> *Annual Book of ASTM Standards*, Vol 07.02.

<sup>4</sup> The Brush Pilling Tester manufactured by Standard Scientific Supply Co., 601 W. Market St., Bethlehem, PA 18018-5208 has been found satisfactory.

assistance. As a minimum, the test samples should be used that are as homogeneous as possible, drawn from the material from which the disparate test results were obtained, and randomly assigned in equal numbers to each laboratory for testing. Other materials with established test values may be used for this purpose. The test results from the two laboratories should be compared using a statistical test for unpaired data, at a probability level chosen to the testing series. If a bias is found, either its cause must be found and corrected, or future test results must be adjusted in consideration of the known bias.

5.2 The pilling of textile fabrics is a very complex property because it is affected by many factors which may include type of fiber or blends, fiber dimensions, yarn and fabric construction, fabric finishing treatments and refurbishing method. Testing before refurbishing may be advisable. The pilling resistance of a specific fabric in actual wear varies more with general conditions of use and individual wearers than in replicate fabric specimens subjected to controlled laboratory tests. This experience should be borne in mind when adopting levels of acceptability for any series of standards.

5.3 Pills vary appreciably in size and appearance and depend on the presence of lint and degree of color contrast. These factors are not evaluated when pilling is rated solely on the number of pills. The development of pills may be accompanied by other surface phenomena such as loss of cover, color change, or the development of fuzz. Since the overall acceptability of a specific fabric is dependent on both the characteristics of the pills and the other factors affecting surface appearance, it is suggested that fabrics tested in the laboratory be evaluated subjectively with regard to their acceptability and not rated solely on the number of pills developed. A series of standards, based on graduated degrees of surface change of the fabric type being tested, may be set up to provide a basis for subjective ratings. The visual standards are most advantageous when the laboratory test specimens correlate closely in appearance with worn fabrics and show a similar ratio of pills to fuzz. Counting the pills and weighing their number with respect to their size and contrast, as a combined measure of pilling resistance, is not recommended because of the excessive time required for counting, sizing, and calculation.

5.4 The degree of fabric pilling is evaluated by comparing the tested specimens with visual standards, which may be actual fabrics or photographs of fabrics, showing a range of pilling resistance. The observed resistance to pilling is reported on an arbitrary scale ranging from 5 (no pilling) to 1 (very severe pilling).

5.5 This test method is applicable to a wide variety of woven and knitted fabrics that vary in pilling propensity as a result of variations in fiber, yarn & fabric structure, and finish.

## 6. Apparatus and Materials

6.1 *Brush Pilling Tester*<sup>4</sup>, (Fig. 1), consisting of the parts described as follows:

6.1.1 *Rotating Platform*, which operates on a 19-mm (0.75-in.) radius at 6.1 rad/s (1r/s).

6.1.2 *Nylon Brushes*, mounted on plywood holders, each of which is removable and is fitted to the rotating platform. The specifications for the brushes and accessories are as follows:

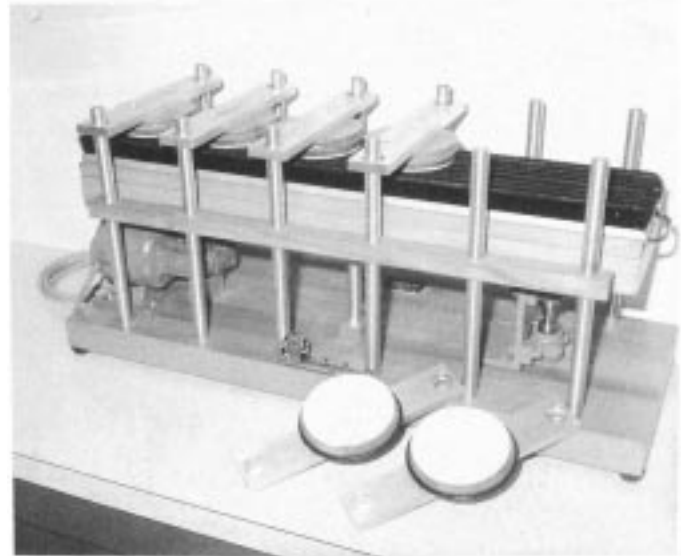

**FIG. 1 Brush Pilling Tester**

6.1.2.1 *Brushes*<sup>5</sup>—Fuller Gript Brush Strip, No. 8B904113, 790 mm (31 in.) long; eight per tester.

6.1.2.2 *Brush Strip Height*—A height of 24 mm (.94 in.) with an overall height of 32 mm (1.25 in.), including the backing but not the 9C-7200 holders.

6.1.2.3 *Brush Bristles*—Black nylon, 0.25-mm (10-mil) diameter.

6.1.2.4 *Brush Holders*—Fuller Brush No. 9C-7200,<sup>5</sup> 2-strip channel, 790 mm (31 in.) long.

6.1.2.5 *Brush Mounting*—9C-7200 holders spaced 35 mm (1.37 in.) center hole to center hole.

6.1.2.6 *Emery Paper 320*—Grit for sanding brushes.

6.1.2.7 *Cleaning Solvent*, acetone or other appropriate solvent to clean brushes (see 13).

6.1.3 *Specimen Holder*, (Fig. 2), six, each weighing  $660 \pm 5$  g, on which the fabric specimens are mounted. The face of the holders shall be covered with 3-mm (0.13 in) thick by 108-mm (4.25-in.) diameter soft cellular rubber<sup>6</sup> to prevent specimen slippage during testing.

6.2 *Apparatus for Fabric Evaluation*<sup>6</sup>—Facilities for illumination (cool white fluorescent tube) and simultaneous viewing of test specimen and fabric or photographic rating standards. Apparatus and options for visual evaluation are listed in Table 1

6.3 *Standard In-House Pilling Test Fabric*, having an established pilling resistance rating, for checking machine performance. No universal standard fabric is available. Each test facility must decide on an appropriate fabric.

6.4 *Rating Standards*:

6.4.1 *Fabric*—A series of tested specimens of a specific type in-house fabric, which shows degrees of pilling or other distortions, or both, for each type of fabric to be tested. Store

<sup>5</sup> The Fuller Brush Co., Industrial Division, Hartford, CT 06115.

<sup>6</sup> Available from Standard Scientific Supply Co., 601 W. Market St., Bethlehem, PA 18018-5208.

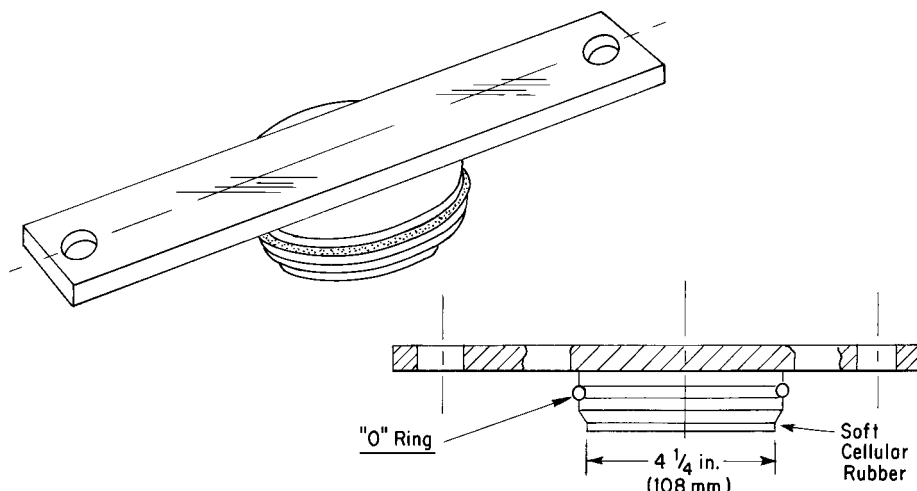

FIG. 2 Specimen Holder

TABLE 1 Viewing Apparatus and Options

Apparatus	Specimen Preparation
ASTM Lightbox (Fig. 3) <sup>A</sup>	0.78 rad (45°)
Lightbox <sup>B</sup>	0.78 rad (45°)
Lightbox <sup>B</sup>	flat
Lightbox <sup>B</sup>	critical angle
As determined by the buyer and supplier	

<sup>A</sup>The source of supply of the apparatus known to the committee at this time is Standard Scientific Supply Co., 601 West Market Street, Bethlehem, PA 18018-5208. If you are aware of alternate suppliers, please provide this information to ASTM Headquarters. Your comments will receive careful consideration at a meeting of the responsible technical committee, which you may attend.

<sup>B</sup>Available commercially.

the in-house fabric rating standards and handle them under conditions that will preserve their original form and appearance.

6.4.2 *Photographic*—A set of five photographs, 105 mm square (4.13 in.), numbered 1 to 5, illustrating varying degrees of pilling from “very severe pilling” to “no pilling”, such as Adjunct D 3512<sup>7</sup>. The photos should have a dull matte finish and be of the same size as the tested specimen.

6.5 *Facilities for Laundering Samples*—If needed.

6.6 *Facilities for Drycleaning Samples*—If needed.

## 7. Hazardous Materials

7.1 Solvents used in this test method may be hazardous. Refer to the manufacturer’s material safety data sheets for information on use, handling, storage, and disposal of these products.

## 8. Sampling

8.1 *Primary Sampling Unit*—Consider rolls of fabric or fabric components of fabricated systems to be the primary sampling unit, as applicable.

NOTE 2—An adequate specification or other agreement between the purchaser and the supplier requires taking into account the variability

<sup>7</sup> Available from ASTM Headquarters, 100 Barr Harbor Drive, West Conshohocken, PA 19428. Request ADJD3512.

among rolls, bolts, or pieces of fabric and among specimens from a swatch of fabric from a roll, bolt, or piece, or between cartons of garments and among garments within a carton, to provide a sampling plan with a meaningful producer’s risk, consumer’s risk, acceptable quality level, and limiting quality level.

8.2 *Laboratory Sampling Unit*—From each primary sampling unit take one full-width piece of fabric that is 1 m (1 yd) in length along the selvage (machine direction), after first removing a 1 m (1 yd) length. For fabric components of fabricated systems use the entire system.

8.2.1 For acceptance testing of garments, take one garment from each carton (see Note 2).

## 9. Test Specimens: Selection, Number, and Preparation

9.1 Samples may be washed or dry cleaned before cutting the test specimens, using conditions appropriate for the fabric end use or conditions agreed upon by all interested parties.

9.2 Cut specimens in squares  $320 \pm 1$  mm ( $9 \pm 0.05$  in.) with the sides parallel to the warp (wale) and filling (course) directions or circles having a diameter of  $175 \pm 2$  mm ( $7 \pm 0.1$  in.)

9.2.1 Take six specimens, two each from the right, center, and left areas of each laboratory sampling unit. Take the specimens evenly spaced across the width of the laboratory sample or from three different panels in a garment. Specimens should be staggered in such a manner that no specimens contain the same yarns. Avoid areas with wrinkles and other distortions. Avoid getting oil, water, grease, etc. on the specimen when handling. Unless otherwise specified, do not cut specimens nearer the selvage than one tenth the width of the fabric.

9.3 Mark warp (wale) and filling (course) direction on the edge of each specimen.

9.3.1 Mark the replicate specimens as *AL, BL; AC, BC; and AR, BR* with *L, C, and R* indicating left, center, and right areas of the fabric width.

## 10. Preparation of Apparatus

10.1 *Maintenance Checks:*

10.1.1 Check the operation of the pilling tester with one or

more standard in-house fabrics of known pilling resistance as directed as follows:

10.1.1.1 If the tester is in daily use, check the tester using the standard fabric(s) at least once a week.

10.1.1.2 If testing is done infrequently, check the tester using the standard fabric(s) each time it is used.

10.1.2 If the tester is used daily, clean the brushes with a suitable solvent such as acetone (see 7.1), remove any lint with a hand card, and clip any protruding bristles at least once a week. If testing is done infrequently, check for these conditions before each testing session.

#### 10.2 Corrective Action:

10.2.1 If the results obtained on the standard fabric are not in agreement with the established values, clean the brushes as directed in 10.1.2.

10.2.2 If cleaning fails to produce results which equate the established values, sand the brushes with emery paper mounted on the specimen holders.

10.2.3 Continue testing until results are acceptable, or until a replacement set of in-house standards is established.

### 11. Conditioning

11.1 Bring the test specimens to moisture equilibrium for testing in the standard atmosphere for testing textiles as directed in Practice D 1776 or, if applicable, in the specified atmosphere in which the testing is to be performed

### 12. Procedure

12.1 Make all tests in the standard atmosphere for testing textiles.

12.2 Place the brush board on the 19.0-mm (0.75-in.) radius rotating platform with the bristles pointing upwards.

12.3 Mount the six specimens on the six holders, fabric face exposed and under sufficient tension to prevent wrinkling. Place the specimen holders over the vertical positioning pins so that the fabric face makes contact with the brush bristles.

12.4 Brush the specimens 4 min  $\pm$  10 s.

NOTE 3—The test time intervals used should reproduce the appearance of actual wear as seen in garments made from the specific type of fabric under test. The test time intervals for brushing and pilling specified in 12.4 and 12.5 have been found satisfactory for most clear-finish suitings, lightweight shirtings, and blouse fabrics. Woolen system blends such as flannels and other soft fabrics may require modification of the preceding procedure even to the exclusion of the brushing treatment or to lowering the pressure on the specimen by using lighter-weight specimen holders. Cross checking with actual wear tests is considered essential for determining any commercial acceptability.

12.5 Place the three holders with specimens marked “BL,” “BC,” and “BR” on the 9-mm (0.75-in.) radius rotating platform with the fabric face of “B” specimens exposed and facing up and the three pins in the back of the holder mated with the corresponding holes in the platform. Place the remaining three fabric holders, with the “A” specimens, fabric face exposed and facing “B,” over the vertical positioning pins so that the face-to-face contact is made with the lower set of specimens; BL matches with AL; BC with AC; BR with AR. Run the pilling tester for 2 min  $\pm$  10 s (see Notes 2 and 3).

### 13. Evaluation

13.1 Using the viewing apparatus and option selected from

Table 1 and either suitable fabric or photographic standards (see 6.4), subjectively rate the appearance of the face of each A specimen using the following scale:

- 5—no pilling
- 4—slight pilling
- 3—moderate pilling
- 2—severe pilling
- 1—very severe pilling

NOTE 4—Rating standards assembled from tested specimens of the types of fabrics tested, representing the level of pilling equivalent to each of the five ratings, are valuable as a reference to ensure uniformity in rating. Individual laboratories should have available rating standards for each type of fabric of particular interest.

NOTE 5—If the test method is to be used as a referee method, a minimum of two graders, the agreed-upon standards, and the viewing apparatus and option selected from Table 1 for fabric evaluation shall be used.

13.1.1 Average the ratings for each laboratory sampling unit and for the lot.

13.2 Check the pilled specimens for nonuniformity of pilling. If pills are concentrated in any one strip in the length or width direction, or in any one portion of a specimen, report this condition. Strips indicate that different yarns may have been used to make the fabric being tested.

NOTE 6—If absolute rather than relative performance is the objective of the test, correlate the observed pilling test results with appropriate wear tests for each type of fabric.

13.3 Evaluate the fabric for other surface effects, such as fuzzing, if requested. It is advisable to develop a separate set of in-house fabric rating standards for each surface effect to be rated.

### 14. Report

14.1 State that the specimens were tested as directed in Test Method D 3511. Describe the material or product sampled and the method of sampling used.

14.2 Report the following information for the laboratory sampling unit and for the lot as applicable to a material specification or contract order.

14.2.1 Ratings of each individual specimen and the average rating of the three specimens from each laboratory sampling unit and the average for the lot,

14.2.2 If the sample fabric was washed before testing, laundering conditions used,

14.2.3 If the fabric was dry-cleaned before testing, the conditions used,

14.2.4 Running times, and

14.2.5 Type of viewing apparatus, viewing option, and rating standard used.

### 15. Precision and Bias

15.1 *Precision*—The repeatability standard deviation for 1 laboratory has been determined to be  $\pm$  0.35. The reproducibility of this test method is being determined and will be available during or before 2000.

15.2 *Bias*—The procedure of this test method produces a test value that can be defined only in terms of a test method. There is no independent, referee method by which bias may be determined. This test method has no known bias.

## 16. Keywords

### 16.1 fabric; fuzz; pills

*ASTM International takes no position respecting the validity of any patent rights asserted in connection with any item mentioned in this standard. Users of this standard are expressly advised that determination of the validity of any such patent rights, and the risk of infringement of such rights, are entirely their own responsibility.*

*This standard is subject to revision at any time by the responsible technical committee and must be reviewed every five years and if not revised, either reapproved or withdrawn. Your comments are invited either for revision of this standard or for additional standards and should be addressed to ASTM International Headquarters. Your comments will receive careful consideration at a meeting of the responsible technical committee, which you may attend. If you feel that your comments have not received a fair hearing you should make your views known to the ASTM Committee on Standards, at the address shown below.*

*This standard is copyrighted by ASTM International, 100 Barr Harbor Drive, PO Box C700, West Conshohocken, PA 19428-2959, United States. Individual reprints (single or multiple copies) of this standard may be obtained by contacting ASTM at the above address or at 610-832-9585 (phone), 610-832-9555 (fax), or [service@astm.org](mailto:service@astm.org) (e-mail); or through the ASTM website ([www.astm.org](http://www.astm.org)).*