



## Standard Test Methods for Shear Adhesion of Pressure-Sensitive Tapes<sup>1</sup>

This standard is issued under the fixed designation D 3654/D 3654M; the number immediately following the designation indicates the year of original adoption or, in the case of revision, the year of last revision. A number in parentheses indicates the year of last reapproval. A superscript epsilon ( $\epsilon$ ) indicates an editorial change since the last revision or reapproval.

### 1. Scope

1.1 This test method describes procedures for determining the ability of pressure-sensitive tapes to remain adhered under constant load applied parallel to the surface of the tape and substrate.

1.1.1 Procedure A measures the shear adhesion when applied to a vertical standard steel panel.

1.1.2 Procedure B measures the shear adhesion when applied to vertical panel covered with NIST SRM 1810A standard fiberboard.

1.1.3 Procedure C measures the shear adhesion when applied to a vertical panel covered with a fiberboard as defined by Comite Europeen de Normalisation (CEN).

1.1.4 Procedure D measures shear adhesion when applied to a vertical panel covered with a fiberboard agreed upon by the buyer and seller.

1.1.5 Procedure E measures shear adhesion of filament reinforced tape when applied to a horizontal standard steel panel.

1.1.6 Procedure F measures shear adhesion of a filament reinforced tape when applied to a horizontal panel covered with NIST SRM 1810A standard fiberboard.

1.1.7 Procedure G measures the shear adhesion of a filament reinforced tape when applied to a horizontal panel covered with a standard fiberboard defined by CEN.

1.1.8 Procedure H measures the shear adhesion the same as Procedure A except the test is conducted at an elevated temperature and after a 10-min dwell time at the elevated temperature.

1.2 These procedures provide a means of assessing the uniformity of the adhesive of a given type of pressure-sensitive tape, usually tapes used for packaging applications. The assessment may be within a roll of tape, between rolls or production lots.

1.2.1 Variations in the tape backing and adhesive affect the response; therefore, these procedures cannot be used to pinpoint the specific cause(s) of nonuniformity.

1.2.2 This test method is intended to replace AFERA 4012,

CEN 1943, and PSTC (see 7.2).

1.3 *This standard does not purport to address all of the safety concerns, if any, associated with its use. It is the responsibility of the user of this standard to establish appropriate safety and health practices and determine the applicability of regulatory limitations prior to use.*

### 2. Referenced Documents

#### 2.1 ASTM Standards:

A 666 Specification for Annealed or Cold-Worked Austenitic Stainless Steel, Sheet, Strip, Plate and Flat Bar<sup>2</sup>

D 3715/D 3715M Practice for Quality Assurance of Pressure-Sensitive Tapes<sup>3</sup>

D 5750/D 5750M Guide for Width and Length of Pressure-Sensitive Tape<sup>3</sup>

E 122 Practice for Choice of Sample Size to Estimate a Measure of Quality for a Lot or Process<sup>4</sup>

#### 2.2 AFERA Standard:

AFERA 4012 Self-Adhesive Tapes—Measurement of Static Shear Adhesion<sup>5</sup>

#### 2.3 CEN Standard:

EN 1943 Self-Adhesive Tapes—Measurement of Static Shear Adhesion<sup>6</sup>

#### 2.4 PSTC Standard:

PSTC-7 Holding Power of Pressure-Sensitive Tapes<sup>7</sup>

### 3. Summary of Test Method

3.1 *Procedure A, Shear Adhesion to Standard Steel Panel*—A strip of tape is applied to a standard steel panel under controlled roll down. The panel is mounted vertically, a standard mass is attached to the free end of the tape and the time to failure is determined.

3.2 *Procedure B, Shear Adhesion to a Standard (NIST) Fiberboard*—A strip of tape is applied to a panel covered with NIST SRM 1810A fiberboard under controlled roll down. The panel is mounted vertically, a standard mass is attached to the

<sup>2</sup> Annual Book of ASTM Standards, Vol 01.03.

<sup>3</sup> Annual Book of ASTM Standards, Vol 15.09.

<sup>4</sup> Annual Book of ASTM Standards, Vol 14.02.

<sup>5</sup> AFERA (Association des Fabricants Europeen de Rubans Auto-Adhesifs), LAM, Jaan Copes van Cattenburch 79, NL-2858 EW., the Hague, the Netherlands.

<sup>6</sup> EN (European Norm), available from COMITE Europeen de Normalisation, CEN Rue de Stassart, 36, B-1050, Brussels, Belgium.

<sup>7</sup> PSTC (Pressure Sensitive Tape Council), 400 N. Michigan Ave., No. 2200, Chicago, IL 60611-4267.

<sup>1</sup> This test method is under the jurisdiction of ASTM Committee D10 on Packaging and is the direct responsibility of Subcommittee D 10.14 on Tapes and Labels.

Current edition approved Oct. 10, 2002. Published December 2002. Originally approved in 1978. Last previous edition approved in 1996 as D 3654/D 3654M – 96<sup>ε</sup>.

free end of the tape and the time to failure determined.

**3.3 Procedure C, Shear Adhesion to a Standard CEN Fiberboard**—A strip of tape is applied to a panel covered with the CEN standard fiberboard under controlled roll down. The panel is mounted vertically, a standard mass is attached to the free end of the tape and the time to failure is determined.

**3.4 Procedure D, Shear Adhesion to a Fiberboard with Controlled Roll Down**—The panel is mounted vertically, a standard mass is attached to the free end of the tape and the time to failure is determined.

**3.5 Procedure E, Shear Adhesion to a Standard Steel Panel**—A strip of filament reinforced tape is applied to a standard steel panel with a 120° bend at one end with controlled roll down. The panel is mounted horizontally, tape side up, with the free end of the tape allowed to hang vertically over the rounded end. A standard mass is attached to the free end of the tape and allowed to act for the specified time.

**3.6 Procedure F, Shear Adhesion of Filament Reinforced Tape to a Standard (NIST) Fiberboard**—A strip of filament reinforced tape is applied to a panel with a 120° bend, covered with NIST SRM 1810A standard fiberboard under controlled roll down. The panel is mounted horizontally, tape side up, with the free end of the tape allowed to hang vertically over the round end of the panel. A standard mass is attached to the free end of the tape and allowed to act for a specified time.

**3.7 Procedure G, Shear Adhesion of a Filament Reinforced Tape to a CEN Standard Fiberboard**—A strip of filament reinforced tape is applied to a panel covered with CEN standard fiberboard under controlled roll down. The panel is mounted horizontally, tape side up, with the free end of the tape allowed to hang vertically over the round end of the panel. A standard mass is attached to the free end of the tape and allowed to act for the specified time.

**3.8 Procedure H**—This procedure is conducted as described in Procedure A except the test is conducted at an elevated temperature after a 10-min dwell time at the elevated temperature.

**3.9** For Procedures A, B, C, D, and H the preferred specimen size is 12 by 12 mm [0.5 by 0.5 in.]. A specimen size of 24 by 24 mm [1 by 1 in.] may be specified.

**3.10** For Procedures E, F and G the specimen width shall be 12 mm [0.5 in.]. For testing reinforced filament by Procedure H, the width shall be 12 mm [0.5 in.].

#### 4. Significance and Use

**4.1** Procedure A measures the ability of a pressure-sensitive tape to adhere to a standard steel panel under constant stress. This may or may not relate to the ability of the tape to adhere to other surfaces.

**4.2** Procedures B, C, and D may be used to determine the shear adhesion of the tapes generally used to close fiberboard boxes in packaging applications.

**4.3** Procedure D measures the shear adhesion of a pressure-sensitive tape to a nonstandard fiberboard, liner board, corrugated board, or other surfaces which is agreed upon for testing. This may be used to compare the shear adhesion of a tape to a particular fiberboard surface or to compare the shear adhesion of a tape to a variety of fiberboard surfaces.

**4.3.1** The surfaces of similar fiberboards may exhibit con-

siderable variation between mills, between batches from one mill, and within batches. Take care in the choice of samples and when comparing results between fiberboard surfaces which may not be exactly the same.

**4.3.2** The precision of tests conducted on nonstandard surfaces may be different than that described in Section 13.

**4.4** Procedures E, F, and G may be used to determine the ability of a filament reinforced tape to hold when placed under constant stress.

**4.5** Procedure H may be used to compare the shear adhesion of tape applied to a standard steel surface and tested at an elevated temperature. The use of an elevated temperature during test tends to reduce the duration of the test.

#### 5. Apparatus

**5.1 Specimen Cutter<sup>7,8,9</sup>**—The specimen cutter shall hold two single-edge razor blades in parallel planes, a precise distance apart, to form a cutter of exact specimen width. Two cutters, 12 mm [0.5 in.] and 24 mm [1 in.] cutting width, shall be available or appropriate alternates, which will not cause edge damage.

**NOTE 1**—The 12-mm [0.5-in.] cutter shall consist of a 12-mm [0.5-in.] thick by 200-mm [8-in.] length of aluminum bar stock 12-mm [0.5-in.] wide. The edges for about 125 mm [5 in.] from one end shall be rounded slightly to form a handle. The width of the bar for 75 mm [3 in.] shall be narrowed to exactly 12 mm [0.5 in.] minus the thickness of a single-edge razor (one of two used as cutting edges). The razor shall be held in position using side plates. The end of the cutter shall be cut away at a 45° angle to expose the cutting edges at one end of the blades. The edges shall be separated by 12 ± 0.10 mm [0.5 ± 0.005 in.]. The 24 mm [1 in.] cutter shall follow the same description except the bar stock shall be 24-mm [1-in.] wide and shall be narrowed to exactly 24 mm [1 in.] minus the thickness of a single edge razor.

**5.2 Dispensing System**, for solvents, such as a wash bottle.

**5.3 Panel<sup>7,9</sup>**:

**5.3.1** For Procedures A, B, C, D, and H, a 50 by 125 mm [2 by 5 in.] not less than 1.1 mm [0.043 in.] thickness 302 or 304 stainless steel sheet with bright annealed finish in accordance with Specification A 666. The surface roughness height shall be 50 ± 25 nm [2.0 ± 1.0 μm.] arithmetical average deviation from a mean line. One or both of the panel ends shall be ground to form a 90° angle with the panel surface. Panels showing stains, discolorations, or numerous scratches are not acceptable. New panels should be cleaned before use as described in 10.1, except with ten washes of the final solvent. Between uses, the panels test surface shall be protected from scratches and contamination, and the panels stored at conditions described in 8.1.

**5.3.2** For Procedures E, F, and G, a panel as described in 5.3.1 shall have a 12 mm [0.5 in.] length at one end of the panel bent through an arc of 120° away from the test surface. The radius of the curvature of the finished surface at the bend shall be 1.5 to 3 mm [<sup>1</sup>/<sub>16</sub> to <sup>1</sup>/<sub>8</sub> in.].

<sup>8</sup> These widths correspond to the primary metric (SI) units described in Guide D 5750/D 5750M. These so-called “modular metric” units generally are used throughout the world. If it is desirable to test slightly different widths (for example, 25 of 50 mm) of specimens per 8.4, this should be noted per 12.1.6 and calculations per 11.1 must account for the difference.

<sup>9</sup> Available from Chemsultants International, 9349 Hamilton Drive, Mentor, OH 44061-1118.

5.4 *Roller*, mechanically or hand-operated.<sup>7,9</sup>

5.4.1 A steel roller  $85 \pm 2.5$  mm [ $32.5 \pm 0.5$  in.] in diameter and  $45 \pm 1.5$  mm [1.75 by 0.5 in.] in width, covered with rubber approximately 6 mm [0.25 in.] in thickness, having a Shore scale A durometer hardness of  $80 \pm 5$ . The surface shall be a true cylinder void of any convex or concave deviations. The mass of the roller shall be  $2040 \pm 45$  g [ $4.5 \pm 0.1$  lb].

5.4.2 No part of the apparatus shall increase the mass of the roller during use. The roller shall move either mechanically or by hand at the rate of  $10 \pm 0.4$  mm/s [ $24 \pm 0.5$  in./min].

5.5 *Test Stands and Ancillary Apparatus*:<sup>7,9</sup>

5.5.1 *Procedures A, B, C, D, and H*—A test stand that shall hold the test panel, with tape applied, at an angle of 0–2° with the vertical, so that when the mass is acting on the test specimen, no peel forces will be exerted on the tape.

5.5.2 *Procedures E, G, and F*—A test stand that will support the test panel in a horizontal plane, approximately 300 mm [12 in.] above the work surface.

5.5.3 *Clamp or Hook*, that will allow attachment of the mass to the specimen, distributing the load equally across the tape specimen width.

5.5.4 *Test Masses*:

5.5.4.1 *Procedures A, B, C, D, and H*—The test mass shall be  $1000 \pm 5$  g or other mass as specified. The mass of the clamp or hook described in 5.5.3 shall be included as part of the total mass.

5.5.4.2 *Procedures E, F, and G*—The test mass shall be  $4.5 \pm 0.2$  kg [ $10 \pm 0.5$  lb] or other mass as specified. The mass of the clamp or hook as described in 5.5.3 shall be included in the total mass.

5.5.5 *Timing Systems*:

5.5.5.1 Procedure A, B, C, D, and H to measure the interval in minutes, between the application of the load to the specimen and its separation from the panel.

5.5.5.2 Procedures E, F, and G, a suitable means of measuring the amount of slippage of the tape to 1 mm [ $1/64$  in.] on the panel after the mass has acted for 48 h.

## 6. Reagent Materials

6.1 *Purity of Reagents*—Reagent grade chemicals shall be used in all tests. Other grades may be used, provided it is first ascertained the reagent is of sufficiently high purity to permit its use without lessening the accuracy of the determination.

6.2 *Solvents*:

6.2.1 Any of the following solvents may be used for cleaning.

NOTE 2—Before selecting or using these solvents for cleaning test panels be sure to read and follow all precautions on the chemical Material Safety Data Sheets (MSDS) and consult with Environmental, Health and Safety (EHS) Professionals.

6.2.1.1 Diacetone alcohol nonresidual, technical grade or better.

6.2.1.2 Methanol (95 %).

6.2.1.3 Methyl Ethyl Ketone (MEK).

6.2.1.4 *n*-Heptane.

6.2.1.5 Acetone.

6.2.2 For referee testing, the final cleaning shall be with MEK or acetone.

6.3 *Cleaning Material*, absorbent, surgical gauze, cotton

wool, or tissue. To be suitable, materials must be lint free during use, absorbent, contain no additives that are soluble in the solvents listed in 6.2, and made exclusively from virgin materials.

## 7. Sampling

7.1 *Acceptance Sampling*—Sampling shall be in accordance with Practice D 3715/D 3715M. For Procedures A, E, and H three replicate specimens shall be averaged in accordance with Section 11 for each test result. For Procedures B, C, D, and G five replicate specimens shall be averaged. No single value shall be considered as representative of the roll under test.

7.2 *Sampling for Other Purposes*—The sampling and the number of test specimens depends on the purpose of the testing. Practice E 122 is recommended. It is common to test at least five specimens of a particular tape. Test specimens should be taken from several rolls of a tape and, whenever possible, among several production runs of a tape. Strong conclusions about a specific property of a tape cannot be based on test results of a single unit (roll) of product.

## 8. Test Specimen

8.1 *Removal from Roll*:

8.1.1 Unwind and discard at least three but no more than six outer wraps of tape from the roll before taking specimens for testing.

8.1.2 For Procedures A, E, and H, remove three specimens per sample roll for each test to be performed. For procedures B, C, D, and G remove five specimens per roll for each test to be performed. Remove specimens from freely rotating roll at the rate of 500 to 750 mm/s [20 to 30 in./min]. Where width or other factors causing high adherence to backing make it impossible to remove the specimen at the prescribed rate, remove it at a rate as close to 500 mm [30 in./min] as possible.

8.2 When the tape is wider than the specimen specified in the test procedure, cut the specimen using the specimen cutter described in 5.1 from the center of the of the strip removed from the roll in accordance with 10.1.

8.3 Apply specimen within five min after unwinding.

8.4 *Test Specimen Size*:

8.4.1 Procedures A, B, C, D, and H, the test specimens shall be  $12 \pm 0.05$  mm [ $0.5 \pm 0.003$  in.], or other width, as specified (24 mm [1 in.] may be used) and approximately 150 mm [3 in.] long.

8.4.2 Procedure E, F, and G specimens shall be  $12 \pm 0.05$  mm [ $0.5 \pm 0.016$  in.] in width and approximately 300 mm [12 in.] long.

## 9. Conditioning

9.1 Condition the sample rolls of tape in the standard conditions of  $23 \pm 1^\circ\text{C}$  [ $73.4 \pm 3.6^\circ\text{F}$ ] and 50 %  $\pm 5$  RH. Test at these conditions unless otherwise specified. **Warning**—The tester should know that by prolonged handling of the test panel, heat from the hand is transmitted to the test panel; therefore, just prior to, during and after application of the specimen to the test panel, the panel should be handled as little as possible.

## 10. Procedure

10.1 For Procedures B, C, D, F and G, apply, by means of a double-coated pressure-sensitive tape, a piece of fiberboard

(see 3.3.2, 3.3.3, 3.3.4, 3.3.6 and 3.3.7) wider and longer than the width and length of the test specimen, centered at one end of the test panels (see 5.3.1 and 5.3.2).

NOTE 3—Take care that the fiberboard is applied with the proper side up and with the grain of the paper perpendicular to the long direction of the test panel.

10.2 Procedure A:

10.2.1 Dispense one of the solvents listed in 6.2.1 onto the panel, wiping to dryness with fresh absorbent cleaning material (see 6.3). Repeat for a total of three washes with this solvent. Do not touch cleaned panel surfaces with fingers. **Warning**—All operations with solvents should be conducted in a well-ventilated hood.

NOTE 4—Discard panels showing stains, discoloration, or many scratches. During storage, panels should be protected from damage or contamination.

10.2.2 Center the test specimen on the 50 mm [2 in.] dimension at one end of the test panel and apply, without added pressure, to cover an area exactly 12 by 12 mm [0.5 by 0.5 in.], with tape. It may be desirable to mask the exposed adhesive of the free end of the specimen.

10.2.3 To prevent cutting of the specimen by the end of the panel during roll down, place another panel of the same or slightly lesser thickness and as wide as the test panel, under the free masked end of the specimen, and in contact with the end of the panel prior to roll down. Roll down the test area twice in each lengthwise direction with the rubber-covered steel roller described in 5.4.

10.2.4 Individually prepare each specimen and test within one min.

10.2.5 Place clamp or hook on the free end of the tape specimen, ensuring that the clamp or hook extends completely across the width of the specimen and is aligned to uniformly distribute the load.

10.2.6 Place the test assembly in the test stand so that the free end of the test specimen is vertical, ensuring that no peel forces act on the specimen.

10.2.7 Apply the 1000 g mass to the clamp or hook gently so as to cause no shear impact force on the tape specimen. Record the time elapse in which the tape specimen has separated completely from the test panel (see Fig. 1).

10.3 Procedures B, C, and D—Conduct these tests as described in 10.2, except the test panel shall be covered with fiberboard as described in 10.1.

10.4 Procedure E:

10.4.1 Clean, as described in 10.2.1, a test panel described in 5.3.1.

10.4.2 Apply one end of the specimen, about 100 mm [4 in.] in length, adhesive side down, to the longitudinal surface of the test panel. The tape must be at a true right angle to the bent edge of the panel. Allow the remaining 200 mm [8 in.] to extend over and beyond the bend edge of the panel.

10.4.3 Using a square, cut across, and through the width of the tape specimen 75 mm [3 in.] back from the front of bend in the horizontal plane of the test panel surface.

10.4.4 Roll twice, once in each lengthwise direction using the rubber covered steel roller described in 5.4.

10.4.5 Place the clamp or hook on the free end of the

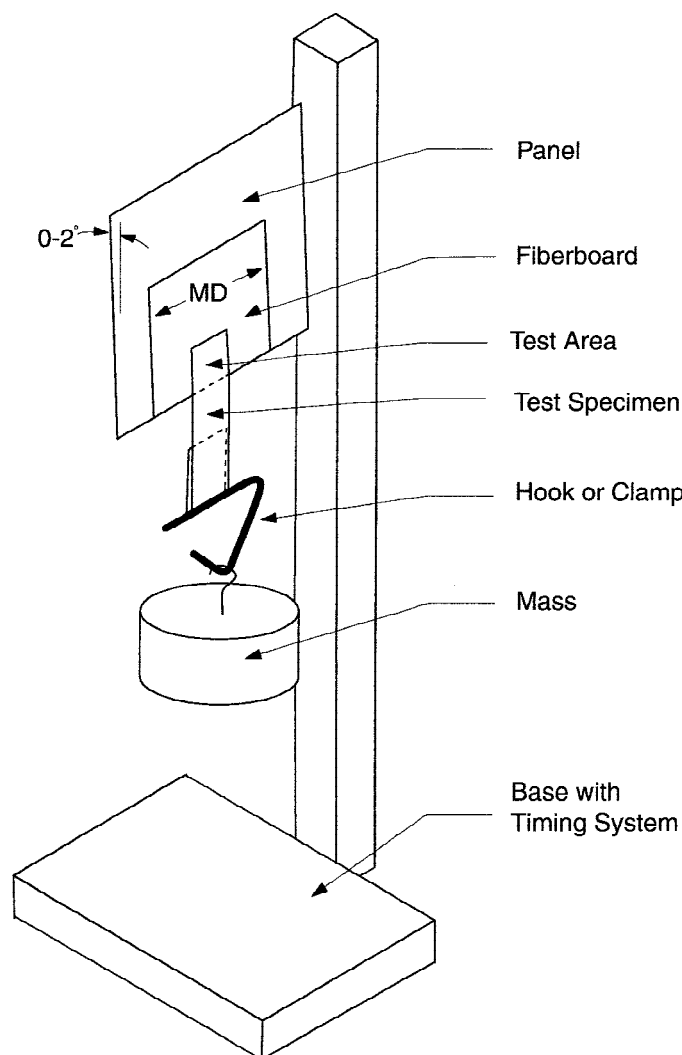

FIG. 1 Sketch of Typical Shear Adhesions Tester for Procedures B, C, and D. (For Procedures A and H, substitute steel panel instead of fiberboard.)

specimen, ensuring that it extends completely across the width of the specimen, and is aligned to distribute the load uniformly.

10.4.6 Place the test assembly in the test stand so that the panel is horizontal, tape side up, and the free end of the test specimen is vertical. Apply the 4.5-kg [10-lb] mass to the clamp or hook gently so as to cause no impact force on the specimen (see Fig. 2).

10.4.7 At the end of 48 h under load, examine the specimen for evidence of slippage. Measure any slippage that has occurred to the nearest 1 mm [ $1/32$  in.].

10.5 Procedure F and G—Conduct these tests as described in 10.4, except the test panels shall be covered with fiberboard as described in 10.1.

10.6 Procedure H:

10.6.1 Prepare test specimens as described in 10.2.1-10.2.5.

10.6.2 Place the test stand, with specimen in place, in an oven maintained at 50°C [120°F].

10.6.3 Allow to condition at 50°C [120°F], for ten min, then apply 1000-g mass to the clamp or hook gently so as to cause no shear impact force on the tape specimen. Record the time



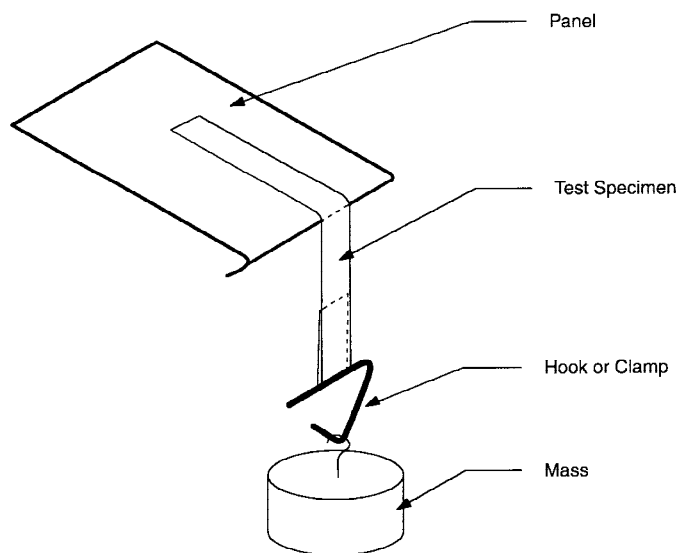

FIG. 2 Sketch of Typical Shear Adhesion Tester for Procedure E. (For Procedures F and G, substitute a fiberboard surface.)

elapse in which the tape specimen has completely separated from the test panel.

### 11. Calculation

#### 11.1 Acceptance Sampling:

11.1.1 *Procedures A, B, C, D, and H*—To determine the test results for each roll of tape, convert each of the test results (time to failure) to its common or natural logarithm. Obtain the arithmetic mean of all logarithms and then convert back to time by obtaining the appropriate antilogarithm. This gives the test results for the roll of tape under consideration in the sampling plan.

11.1.2 *Procedures E, F and G*—It is common to interpret the results of these test methods as passing or failing a preset acceptance criterion.

11.2 *Other Purposes*—Convert the test results (time to failure) from each specimen to its common or natural logarithm. Conduct an analysis of the logarithm of the data to determine the desired descriptive or comparative statistics. The resulting means and confidence intervals may be converted back to the original time units by obtaining the appropriate antilogarithm.

### 12. Report

12.1 Report the following information:

12.1.1 Statement including which test procedure was used and indicating any deviation from the procedure as written,

12.1.2 Identify source of each roll,

12.1.3 For Procedures A, B, C, D, and H the time for the tape to separate completely from the panel. For Procedures E, F, and G the amount of slippage in mm [in.] to the nearest mm [ $\frac{1}{64}$  in.],

12.1.4 Dwell time, if other than one min,

12.1.5 Test specimen size for Procedures A, B, C, D, and H if other than 12 by 12 mm [0.5 by 0.5 in.]. Width of specimen for Procedures E, F, and G if other than 12 mm [0.5 in.],

12.1.6 Conditioning if other than 23°C [73.4°F] or 50 % RH,

12.1.7 Test temperatures for Procedures A, B, C, D, and G if other than 23°C [73.4°F] and test temperature for Procedure H, if other than 50°C [120°F],

12.1.8 *Mode of Failure – Cohesion (Cohesive strength, internal bond)*—The ability of the adhesive to resist splitting. Good cohesion is necessary for clean removal. Adhesion is a bond produced between a pressure-sensitive tape adhesive and a surface for Procedures A, B, C, D, and H; and,

12.1.9 Fiberboard substrate, if Procedure D is used.

### 13. Precision and Bias

13.1 *Procedures A, B, C, and D*—Repeatability (within laboratory variability) information is available from one laboratory; several types of tape were evaluated using time to failure in minutes converted to natural logarithm for analysis. Examples of averages and with-in-roll standard deviations (including test error) are as follows:

| Tape | X    | Converted X, min. | Within Roll |
|------|------|-------------------|-------------|
| A    | 8.74 | 6248              | 0.32        |
| B    | 8.27 | 3905              | 0.23        |
| C    | 2.43 | 114               | 0.27        |
| D    | 6.50 | 665               | 0.45        |
| E    | 5.98 | 395               | 0.82        |

13.1.1 The remaining components of variance are expected to be similar to those for Procedure H. The between roll standard deviation and the residual (including within roll) standard deviations will vary, depending on the tape type and the manufacturer.

13.1.2 *Procedures E, F, and G*—No statement is made about the precision of the procedures since results merely state whether there is conformance to specified criteria for success.

13.1.3 *Procedure H*—An interlaboratory evaluation of two types of pressure-sensitive tapes by three laboratories has been conducted for Procedure H. The results are available.<sup>10</sup> It is based on an evaluation using lognormal distribution; the times to failure in minutes were converted to their natural (base *e*) logarithms for analysis. The tapes tested in this study had a grand mean of 1.2, which converts to 3.3 min. The components of the variance for the following factors were estimated: between operator in a laboratory, between rolls of tape, and residual (including test error and within roll variation).

13.1.3.1 A summary of the pooled standard deviation is as follows:

|                      |       |
|----------------------|-------|
| Between laboratories | 0.46  |
| Between testers      | 0.247 |
| Between rolls        | 0.185 |
| Residual             | 0.411 |

13.1.3.2 These components may be combined in several ways to obtain the desired repeatability (within laboratory) and reproducibility (between laboratory) estimates of precision. One company reports that, with care, the between laboratory standard deviation and the residual (including within roll) standard deviation may be higher or lower than reported here, depending on the tape type and manufacturer.

13.2 *Bias*—No measurement of bias is possible with this

<sup>10</sup> Supporting data are available from ASTM Headquarters. Request RR: D-10-1002, Report 2.

test method because an accepted reference or referee value is not available.

#### **14. Keywords**

14.1 filament-reinforced tape; pressure-sensitive tape; shear adhesion

*ASTM International takes no position respecting the validity of any patent rights asserted in connection with any item mentioned in this standard. Users of this standard are expressly advised that determination of the validity of any such patent rights, and the risk of infringement of such rights, are entirely their own responsibility.*

*This standard is subject to revision at any time by the responsible technical committee and must be reviewed every five years and if not revised, either reapproved or withdrawn. Your comments are invited either for revision of this standard or for additional standards and should be addressed to ASTM International Headquarters. Your comments will receive careful consideration at a meeting of the responsible technical committee, which you may attend. If you feel that your comments have not received a fair hearing you should make your views known to the ASTM Committee on Standards, at the address shown below.*

*This standard is copyrighted by ASTM International, 100 Barr Harbor Drive, PO Box C700, West Conshohocken, PA 19428-2959, United States. Individual reprints (single or multiple copies) of this standard may be obtained by contacting ASTM at the above address or at 610-832-9585 (phone), 610-832-9555 (fax), or [service@astm.org](mailto:service@astm.org) (e-mail); or through the ASTM website ([www.astm.org](http://www.astm.org)).*