



# Standard Test Method for Misting Properties of Lubricating Fluids<sup>1</sup>

This standard is issued under the fixed designation D 3705; the number immediately following the designation indicates the year of original adoption or, in the case of revision, the year of last revision. A number in parentheses indicates the year of last reapproval. A superscript epsilon ( $\epsilon$ ) indicates an editorial change since the last revision or reapproval.

<sup>ε1</sup> NOTE—Warning notes were editorially moved into the standard text in June 2003.

## 1. Scope

1.1 This test method covers the determination of the misting characteristics of lubricating fluids.

NOTE 1—This test method should not be used to evaluate fluids containing solid additives such as graphite.

1.2 *This standard does not purport to address all of the safety concerns, if any, associated with its use. It is the responsibility of the user of this standard to establish appropriate safety and health practices and determine the applicability of regulatory limitations prior to use.* For specific warning statements, see Sections 6 and 7.

## 2. Referenced Documents

### 2.1 ASTM Standards:

D 91 Test Method for Precipitation Number of Lubricating Oils<sup>2</sup>

D 235 Specification for Mineral Spirits (Petroleum Spirits) (Hydrocarbon Dry Cleaning Solvent)<sup>3</sup>

## 3. Summary of Test Method

3.1 The mist generator is charged with oil and installed in the mist system. The unit is operated for 19 h; the mist generator, line condensate bottles, and reclassified oil collector are weighed before and after the test. The output from the generator and percentages of reclassified oil, line condensate, and stray mist are determined from changes in weight.

NOTE 2—Line condensate is the commonly accepted term used to describe the oil that coalesces in the mist distribution lines. In this test, the oil that coalesces in the 38-mm (1½ -in.) tubing and the diagonal 19-mm (¾ -in.) tubing is collected and weighed as line condensate. Oil that coalesces in the vertical 19-mm (¾ -in.) tubing becomes part of the reclassified oil.

<sup>1</sup> This test method is under the jurisdiction of ASTM Committee D02 on Petroleum Products and Lubricants and is the direct responsibility of Subcommittee D02.L0 on Industrial Lubricants.

Current edition approved May 10, 2003. Published July 2003. Originally approved in 1978. Last previous edition approved in 1998 as D 3705–86 (1998).

<sup>2</sup> *Annual Book of ASTM Standards*, Vol 05.01.

<sup>3</sup> *Annual Book of ASTM Standards*, Vol 06.04.

## 4. Significance and Use

4.1 This test provides a guide for evaluating the misting characteristics of oils for use in industrial mist lubrication systems. The degree of correlation between this test and service performance has not been fully determined.

## 5. Apparatus

5.1 The basic system consists of the following:

5.1.1 *Oil Mist Generator*,<sup>4,5</sup> with special ASTM-ASLE mist head assembly.

5.1.2 *Air Temperature Regulator*.<sup>5,6</sup>

5.1.3 *Mist Distribution Manifold*, as shown in Fig. 1.

5.1.4 *Mist Reclassifier Fitting*, as shown in Fig. 2.

5.1.5 *Reclassified Oil Collector*, as shown in Fig. 3.

5.2 *Balance*, 20-kg capacity open pan, with 1-g sensitivity.

5.3 *Air Supply*, from a source capable of maintaining an air flow rate up to 2 dm<sup>3</sup>/s. The air should be dry, oil-free, and filtered through a 1- $\mu$ m filter.

NOTE 3—The oil mist generator head and mist reclassifier fitting are available from the Alemite Co. Orders should specify Special ASTM-ASLE mist head and reclassifier fitting.

## 6. Reagents

6.1 *Stoddard Solvent*, as specified in Specification D 235 (Type 1). (**Warning**—Flammable.)

6.2 *Precipitation Naphtha*, as specified in Test Method D 91. (**Warning**—Flammable.)

## 7. Preparation of Apparatus

7.1 Thorough cleaning of the apparatus with solvent is required prior to initiating a test on a new oil. For a duplicate

<sup>4</sup> The sole source of supply of Alemite No. 383802-4 known to the committee at this time is Alemite Co., Stewart Warner, 1826 West Diversey Parkway, Chicago, IL 60614.

<sup>5</sup> If you are aware of alternative suppliers, please provide this information to ASTM International Headquarters. Your comments will receive careful consideration at a meeting of the responsible technical committee<sup>1</sup>, which you may attend.

<sup>6</sup> The sole source of supply of Alemite thermo-aire unit No. 383808-A4 known to the committee at this time is Alemite Co., Stewart Warner, 1826 West Diversey Parkway, Chicago, IL 60614.

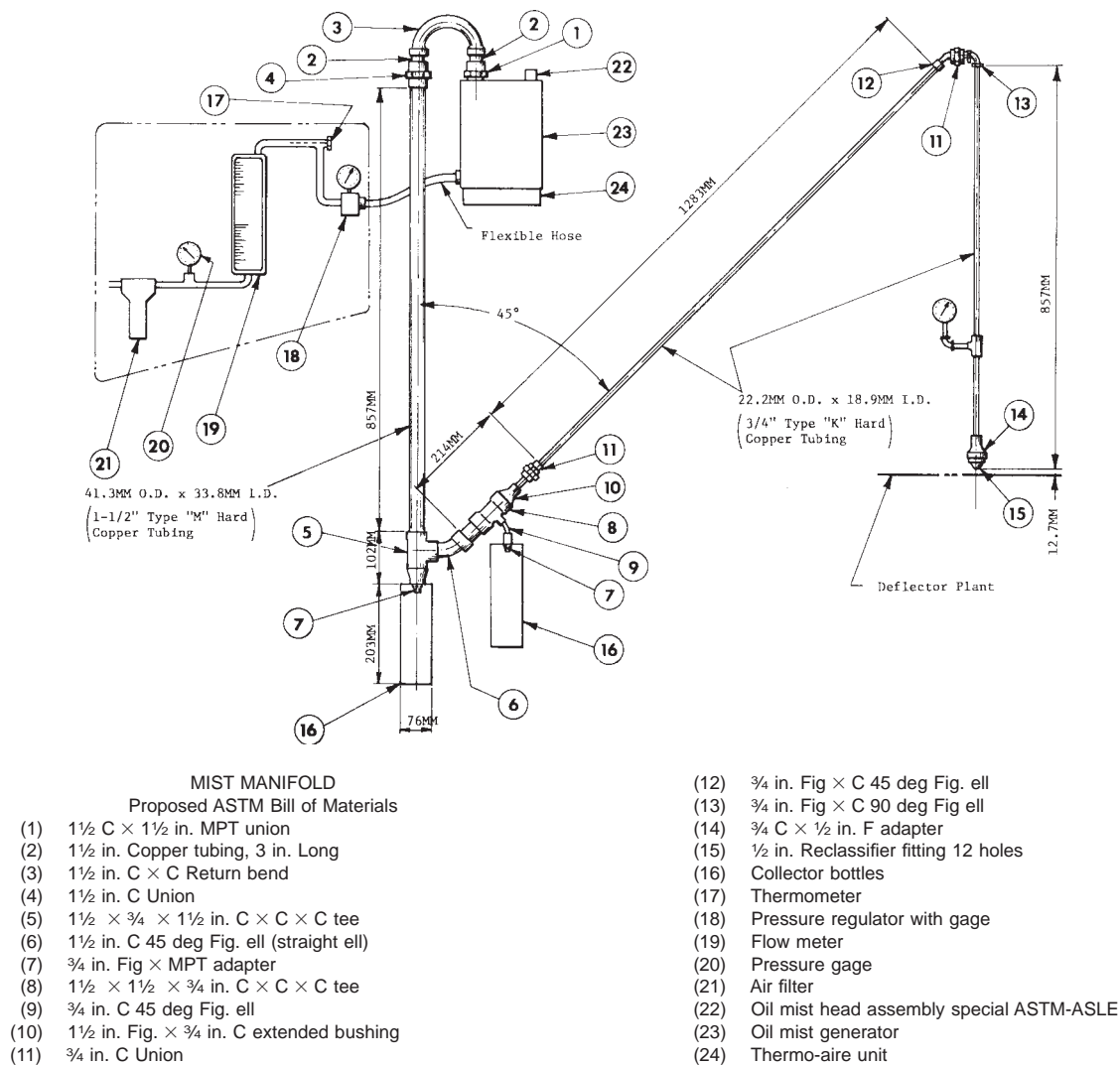

FIG. 1 Mist Test Apparatus

test on the same oil, the mist generator should be thoroughly drained but the apparatus need not be cleaned with solvent.

7.2 Drain the oil thoroughly and rinse the generator with Stoddard solvent. (**Warning**—Combustible. Vapor harmful.)

7.3 Charge the generator with 2 L of clean Stoddard solvent and mist the Stoddard solvent through the manifold for 30 min. (**Warning**—Do not use the air heater while misting the Stoddard solvent.)

7.4 Drain the Stoddard solvent from the generator, rinse the generator with naphtha, and blow dry with compressed air. (**Warning**—Extremely flammable. Harmful if inhaled. Vapors may cause flash fire.)

7.5 Disconnect the mist head and remove the oil adjustment screw; rinse the head and screw with naphtha and blow dry.

7.6 Remove the reclassifier fitting and rinse it with naphtha; examine the orifices for deposits or buildup. If necessary, the orifices may be cleaned with a fine pipe cleaner.

## 8. Procedure

### 8.1 Break-In Period:

8.1.1 Charge the mist generator with  $4 \pm 0.1$  L of test oil. Assemble the test apparatus.

8.1.2 Turn the oil flow adjusting screw clockwise to a fully closed position and then open the screw by turning it counterclockwise to a full open position.

8.1.3 Open the air regulator until a pressure of 37 millibars (37 KPa) is obtained on the manifold gage.

8.1.4 Activate the oil heater and inlet air heater and adjust both to  $40 \pm 1^\circ\text{C}$ .

8.1.5 Allow the unit to run for 1 h to stabilize.

NOTE 4—The full open position for the oil flow adjusting screw, that is, the position beyond which further opening of the adjusting screw does not increase oil output from the mist generator, should be determined for each mist test unit. The full open position on most test units is attained by turning the adjusting screw counterclockwise 2-1/2 turns from the fully closed position.

### 8.2 Test Start-Up:

8.2.1 Following the 1-h break-in, deactivate the air and oil heaters and turn off the air supply.

**ASTM D 3705 – 86 (2003)€1**

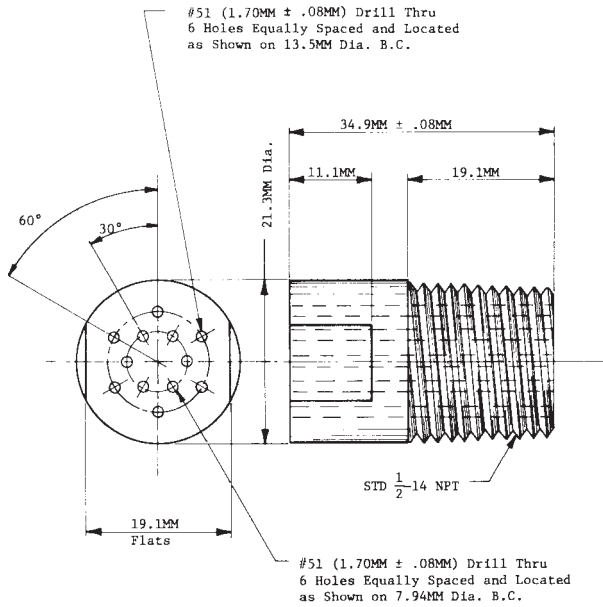

Mat'l. For (1)

Bar 22.2MM Dia. x 34.9MM Long  
Brass

**FIG. 2 Mist Reclassifier Fitting**

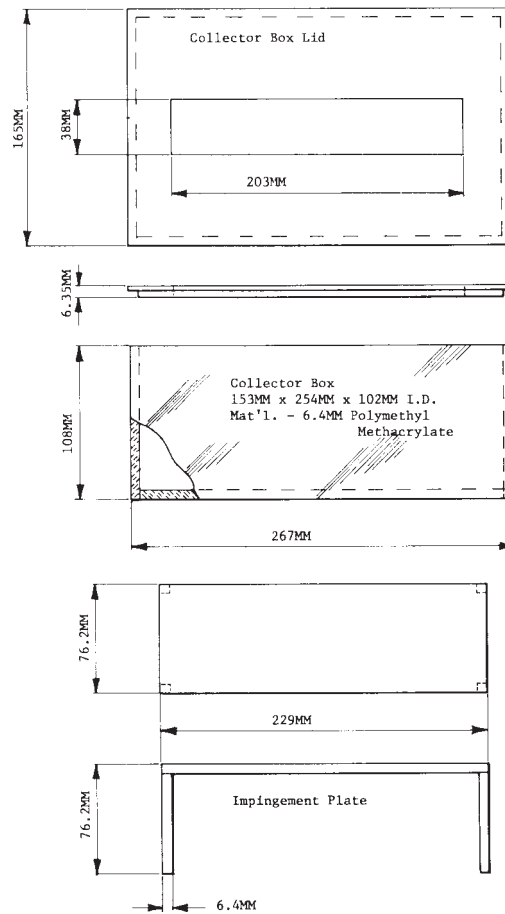

**FIG. 3 Reclassified Oil Collector**

8.2.2 Disconnect and weigh the mist generator ( $W_1$ ) and install clean, tared line condensate bottles ( $LC_1$ ) and reclassified oil collector ( $RC_1$ ).

8.2.3 Reassemble the apparatus. Turn on the inlet air and activate the air and oil heaters to start the test.

8.2.4 Record the air flow rate in  $\text{dm}^3/\text{s}$ .

8.2.5 Check the inlet air temperature, oil reservoir temperature and manifold temperature. Make adjustments, if necessary, 30 min after starting the test to bring the manifold pressure to  $37 \pm 1$  millibars, ( $3.7 \pm 0.1$  KPa) and the inlet air temperature to  $40^\circ\text{C}$ .

8.2.6 At the end of the 19-h test, deactivate the heaters and turn off the air supply. Disconnect and weigh the mist generator ( $W_2$ ), line condensate bottles ( $LC_2$ ), and reclassified oil collector ( $RC_2$ ) within 15 min.

## 9. Calculation and Report

9.1 Calculate and report the oil output from the mist generator after break-in in grams per hour as follows:

$$\text{oil output} = \frac{W_1 - W_2}{19} \quad (1)$$

where:

$W_1$  = weight of the mist generator at the start of the test, g,  
and

$W_2$  = weight of the mist generator after 19 h, g.

9.2 Calculate and report the percent of reclassified oil as follows:

$$\% \text{ reclassified oil} = \frac{RC_2 - RC_1}{W_1 - W_2} \times 100 \quad (2)$$

where:

$RC_1$  = weight of the reclassified oil collector at the start of the test, g,

$RC_2$  = weight of the reclassified oil collector at the end of the test, g.

9.3 Calculate and report the percent of line condensate as follows:

$$\% \text{ line condensate} = \frac{LC_2 - LC_1}{W_1 - W_2} \times 100 \quad (3)$$

where:

$LC_1$  = weight of the line condensate bottles at the start of the test, and

$LC_2$  = weight of the line condensate bottles at the end of the test.

9.4 Calculate and report the percent of stray mist as follows:

$$\% \text{ stray mist} = 100 - (\% \text{ reclassified oil} + \% \text{ line condensate}) \quad (4)$$

NOTE 5—For design considerations, it may be desirable to calculate the output oil mist density or effective oil mist density, or both. These calculations are made as follows:

$$\text{Oil output mist density, mg/m}^3 = \frac{\text{oil output (g/h)} \times 1000}{\text{air flow rate (dm}^3/\text{s)} \times 3.6} \quad (5)$$

Effective oil mist density,  $\text{mg/m}^3$  (6)

$$= \frac{\text{reclassified oil (RC}_2 - \text{RC}_1) \times 1000}{\text{air flow rate (dm}^3/\text{s)} \times 68.4}$$

## 10. Precision and Bias <sup>7</sup>

10.1 The precision of this test method as determined by statistical examination of interlaboratory results is as follows:

10.1.1 *Repeatability*—The difference between successive results obtained by the same operator with the same apparatus under constant operating conditions on identical test material would, in the long run, in the normal and correct operation of the test method, exceed the following values only in one case in twenty:

Oil output, g/h	8 %
Percent reclassified oil	6 %
Percent line condensate	22 %

10.1.2 *Reproducibility*—The difference between two single and independent results obtained by different operators working in different laboratories on identical test material would, in the long run, exceed the following values only in one case in twenty:

Oil output, g/h	41 %
Percent reclassified oil	57 %
Percent line condensate	73 %

10.2 *Bias*—The procedure in this test method has no bias because the values of Oil Output, percent Reclassified Oil, and percent Line Condensate can be defined only in terms of a test method.

NOTE 6—The percent of stray mist is obtained by calculation rather than by a direct determination. Therefore, no precision data are included for percent of stray mist.

<sup>7</sup> Supporting data (derived from results of the cooperative tests on oils L-II-3-M, N, O, P, Q, R, S, T, U, V, W, and X) have been filed at ASTM International Headquarters and may be obtained by requesting Research Report RR: D02-1056.

APPENDIX

(Nonmandatory Information)

**X1. METHOD FOR HANDLING STRAY MIST**

X1.1 Fig. X1.1 shows a container that has been found satisfactory for handling the stray mist generated during the test.

X1.2 The stray mist is sucked from the container through a filter-coalescer unit which removes approximately 99 % of the oil. The suction is obtained using an air jet exhauster; the exhaust can be fed into the laboratory exhaust system.<sup>5,8</sup>

X1.3 The exhaust system should be started after a mist test has been initiated and must not affect the manifold pressure. If a decrease in manifold pressure is noted when the exhaust system is started, the vent hole should be enlarged.

X1.4 The baffles must be included as an integral part of the container to prevent air flow directly across the top of the reclassified oil collector.

---

<sup>8</sup> The sole source of supply of the Figure 431 1-in. jet exhauster known to the committee at this time is Schulte and Koerting, State Rd and Traylor Ave., Cornwells Heights, PA 19020.

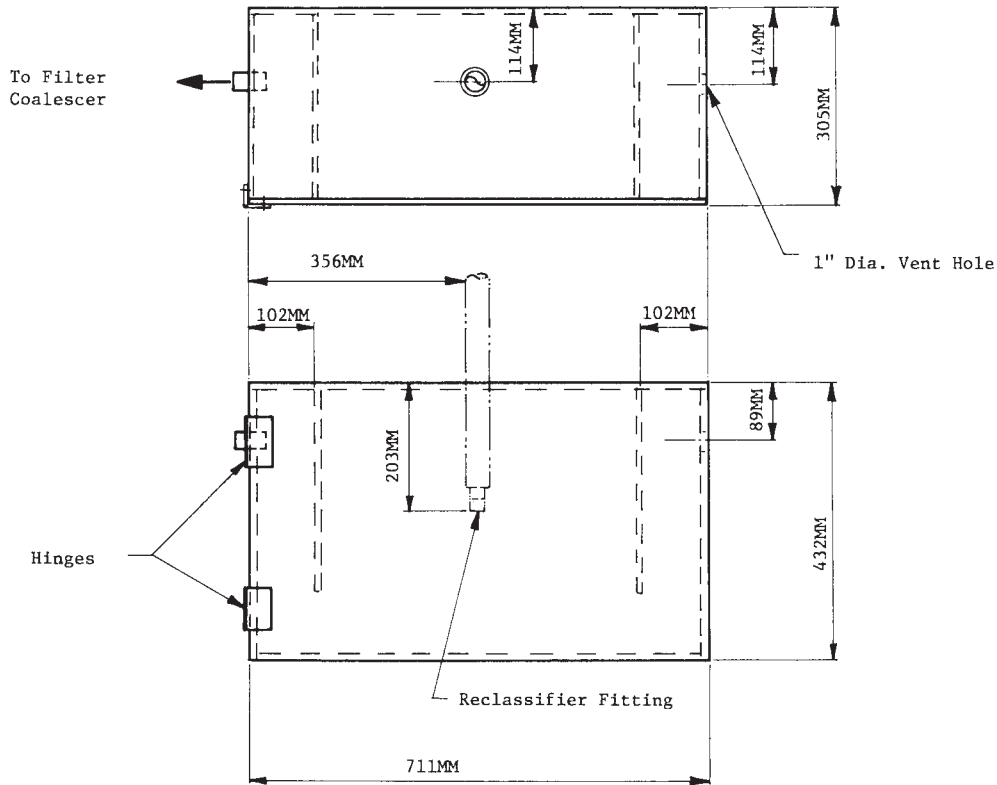

**Mat'l.:**

- 6.4MM Plywood (1/4")
- 6.4MM Polymethyl Methacrylate

**FIG. X1.1 Apparatus For Removing Stray Mist**

ASTM International takes no position respecting the validity of any patent rights asserted in connection with any item mentioned in this standard. Users of this standard are expressly advised that determination of the validity of any such patent rights, and the risk of infringement of such rights, are entirely their own responsibility.

This standard is subject to revision at any time by the responsible technical committee and must be reviewed every five years and if not revised, either reapproved or withdrawn. Your comments are invited either for revision of this standard or for additional standards and should be addressed to ASTM International Headquarters. Your comments will receive careful consideration at a meeting of the responsible technical committee, which you may attend. If you feel that your comments have not received a fair hearing you should make your views known to the ASTM Committee on Standards, at the address shown below.

This standard is copyrighted by ASTM International, 100 Barr Harbor Drive, PO Box C700, West Conshohocken, PA 19428-2959, United States. Individual reprints (single or multiple copies) of this standard may be obtained by contacting ASTM at the above address or at 610-832-9585 (phone), 610-832-9555 (fax), or service@astm.org (e-mail); or through the ASTM website (www.astm.org).