



# Standard Test Method for Positive Pressure Fire Tests of Window Assemblies<sup>1</sup>

This standard is issued under the fixed designation E 2010; the number immediately following the designation indicates the year of original adoption or, in the case of revision, the year of last revision. A number in parentheses indicates the year of last approval. A superscript epsilon ( $\epsilon$ ) indicates an editorial change since the last revision or reapproval.

## INTRODUCTION

This fire test response standard replaces test method E 163, which was formerly under the jurisdiction of Committee E05 on Fire Standards. Test method E 163 was withdrawn on January 1, 1995 in accordance with section 10.5.3.1 of the Regulations Governing ASTM Technical Committees, which requires that standards shall be updated by the end of the eighth year since last approval date.

### 1. Scope

1.1 This test method covers fire-test-response applicable to window assemblies, including glass block and other light transmitting assemblies, for use in walls or partitions to retard the passage of fire (see Appendix X1).

1.2 This fire-test-response test method will determine the ability of window assemblies, including glass block and other light transmitting assemblies, to function as a fire barrier during a standard fire endurance test. Such tests shall not be construed as determining suitability of window assemblies for continued use after fire exposure (see Appendix X1.2).

1.3 This fire-test-response test method is intended to evaluate the ability of window assemblies, including glass block or other light transmitting assemblies, to remain in a wall or partition during a predetermined fire test exposure, which is then followed by the application of a hose stream (see Appendix X1.3).

1.4 The fire exposure is not necessarily representative of all fire conditions, which normally vary with changes in the amount, nature and distribution of fire loading, ventilation, compartment size and configuration, and heat sink characteristics of the compartment. It does, however, provide a relative measure of fire performance of window assemblies under these specified fire exposure conditions.

1.5 The hose stream test used in this test method is not designed to be representative of an actual hose stream used by a fire department during fire suppression efforts.

1.6 Any variation from the construction or conditions that are tested will possibly change the performance characteristics of the assembly.

1.7 This fire-test-response standard does not provide the following:

1.7.1 The fire endurance of window assemblies in walls or partitions constructed of materials other than those tested.

1.7.2 A temperature measurement on the unexposed surface of the window assembly.

1.7.3 A measurement of smoke or products of combustion that pass through the window assembly.

1.7.4 A measurement of smoke, toxic gases, or other products of combustion generated by the window assembly.

NOTE 1—The information in 1.7.3 and 1.7.4 may be important in determining the fire hazard or fire risk of window assemblies under actual fire conditions. This information may be determined by other suitable fire test methods. For example, flame spread and smoke development may be determined by Test Method E 84.

1.8 This fire-test-response test method permits through-openings, that are created by cracking, separation, or loss of glazing material, provided they do not exceed specified limits.

1.9 The values stated in either inch-pound or SI units are to be regarded separately as the standard. Within the text, the SI units are shown in brackets. The values stated in each system are not exact equivalents; therefore, each system shall be used independently of the other.

NOTE 2—Combining values from the two systems may result in non-conformance to this test method.

1.10 *This standard does not purport to address all of the safety concerns, if any, associated with its use. It is the responsibility of the user of this standard to establish appropriate safety and health practices and determine the applicability of regulatory limitations prior to use.*

1.11 *This standard is used to measure and describe the response of materials, products, or assemblies to heat and flame under controlled conditions, but does not by itself incorporate all factors required for fire hazard or fire risk*

<sup>1</sup> This test method is under the jurisdiction of ASTM Committee E05 on Fire Standards and is the direct responsibility of Subcommittee E05.11 on Fire Endurance.

Current edition approved October 10, 2001. Published January 2002. Originally published as E 2010-99. Last previous edition E 2010-99.

assessment of the materials, products, or assemblies under actual fire conditions.

1.12 The text of this test method references notes and footnotes which provide explanatory material. These notes and footnotes (excluding those in tables and figures) shall not be considered as requirements of this test method.

**2. Referenced Documents**

2.1 *ASTM Standards:*

E 119 Tests Methods for Fire Tests of Building Construction and Materials<sup>2</sup>

E 163 Test Methods of Fire Tests of Window Assemblies<sup>3</sup>

E 176 Terminology of Fire Standards<sup>2</sup>

E 631 Terminology of Building Constructions<sup>2</sup>

2.2 *UL Standard:*

UL 385 Standard for Play Pipes for Water Supply Testing in Fire-Protection Service, 1993<sup>4</sup>

**3. Terminology**

3.1 *Definitions*—For the purpose of this test method, the definitions given in Terminology E 176 and Terminology E 631, together with the following, shall apply:

3.1.1 *fire window assembly, n*—a window or glass block configuration, intended for use in walls or partitions, for which a fire endurance rating has been determined in accordance with this fire-test-response standard.

3.1.2 *glass block assembly, n*—a light transmitting configuration constructed of glass block held together with mortar or other suitable materials.

3.1.3 *glazing material, n*—transparent or translucent material used in fire window assemblies.

3.1.4 *light flame, n*—a flame approximately 6 in. (152 mm) long.

3.1.5 *through-opening, n*—a uninterrupted hole in the test assembly that is seen from the unexposed side when viewing the suspected hole from a position perpendicular to the plane of the test assembly.

3.1.6 *window assembly, n*—an integrally fabricated unit containing a glazed light(s) placed in an opening in a wall or partition and that is intended primarily for the transmission of light, or light and air, and not primarily as an entrance or exit.

**4. Summary of Test Method**

4.1 This fire-test-response test method describes the following test sequence and procedure.

4.1.1 A window assembly is exposed to a standard fire exposure, controlled to achieve specified temperatures and pressures throughout a specified time period.

4.1.2 After the fire endurance test, the window assembly is subjected to a hose stream test.

**5. Significance and Use**

5.1 In this fire-test-response test method, the test specimens are subjected to one or more specific sets of laboratory test

conditions. When different test conditions are substituted or the end-use conditions are changed, it is not always possible by, or from, this test method to predict changes to the characteristics measured. Therefore, the results are valid only for the exposure conditions described in this test method.

5.2 This fire-test-response standard determines the fire endurance, in elapsed min, during the test exposure and develops data to enable regulatory bodies to determine the suitability of window assemblies for use in locations where fire resistance of a specified duration is required.

5.3 The data is not intended to be used to describe or appraise the fire hazard or fire risk of materials, products, or assemblies under actual fire conditions.

5.4 This fire-test-response test method requires that observations be made and recorded relevant to the passage of flame. This data is too imprecise for quality control purposes.

5.5 This fire-test-response test method uses a hose stream test to assess the durability of the window assembly relevant to the passage of a stream of water. This data is too imprecise for quality control purposes.

**6. Apparatus**

6.1 *Furnace and Test Frame:*

6.1.1 The furnace construction shall be suitable to meet the requirements of the fire test protocol. An example of the furnace and test frame is illustrated in Fig. 1 (see Appendix X1.4).

6.1.2 The height and width of the furnace opening shall be greater than the test assembly’s corresponding dimension.

6.1.3 The furnace shall be heated with burners that are fired using either natural gas or liquefied petroleum gases. The burners shall:

6.1.3.1 Have a controllable heat output.

6.1.3.2 Be able to expose the test sample to the uniform heating of the standard time-temperature curve.

6.2 *Pressure-Sensing Probes:*

6.2.1 The pressure-sensing probes shall be either:

6.2.1.1 A T-shaped sensor as shown in Fig. 2, or

6.2.1.2 A tube sensor as shown in Fig. 3.

6.3 *Differential Pressure Measurement Instruments:*

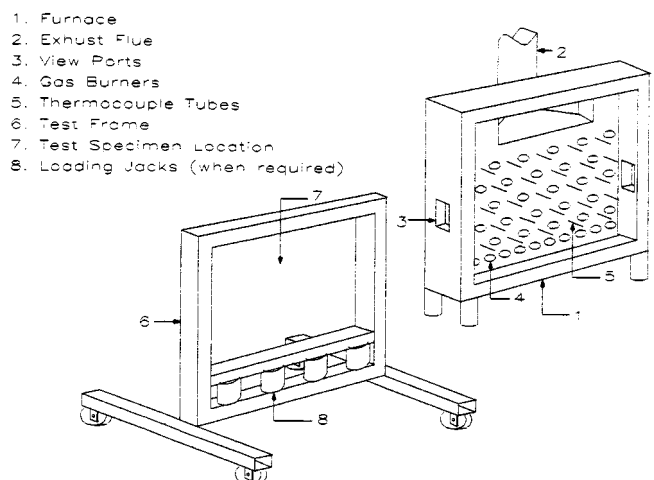

FIG. 1 Furnace and Test Frame

<sup>2</sup> Annual Book of Standards, Vol 04.07.

<sup>3</sup> Discontinued; see 1994 Annual Book of Standards, Vol 04.07.

<sup>4</sup> Underwriters Laboratories, 333 Pfingsten Road, Northbrook, IL 60062.

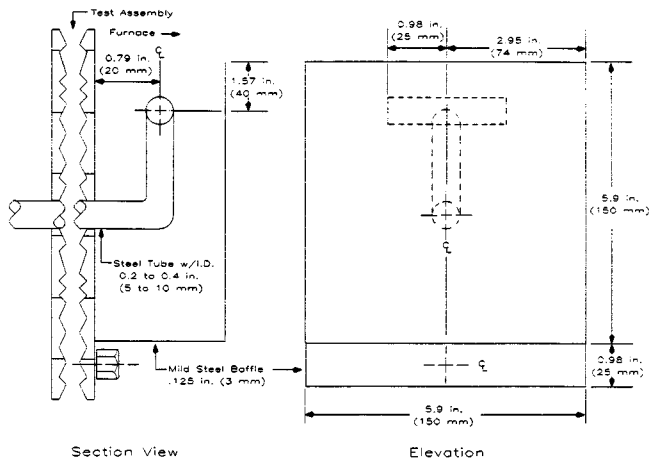

FIG. 2 T-Shaped Sensor

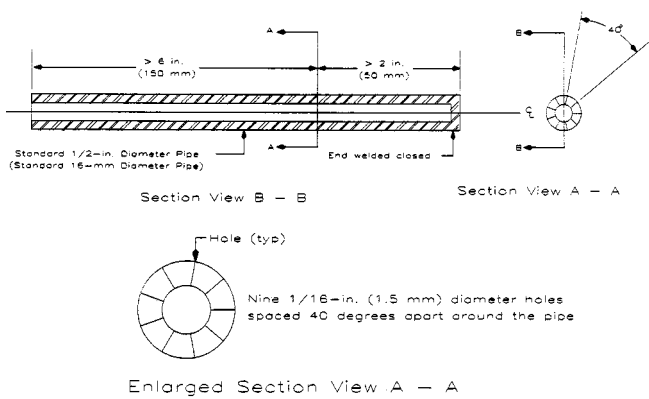

FIG. 3 Tube Sensor

6.3.1 The differential pressure measurement instrument shall be:

6.3.1.1 A manometer or equivalent transducer, and

6.3.1.2 Capable of reading in graduated increments of no greater than 0.01 in. H<sub>2</sub>O (2.5 Pa) with a precision of not less than ± 0.005 in. H<sub>2</sub>O (± 1.25 Pa).

6.4 *Hose Stream Delivery System:*

6.4.1 The hose stream delivery system shall consist of:

6.4.1.1 A standard 2-1/2 in. (64 mm) diameter hose attached to a national standard play pipe as described in UL 385.

6.4.1.2 The play pipe shall have an overall length of 30 ± 0.25 in. (762 ± 6 mm) and shall be equipped with a standard 1-1/8 in. (28.5 mm) discharge tip of the standard-taper-smooth-bore pattern without shoulder at the orifice.

6.4.1.3 The play pipe shall be fitted with a standard 2-1/2 in. (64 mm) inside dimension by 6 in. (153 mm) long nipple mounted between the hose and the base of the play pipe.

6.4.1.4 A pressure tap for measuring the water pressure at the base of the nozzle shall be normal to the surface of the nipple, shall be centered in its length, and shall not protrude into the water stream.

6.4.1.5 A suitable pressure gauge capable of reading a minimum of 0–50 psi (0–344.8 kPa) and graduated into no greater than 2 psi (13.8 kPa) increments shall be used to measure the water pressure.

6.5 *Furnace Thermocouples:*

6.5.1 The furnace thermocouples shall:

6.5.1.1 Be protected by sealed porcelain tubes having a nominal 3/4 in. (19 mm) outside diameter and 1/8 in. (3 mm) wall thickness, or, as an alternative, in the case of base metal thermocouples, protected by a standard 1/2 in. (13 mm) diameter wrought steel or wrought iron pipe of standard weight, and

6.5.1.2 Have a time constant between the range of 6.0 to 7.2 min while encased in the tubes described in 6.5.1.1.

NOTE 3—A typical thermocouple assembly meeting these time constant requirements may be fabricated by fusion-welding the twisted ends of No. 18 gage Chromel-Alumel wires, mounting the leads in porcelain insulators and inserting the assembly so the thermocouple bed is 0.5 in. (25 mm) from the sealed end of the standard weight nominal 1/2 in. iron, steel, or Inconel<sup>5</sup> pipe. The time constant for this and for several other thermocouple assemblies was measured in 1976. The time constant may also be calculated from knowledge of its physical and thermal properties.<sup>6</sup>

6.5.2 Other types of protection tubes or pyrometers are permitted to be used provided that under test conditions they give the same indications as those of 6.5.1 within the limit of accuracy that applies for furnace-temperature measurements.

## 7. Time-Temperature Curve

7.1 The fire exposure of window assemblies shall be controlled to conform to the applicable portion of the standard time-temperature curve shown in Fig. 4 (see X2.5).

7.1.1 For a more detailed definition of the time-temperature curve, refer to Table 1.

<sup>5</sup> Inconel is a registered trade name of INCO Alloys, Inc., 3800 Riverside Dr., Huntington, WV 25720.

<sup>6</sup> Supporting data is available from ASTM International Headquarters. Request RR:E05-1001.

The points on the curve that determine its character are:

1000°F (638°C)	at 5 min
1300°F (704°C)	at 10 min
1550°F (843°C)	at 30 min
1700°F (926°C)	at 1 h
1850°F (1010°C)	at 2 h
2000°F (1093°C)	at 4 h
2300°F (1260°C)	at 8 h or over

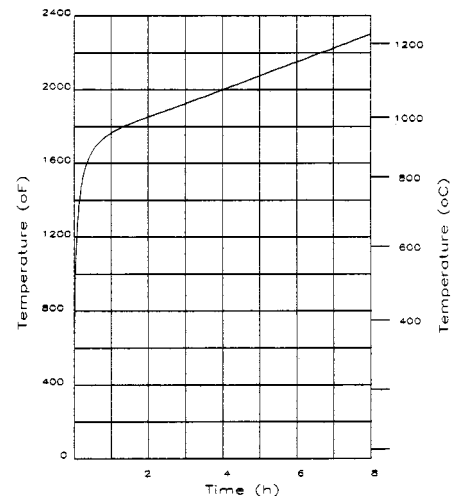

FIG. 4 Standard Time-Temperature Curve

**TABLE 1 Standard Time-Temperature Curve for Control of Fire Tests**

Time (h/min)	Temperature	Area Above 68°F base		Temperature	Area Above 20°C base	
	(°F)	(°F·min)	(°F·h)	(°C)	(°C·min)	(°C·h)
0:00	68	0	0	20	0	0
0:05	1 000	2 330	39	538	1 290	22
0:10	1 300	7 740	129	704	4 300	72
0:15	1 399	14 150	236	760	7 860	131
0:20	1 462	20 970	350	795	11 650	14
0:25	1 510	28 050	468	821	15 590	260
0:30	1 550	35 360	589	843	19 650	328
0:35	1 584	42 860	714	862	23 810	397
0:40	1 613	50 510	842	878	28 060	468
0:45	1 638	58 300	971	892	32 390	540
0:50	1 661	66 200	1 103	905	36 780	613
0:55	1 681	74 220	1 237	916	41 230	687
1:00	1 700	82 330	1 372	927	45 740	762
1:05	1 718	90 540	1 509	937	50 300	838
1:10	1 735	98 830	1 647	946	54 910	915
1:15	1 650	107 200	1 787	955	59 560	993
1:20	1 765	115 650	1 928	963	64 250	1 071
1:25	1 779	124 180	2 070	971	68 990	1 150
1:30	1 792	132 760	2 213	978	73 760	1 229
1:35	1 804	141 420	2 357	985	78 560	1 309
1:40	1 815	150 120	2 502	991	83 400	1 390
1:45	1 826	158 890	2 648	996	88 280	1 471
1:50	1 835	167 700	2 795	1 001	93 170	1 553
1:55	1 843	176 550	2 942	1 006	98 080	1 635
2:00	1 850	185 440	3 091	1 010	103 020	1 717
2:10	1 862	203 330	3 389	1 017	112 960	1 882
2:20	1 875	221 330	3 689	1 024	122 960	2 049
2:30	1 888	239 470	3 991	1 031	133 040	2 217
2:40	1 900	257 720	4 295	1 038	143 180	2 386
2:50	1 912	276 110	4 602	1 045	153 390	2 556
3:00	1 925	294 610	4 910	1 052	163 670	2 728
3:10	1 938	313 250	5 221	1 059	174 030	2 900
3:20	1 950	332 000	5 533	1 066	184 450	3 074
3:30	1 962	350 890	5 848	1 072	194 940	3 249
3:40	1 975	369 890	6 165	1 079	205 500	3 425
3:50	1 988	389 030	6 484	1 086	216 130	3 602
4:00	2 000	408 280	6 805	1 093	226 820	3 780
4:10	2 012	427 670	7 128	1 100	237 590	3 960
4:20	2 025	447 180	7 453	1 107	248 430	4 140
4:30	2 038	466 810	7 780	1 114	259 340	4 322
4:40	2 050	486 560	8 110	1 121	270 310	4 505
4:50	2 062	506 450	8 441	1 128	281 360	4 689
5:00	2 075	526 450	8 774	1 135	292 470	4 874
5:10	2 088	546 580	9 110	1 142	303 660	5 061
5:20	2 100	566 840	9 447	1 149	314 910	5 248
5:30	2 112	587 220	9 787	1 156	326 240	5 437
5:40	2 125	607 730	10 129	1 163	337 630	5 627
5:50	2 138	628 360	10 473	1 170	349 090	5 818
6:00	2 150	649 120	10 819	1 177	360 620	6 010
6:10	2 162	670 000	11 167	1 184	372 230	6 204
6:20	2 175	691 010	11 517	1 191	383 900	6 398
6:30	2 188	712 140	11 869	1 198	395 640	6 594
6:40	2 200	733 400	12 223	1 204	407 450	6 791
6:50	2 212	754 780	12 580	1 211	419 330	6 989
7:00	2 225	776 290	12 938	1 218	431 270	7 188
7:10	2 238	797 920	13 299	1 225	443 290	7 388
7:20	2 250	819 680	13 661	1 232	455 380	7 590
7:30	2 262	841 560	14 026	1 239	467 540	7 792
7:40	2 275	863 570	14 393	1 246	479 760	7 996
7:50	2 288	885 700	14 762	1 253	492 060	8 201
8:00	2 300	907 960	15 133	1 260	504 420	8 407

7.1.2 The temperature inside the furnace recorded at the start of the test shall be considered ambient.

## 8. Furnace Temperatures

8.1 The temperatures of the test exposure shall be deemed to be the average temperature obtained from the readings of not

less than nine thermocouples symmetrically disposed and distributed to show the temperature near all parts of the test assembly (see X1.6).

8.2 Originally locate the junction of the thermocouples  $6 \pm 0.25$  in. ( $152 \pm 6$  mm) from the exposed face of the test assembly or from the wall or partition in which the assembly is installed.

8.2.1 Verify the distance established in 8.2 at intervals not exceeding 10 min during the first 30 min of the test and thereafter at intervals not exceeding 30 min.

8.2.2 If the distance is not as specified in 8.2, reset the distance to comply with 8.2.

8.3 The furnace temperatures shall be measured and recorded at intervals not exceeding 1 min.

8.4 The accuracy of the furnace control shall be such that the area under the time-temperature curve, obtained by averaging the results from the thermocouple readings, is within 10 % of the corresponding area under the standard time-temperature curve for fire tests of 1 h or less duration, within 7.5 % for those over 1 h and not more than 2 h, and within 5 % for tests exceeding 2 h in duration.

## 9. Furnace Pressure

9.1 The pressure in the furnace shall be measured using pressure-sensing probes which comply with 6.2 (see Appendix X1.10).

9.2 The pressure in the furnace shall be measured using at least two probes located within the furnace and separated by a vertical distance of at least 6 ft. (1.8 m).

9.3 Locate the probes as near to the centerline of the furnace opening as practical.

9.4 Use a differential pressure measurement instrument which complies with 5.3 to measure the pressure. Locate the differential pressure measurement instrument to minimize the “stack” effects caused by vertical runs of pressure tubing between the furnace probe and instrument locations.

## 10. Test Assemblies

### 10.1 Construction and Size:

10.1.1 Make the window assembly full size (see X1.8). Make the design, construction, material, workmanship, and hardware of the test window assembly representative of that for which approval is desired. Keep a record of materials and construction details adequate for identification.

10.1.2 Do not allow the area of the test assembly to be less than 100 ft<sup>2</sup> (9m<sup>2</sup>), or either dimension less than 9 ft (2.7 m). If the conditions of use limit the construction to smaller dimensions, a proportionate reduction is permitted to be made in the dimensions of the test assembly for tests qualifying them only for such restricted use.

### 10.2 Installation

10.3 Place the window assembly in a wall or partition. Make the wall or partition in which the window assembly that is to be tested shall be:

10.3.1 Adequate to retain the window assembly throughout the fire and hose stream test, and

10.3.2 Constructed of masonry or other materials representative of wall or partition construction.

### 10.4 Mounting:



10.4.1 Mount the window assembly in the wall or partition in the manner in which it is to be used.

10.4.2 Mount it so that the latches and fasteners, other than hinges, shall be on the unexposed side, but do not allow such mounting to prevent the free and easy operation of all operable components such as ventilators and sash.

## 11. Test Procedure

11.1 Position and secure the test assembly against the furnace opening.

11.2 Simultaneously start the fire endurance test, measuring devices and data acquisition equipment. Follow the time-temperature curve described in Section 7.

11.3 Measure the pressure at each probe location using a differential pressure measurement instrument.

11.4 Calculate the location of the neutral plane (zero differential pressure) using the vertical separation distance and pressure differences between the probes.

11.5 Within the first 5 min of the fire test, establish the neutral pressure plane in the furnace so that at least the upper two-thirds of the window assembly is under positive pressure.

11.6 Read and record the differential pressures at intervals not exceeding 1 min throughout the fire test.

11.7 After the pressure profile in 11.5 is established (using the measurements at the locations specified 9.2), control the furnace pressure for the remainder of the fire test so that the established pressure (at the locations specified 9.2) will not be decreased for the last 25 % of the fire exposure period and an aggregate time period of:

11.7.1 Ten percent of the fire exposure for fire tests of 1 h or less,

11.7.2 Seven and one-half percent of the fire exposure for fire tests longer than 1 h but not longer than 2 h, and

11.7.3 Five percent of the fire exposure for fire tests exceeding 2 h in duration.

11.8 Continue the fire endurance test until the exposure period of the desired classification or rating is reached unless the minimum requirements set forth in Section 13 are exceeded in a shorter period.

11.9 Immediately following the fire endurance test, subject the test assembly to a hose stream delivered through a system as described in 6.4 (see X1.11).

11.10 Locate the tip of the nozzle  $20 \pm 0.3$  ft ( $6 \pm 0.1$  m) from, and on a line normal to, the center of the test window. If impossible to be so located, the nozzle shall be permitted to be on a line deviating not more than  $30^\circ$  from the line normal to the center of the test window. When so located the distance from the center shall be less than  $20 \pm 0.3$  ft ( $6 \pm 1$  m) by an amount equal to  $1 \pm 0.015$  ft ( $0.3 \pm 0.005$  m) for each  $10^\circ$  of deviation from the normal.

11.11 Establish the water pressure at the base of the nozzle as prescribed in Table 2 for the desired rating.

11.12 One method to calculate the exposed area is using the outside dimensions of the test specimen, including a frame, hangers, tracks, or other parts of the assembly if provided, but normally not including the wall or partition into which the specimen is mounted. Where multiple test specimens are mounted in the same wall or partition, the rectangular or square wall or partition area encompassing all of the specimens shall

**TABLE 2 Water Pressure at Base of Nozzle and Duration of Application**

Desired Rating (Fire Endurance Classification)	Water Pressure at Base of Nozzle, psi (kPa)	Duration of Application, s/ft <sup>2</sup> (s/m <sup>2</sup> ) exposed area
3 h	45 (310)	3.0 (32)
1 ½ h and over, if less than 3 h	30 (207)	1.5 (16)
1 h and over, if less than 1 ½ h	30 (207)	0.9 (10)
Less than 1 h	30 (207)	0.6 (6)

be considered as the exposed area since the hose stream must traverse this area during its application.

11.13 Direct the hose stream first at the bottom and then at all parts of the exposed surface, making changes in direction slowly. Keep the hose stream moving across the test assembly. Do not concentrate, or stop, the hose stream on any point on the test assembly. Changes in direction of the hose stream shall be made within 1 ft (310 mm) outside of the perimeter edge of the window assembly. The following pattern is to be followed:

11.13.1 Direct the hose stream around the periphery of the window assembly, starting upward from either bottom corner.

11.13.2 After the hose stream has covered the periphery, apply the hose stream in vertical paths approximately 1 ft (310 mm) apart until the entire width has been covered.

11.13.3 After the hose stream has covered the width, apply the hose stream in horizontal paths approximately 1 ft (310 mm) apart until the entire height has been covered.

11.14 Maintain the hose stream on the test assembly for the duration of application in s/ft<sup>2</sup> (s/m<sup>2</sup>) of exposed area as prescribed in Table 2. When the required duration has not been reached before 11.13 is complete, then repeat 11.13 in reverse.

## 12. Conditions Of Compliance (See X1.12)

### 12.1 Fire Endurance Test:

12.1.1 A window assembly shall be considered as meeting the requirements for acceptable performance when it remains in the wall or partition during the fire endurance test within the following limitations:

12.1.1.1 There shall be no separation of the glazing material edges from the glazing frame so as to create any through-openings.

12.1.1.2 Movement at the perimeter of operable components, from the initial closed position, shall not exceed the thickness of the frame member at any point.

12.1.1.3 No flaming shall occur on the unexposed face of the test assembly.

12.1.1.4 The window shall not move away from the wall or partition to create a through-opening.

12.1.1.5 There shall be no through-openings in the window assembly.

12.1.2 A glass block assembly shall be considered as meeting the requirements for acceptable performance when it remains in the test frame during the fire endurance test within the following limitations:

12.1.2.1 No flaming shall occur on the unexposed face of the test assembly.

12.1.2.2 There shall be no through-openings in any of the individual glass blocks or the joints between the individual glass blocks or between the glass blocks and the test frame.

## 12.2 Hose Stream Test:

12.2.1 A window assembly shall be considered as meeting the requirements for acceptable performance when it remains in the wall or partition during the hose stream test within the following limitations:

12.2.1.1 Movement at the perimeter of operable components, from the initial closed position, shall not exceed the thickness of the frame member at any point.

12.2.1.2 Separation of the glazing material edges from the glazing frame so as to create any through-openings shall not exceed 30 % of the perimeter of any individual glass light.

12.2.1.3 Through-openings created by glazing material breakage in the central area of any individual glass light shall not exceed 5 % of the area of each individual glass light.

12.2.2 A glass block assembly shall be considered as meeting the requirements for acceptable performance when it remains in the test frame during the hose stream test within the following limitations:

12.2.2.1 At least 70 % of the glass blocks shall not develop through-openings.

## 13. Report

13.1 Report results in accordance with the performance in the tests as prescribed in this fire-test-response standards. The report shall include, but shall not be limited to, the following:

13.1.1 Description of the wall or partition in which the window assembly is mounted for testing.

13.1.2 Temperature measurements of the furnace on a comparative graph with the standard time-temperature curve (Section 6).

13.1.3 All observations of the reaction to fire of the test assembly that will possibly have an effect on its performance, during both the fire and hose stream tests.

13.1.4 Condition of the window assembly and its fastenings after both the fire and hose stream tests.

13.1.5 Amount and nature of the movement of any operable components from the initial closed position.

13.1.6 For fire window assemblies, report the condition of the individual glass lights including movement of the edges and the percentage and location of fragments dislodged during the tests.

13.1.7 For glass blocks, report any loosening of the blocks in the frames and any through-openings.

13.1.8 Materials and construction of the fire window assembly, details of installation including latches, hinges, and fasteners used for mounting, and the size of the glazed area shall be recorded or referenced to assure positive identification or duplication in all respects.

13.1.9 Pressure measurements made between the furnace and the unexposed face of the test assembly and the calculations used to determine the location of the neutral plane relative to the top of the window assembly during the test. A statement whether or not the upper two-thirds of the window assembly is subjected to positive pressure.

13.1.10 The performance for the desired exposure period obtained in accordance with the conditions of compliance from the following: 20 min, 30 min, 45 min, 1 h, 1-½ h, 2 h, 3 h or over in hourly increments.

NOTE 4—Typically windows are tested to a maximum of 45 min, however, a higher rating may be required for some reason. The test method should be able to accommodate this possibly.

13.1.11 When the fire endurance rating is 30 min or longer, a correction shall be applied for variation in the furnace exposure time from that prescribed in those cases where it affects the fire endurance rating. This shall be done by multiplying the indicated duration by  $\frac{2}{3}$  of the difference in area between the curve of the average furnace temperature and the standard time-temperature curve for the first  $\frac{3}{4}$  of the test duration and then dividing the product by the difference in area between the standard time-temperature curve and a baseline of 68°F (200°C) for the same portion of the test, increasing the latter area by 54°F/h (30°C/h) [3240°F/min (1800°C/min)], to compensate for the thermal lag of the furnace thermocouples during the first part of the test. For fire exposure in the test higher than the standard time-temperature curve, indicated fire endurance rating shall be increased by the amount of the correction and shall be decreased similarly for fire exposure below the standard time-temperature curve.

The correction shall be expressed by the following formula:

$$C = \frac{2I(A-A_s)}{3(AS + L)} \quad (1)$$

where:

$C$  = correction in the same units as  $I$ ,

$I$  = indicated fire endurance rating,

$A$  = area under the curve of the indicated average furnace temperature for the first  $\frac{3}{4}$  of the indicated rating period,

$A_s$  = area under the standard time-temperature curve for the same part of the indicated fire endurance rating, and

$L$  = lag correction in the same units as  $A$  and  $A_s$  54°F/h (30°C/h) [3240°F/min (1800°C/min)].

13.1.12 The results of the hose stream test. A concise statement shall indicate whether the window assembly passed or failed.

13.1.13 The laboratory's name, project number, date tested, sponsor, and a description of the laboratory test facility and equipment, including the furnace, test frame, etc.

## 14. Precision and Bias

14.1 Precision and bias of this fire-test-response test method for measuring the response of window assemblies to heat and flame under controlled laboratory conditions are essentially as specified in Test Method E 119. No information is presented about either the precision and bias of this fire-test-response standard for measuring the response of window assemblies to a standard hose stream under controlled laboratory conditions since the test is non-quantitative.

## 15. Keywords

15.1 classified; fire; fire endurance; fire-rated assembly; fire-test-response standard; glass blocks; glazing; hose stream; windows

## APPENDIX

### (Nonmandatory Information)

#### X1. COMMENTARY

##### X1.1 Introduction

X1.1.1 This commentary has been prepared to provide the user of this fire-test-response test method with background information on the development of the standard and its application in fire protection of buildings. It also provides guidance in the planning and performance of fire tests and in the reporting of results. No attempt has been made to incorporate all the available information on fire testing in this commentary. The serious student of fire testing is strongly urged to peruse the reference documents for a better appreciation of the intricate problems associated with testing and with interpretation of test results.

##### X1.2 Application

X1.2.1 Openings in the exterior walls of buildings have contributed to the spread of fire from one building to another through radiant and convective transfer of heat, and from one compartment to another within a building. Fire Protection Standards **(1, 2)**<sup>7</sup> and Building Codes **(3)** recognize the hazard of exterior wall or partition openings when adequate spatial separation does not exist to minimize the danger. Where the spatial separation is not entirely adequate and the expected fire exposure is moderate or light, these regulations do allow window openings to facilitate functional use of the building. However, the window openings must have some protection. This protection is provided by properly designed windows and glass block assemblies. Where sustained severe exposures are possible, it is recommended that the openings be protected with fire window assemblies.

X1.2.2 These same fire window assemblies are sometimes specified to protect paths of travel from interior fires such as windows abutting exterior stairs and fire escapes and in corridors where wall or partition openings are used to provide natural lighting of the corridor from adjacent rooms.

##### X1.3 Scope and Significance

X1.3.1 This fire-test-response test method provide a method for evaluating the effectiveness of light-transmitting opening protectives to remain in place for moderate durations of exposure.

X1.3.2 The window assembly is exposed to predetermined fire conditions for a specified period of time and then subjected to a standard hose stream impact test.

X1.3.3 These methods do not measure or evaluate the heat transmission or radiation through the assembly. Consult the National Fire Protection Association Standard No. 80A **(1)** "Protection of Buildings from Exterior Fire Exposures" for information on exterior fire exposure problems **(1,2,4)**.

X1.3.4 Openings in walls or partitions, even when protected, provide lower fire protection than the wall or partition. Under normal circumstances, provide clear spaces on both sides of the protective. The designed protection is not normally expected if combustibles are located directly in front of or behind the opening protectives **(4,5)**.

##### X1.4 Furnace

X1.4.1 This test methods provide details on the operating characteristics and of furnace refractory materials and are sufficiently rugged to maintain the overall integrity of the furnace during the fire-exposure period.

X1.4.2 The thermocouples in the furnace are located 6 in. (152 mm) from the face of the window or the wall or partition in which the window assembly is installed. Otherwise no furnace depth is specified. A depth of 8 to 18 in. (203 to 457 mm) has been considered desirable by most laboratories. The reader is urged to consult reference documents for a more comprehensive review of furnace design and performance **(6,7)**.

##### X1.5 Temperature-Time Curve

X1.5.1 A specific temperature-time relationship for the test fire is defined in this fire-test-response standard. The actual recorded temperature-time condition obtained in the furnace during the test as measured by the area under the *T-t* curve is required to be within specified percentages of those of the standard curve. The number and type of temperature-measuring devices are outlined in this fire-test-response standard. Specific standard practices for location and use of these temperature-measuring devices are also outlined in these test methods.

X1.5.2 The standard temperature-time curve used in this fire-test-response standard is considered to represent a relatively severe building fire **(6)**. The curve was adopted in 1918 as a result of several conferences by eleven technical organizations, including testing laboratories, insurance underwriters, fire protection associations, and technical societies **(8, 9, 10)**. Recognize that the *T-t* relationship of these fire-test-response standards represents only one real fire situation **(11-20)**.

##### X1.6 Furnace Control

X1.6.1 This fire-test-response test method contains specific instruction for measuring temperatures in the furnace and for the selection of required thermocouples. Thermocouples of the design specified are sufficiently rugged to retain accuracy throughout anticipated test periods. However, their massive construction results in a significant time delay in response to temperature change and results in temperatures exceeding the indicated temperatures during the early stages of the test period when the temperature rises rapidly. The iron or porcelain tubes

<sup>7</sup> The boldface numbers given in parentheses refer to a list of references at the end of the text.

surrounding the junction and leads of the thermocouple provide a shield against degradation of the junction and increase the thermal inertia. It is customary for laboratories to replace furnace thermocouples after three or four accumulated hours of use.

### X1.7 Unexposed Surface Temperature

X1.7.1 Conditions of compliance for fire-resistive walls or partitions specify that the temperature increase on the unexposed side of the wall or partition not exceed 250°F (139°C) average for the various thermocouples and that there be no passage of flame, and gases hot enough to ignite combustibles. It is obvious that the very nature of a fire window (wire glass or glass block) precludes both criteria for this fire-test-response test method and radiation must be expected.

### X1.8 Test Assemblies

X1.8.1 Fire window assemblies are tested in relatively large sizes compared with most windows, that is, 100 ft<sup>2</sup> (9.3 m<sup>2</sup>) in area have been tested. When assemblies are less than 100 ft<sup>2</sup> in size, this fact should be reported as an exception.

### X1.9 Conduct of Tests

X1.9.1 It is recommended that the test frame or wall or partition in which a window assembly is installed be rugged enough to endure the exposed fire during the time period, without affecting the window assembly. Traditionally this wall or partition has been of masonry construction. Today, fire windows are installed in other than masonry walls and have been tested in these walls or partitions.

### X1.10 Furnace Pressures

X1.10.1 A fire in a building compartment will create both negative and positive pressures on window assemblies depend-

ing upon atmospheric conditions, height above ground, wind conditions and ventilation of the compartment at the beginning and during the fire.

### X1.11 Hose Stream Test

X1.11.1 Immediately following a fire test, the test frame is removed from the furnace and the window assembly is subjected to the impact, erosion, and cooling effects of a stream of water from a 2 ½ in. (63.5 mm) hose discharging through a standard play pipe equipped with a 1 ½ in. (28.5 mm) tip under specified pressures. The application of water produces stresses in the assembly and provides a measure of its structural capability. Weights were once used to provide a measure of the ability of the assembly to withstand impact. The hose stream is considered to be an improvement in uniformity and accuracy over the weights.

### X1.12 Conditions of Compliance

X1.12.1 During the fire exposure test, the fire window assembly must stay in place and not be loosened from the test frame or develop any openings around the perimeter of the frame or the individual glass lights. During the hose stream test, the window assembly must remain in place but is permitted to have glass dislodged from the central portion of each glass light as long as the amount dislodged does not exceed 5 % of the area of each individual light. Also during the hose stream test, separation of the glass edges from the frame by movement away from the frame so as to create a through opening is limited to 30 % of the perimeter of any individual glass light. At least 70 % of the glass blocks shall not develop through openings.

### X1.13 Additional Information

X1.13.1 Address inquiries concerning this fire-test-response test method to ASTM Subcommittee E05.11.

## REFERENCES

- (1) NFPA 80A, "Recommended Practice for Protection of Buildings from Exterior Fire Exposure," National Fire Protection Assn.
- (2) NFPA 80, "Fire Doors and Windows," National Fire Protection Assn.
- (3) Model Codes: *National Building Code* Building Official & Code Administrators International Inc. *Uniform Building Code*-International Conference of Building Officials Inc. *Standard Building Code*-Southern Building Code Congress International *National Building Code*-American Insurance Assn.
- (4) Harmathy, T.Z., "Performance of Building Elements in Spreading Fire," DBR Paper No. 752, National Research Council of Canada, NRCC 16437, *Fire Research*, Vol 1, 1977/78, pp. 119–132.
- (5) Gross, Daniel, and Robertson, A.F., *Experimental Fires in Enclosures*, Tenth Symposium (International) on Combustion, The Combustion Institute, 1965, pp. 931–942.
- (6) Seigel, L.G., "Effects of Furnace Design on Fire Endurance Test Results," *Fire Test Performance, ASTM STP 464*, ASTM, 1970, pp. 57–67.
- (7) Harmathy, T.Z., "Design of Fire Test Furnaces," *Fire Technology*, Vol 5, No. 2, May 1969, pp. 146–150.
- (8) Babrauskas, Bytenis; Williamson, Robert Brady, "Historical Basis of Fire Resistance Testing, Part I and Part II," *Fire Technology*, Vol 14, No. 3 and No. 4, 1978, pp. 184–194; 304–316.
- (9) *Fire Protection Handbook*, Revised Fourteenth Edition, National Fire Protection Assn., Boston, 1978.
- (10) Harmathy, T.Z., "Designers Option: Fire Resistance or Ventilation," Technical Paper No. 436, Division of Building Research, National Research Council of Canada, Ottawa, NRCC 14746.
- (11) Seigel, L.G., "The Severity of Fires in Steel-Framed Buildings," Symposium No. 2, Her Majesty's Stationery Office, 1968, London, Proceedings of the Symposium held at the Fire Research Station, Boreham Woods, Herts (England) on Jan. 24, 1967.
- (12) Odeen, Kai, "Theoretical Study of Fire Characteristics in Enclosed Spaces," *Bulletin No. 10*, Royal Institute of Technology, Division of Building Construction, Stockholm, 1963.
- (13) Shorter, G.W., "Fire Protection Engineer and Modern Building Design," *NFPA Fire Technology*, Aug., 1968.
- (14) *Wall Street Journal*, Dec. 8, 1970, "Danger - Flammable," by-line Richard Stone.
- (15) Ryan, J.E., "Assessment of Fire Hazards in Buildings," *Ignition, Heat Release, and Noncombustibility of Materials, ASTM STP 502*, ASTM, 1972.
- (16) Harmathy, T.Z., "Design Approach to Fire Safety in Buildings," *Progressive Architecture*-April 1974, pp. 82–87, NRCC 14076.
- (17) Harmathy, T.Z., "A New Look at Compartment Fires, Part I and Part



- II,” *Fire Technology*, Vol 8, No. 3 and No. 4, 1972 pp. 196–217; 326–351.
- (18) Heselden, A.J.M., *Parameters Determining the Severity of Fire*, Symposium No. 2, Her Majesty’s Stationery Office, 1968, London, Proceedings of the Symposium held at the Fire Research Station, Boreham Woods, Herts (England) on Jan. 24, 1967.
- (19) Law, Margaret, “Radiation from Fires in a Compartment,” Fire Research Technical Paper No. 20, Her Majesty’s Stationery Office, London, 1968.
- (20) Konicek, L., and Lie, T.T., *Temperature Tables for Ventilation Controlled Fires*, Building Research Note No. 94, National Research Council of Canada, September 1974.

*ASTM International takes no position respecting the validity of any patent rights asserted in connection with any item mentioned in this standard. Users of this standard are expressly advised that determination of the validity of any such patent rights, and the risk of infringement of such rights, are entirely their own responsibility.*

*This standard is subject to revision at any time by the responsible technical committee and must be reviewed every five years and if not revised, either reapproved or withdrawn. Your comments are invited either for revision of this standard or for additional standards and should be addressed to ASTM International Headquarters. Your comments will receive careful consideration at a meeting of the responsible technical committee, which you may attend. If you feel that your comments have not received a fair hearing you should make your views known to the ASTM Committee on Standards, at the address shown below.*

*This standard is copyrighted by ASTM International, 100 Barr Harbor Drive, PO Box C700, West Conshohocken, PA 19428-2959, United States. Individual reprints (single or multiple copies) of this standard may be obtained by contacting ASTM at the above address or at 610-832-9585 (phone), 610-832-9555 (fax), or [service@astm.org](mailto:service@astm.org) (e-mail); or through the ASTM website ([www.astm.org](http://www.astm.org)).*