



Standard Test Method for Determining the Carbon Dioxide Loss of Beverage Containers¹

This standard is issued under the fixed designation F 1115; the number immediately following the designation indicates the year of original adoption or, in the case of revision, the year of last revision. A number in parentheses indicates the year of last reapproval. A superscript epsilon (ϵ) indicates an editorial change since the last revision or reapproval.

1. Scope

1.1 The objective of this test method is to determine the carbon dioxide (CO₂) loss from plastic beverage containers after a specified period of storage time.

1.2 Factors contributing to this pressure loss are volume expansion and the gas transport characteristics of the package including permeation and leakage.

1.3 *This standard does not purport to address all of the safety concerns, if any, associated with its use. It is the responsibility of the user of this standard to establish appropriate safety and health practices and determine the applicability of regulatory limitations prior to use.*

2. Referenced Documents

2.1 ASTM Standards:

D 1129 Terminology Relating to Water²

D 1193 Specification for Reagent Water²

E 177 Practice for Use of the Terms Precision and Bias in ASTM Test Methods³

E 380 Practice for Use of the International System of Units (SI) (the Modernized Metric System)³

E 691 Practice for Conducting an Interlaboratory Study to Determine the Precision of a Test Method³

3. Terminology

3.1 Units, symbols, and abbreviations used in this test method are those recommended by Practice E 380.

3.2 Definitions of Terms Specific to This Standard:

3.2.1 *carbonation volume*—the volume of CO₂ (at 0°C, 1 atm pressure) that is dissolved in the carbonated water, divided by the volume of the liquid (based on water volume at 3.98°C equals 1.000 g/cm³). The conversion of pressure to carbonation volumes should be made using a carbonation volumes table. A table for carbonated water would not necessarily apply to liquids containing additional substances, such as carbonated beverages containing sugar.

3.2.2 *initial pressure*—the equilibrium pressure in the test bottles as measured at 24 h after filling with carbonated water. (The filled bottles are allowed to stand for 24 h to obtain temperature equilibrium with the test environment and to allow time for pressure adjustment and equilibration of the CO₂ in the headspace and liquid.)

3.2.3 *sample*—a set of bottles produced on the same equipment in a single run and using the same material and process conditions. Bottles should represent normal thickness distribution.

3.2.4 *shelf life*—the number of weeks a sample set of bottles retain a specified carbonation level, or a percent of the initial level.

3.2.5 *pressure monitoring device*—a pressure gage or transducer assembly with support electronics for indicating internal pressure level of the bottle. This device is used with brass closure fitting-equipped bottles.

3.2.5.1 *temperature monitoring device*—a thermocouple with support electronics (same equipment as described in 7.2.2). A precision glass thermometer may be used provided a bottle filled with noncarbonated water is used as a control in each sample set (Procedure A).

3.2.6 *Terriss CO₂ Analyzer*—an electronic unit that will pierce the roll-on closure and automatically read pressure, temperature, and volume of gas (Procedure B).

3.2.7 *Zahm-Nagle Pressure Tester*—a unit that manually pierces the closure and measures container pressure; an attached thermometer is then used to measure temperature (Procedure B).

3.2.8 *support ring*—a protrusion below the bottle finish which is used to support or stabilize the bottle during filling and capping.

3.2.9 *finish*—the threaded part of the bottle which receives the cap.

3.3 For other terms used in this test method, refer to Terminology D 1129.

4. Summary of Test Method

4.1 Test bottles are filled with carbonated water or beverage and, after closure application, are exposed to test environments for specified time periods. By periodically measuring the initial and final carbonation levels in the container, the loss and rate can be calculated.

¹ This test method is under the jurisdiction of ASTM Committee F2 on Flexible Barrier Materials and is the direct responsibility of Subcommittee F02.30 on Test Methods.

Current edition approved Sept. 10, 1995. Published March 1996. Originally published as F 1115 – 87. Last previous edition F 1115 – 87.

² *Annual Book of ASTM Standards*, Vol 11.01.

³ *Annual Book of ASTM Standards*, Vol 14.02.

5. Significance and Use

5.1 Two procedures, A and B, are outlined in this test method. Procedure A is used most often for development of various beverage container designs to determine the functional characteristics of the package in regard to shelf life. Procedure B is recommended for use in beverage filling operations as a quality control tool in maintaining the desired CO₂ fill pressure. A loss of CO₂ will affect product taste.

5.1.1 Procedure A involves the use of sensitive pressure and temperature monitoring equipment where a high degree of accuracy is essential, for example, a micro-pressure transducer and thermocouple for measuring pressure and temperature of the package in a closed system. Alternatively, this procedure may also use bottles closed with roll-on aluminum caps containing rubber septums. The septum is pierced with a hypodermic needle attached to a pressure transducer to obtain pressure readings. This procedure should be confined to laboratories that are practiced in this type of analytical testing.

5.1.2 Procedure B is more widely used when measuring the carbonation level of the package due to the simplicity of the technique. A simple Zahm-Nagle pressure assembly or Terris CO₂ Analyzer is utilized.

6. Interferences

6.1 The following conditions can interfere with the test results:

- 6.1.1 CO₂ leakage at closure due to defective bottle finish or improper sealing of closure apparatus,
- 6.1.2 CO₂ leakage due to improper equipment set-up,
- 6.1.3 Change in ambient temperature, upsetting the equilibrium of the headspace and dissolved CO₂ gas,
- 6.1.4 Measurement of pressure before the bottle and liquid have reached ambient temperature,
- 6.1.5 Inaccurate thermocouple device used for measuring the liquid temperature,
- 6.1.6 Excessive air in the bottle headspace or dissolved in the liquid,
- 6.1.7 Inaccurate or erratic pressure monitoring device,
- 6.1.8 Ambient humidity in the test area,
- 6.1.9 Age of bottles, and
- 6.1.10 Excessive bottle-to-bottle variation in the material distribution, which may result in a wide variation from bottle to bottle within the sample population.

7. Apparatus

- 7.1 *Procedures A and B:*
 - 7.1.1 *Bottle Stand*, optional.
 - 7.1.2 *Height Measuring Device*, capable of measuring to within 0.001 in. (optional).
 - 7.1.3 *Top Loading Balance*, capable of weighing to 2500 g with an accuracy of ±0.01 g (optional).
 - 7.1.4 *Outside Diameter Measuring Device*, π tape or similar device (optional).⁴
 - 7.1.5 *Carbonated Water or Beverage Dispensing Equipment*.

⁴ Tape 57399, available from PI Company, Box 397, Lemon Grove, CA 92045, has been found satisfactory for this purpose.

7.1.6 *Micrometer or Ultrasonic Thickness Gage*, capable of measuring to within 0.001 in. or less (optional).

7.2 Procedure A:

7.2.1 *Machined Metal Cap* (see Fig. 1).

7.2.2 *Temperature-Measuring Device*, capable of accurately measuring temperature in increments of 0.1°C or less in a range from 18 to 32°C (65 to 100°F).⁵

7.2.3 *Pressure-Monitoring Device*.⁶

7.2.4 *Fillpoint-Level Syringe Assembly* (see Fig. 2).

7.3 Procedure B:

7.3.1 *Pressure- and Temperature-Measuring Device*.⁷

8. Reagents and Materials

8.1 Water carbonated to a level sufficient to ensure a minimum carbonation level of 4.5 volumes in the filled bottles. Reagent water conforming to Type IV of Specifications D 1193 or better shall be used.

⁵ Doric Trendicator 410 with copper constantan thermocouple, available from Doric Scientific Div., Emerson Electric Co., 3883 Ruffin Rd., San Diego, CA 92123, has been found satisfactory for this purpose.

⁶ A Pressure Transducer Model AB 0 to 100 psi, available from Data Instruments, Inc., 6 Hartwell Pl., Lexington, MA 02173, with support electronics consisting of a voltmeter calibrated for pressure measurement to within 0.1 psi, has been found satisfactory for this purpose. A calibrated pressure gage has also been found to be satisfactory, for example, an Ashcraft Model 25-1009A02L.

⁷ A Terriss Unit, available from Terriss-Consolidated Industries, Box 110B, Asbury Park, NJ 07712, and a Zahm-Nagle apparatus, available from Zahm and Nagel Co., Inc., 74 Hewett Ave., Buffalo, NY 14214, have been found satisfactory for this purpose.

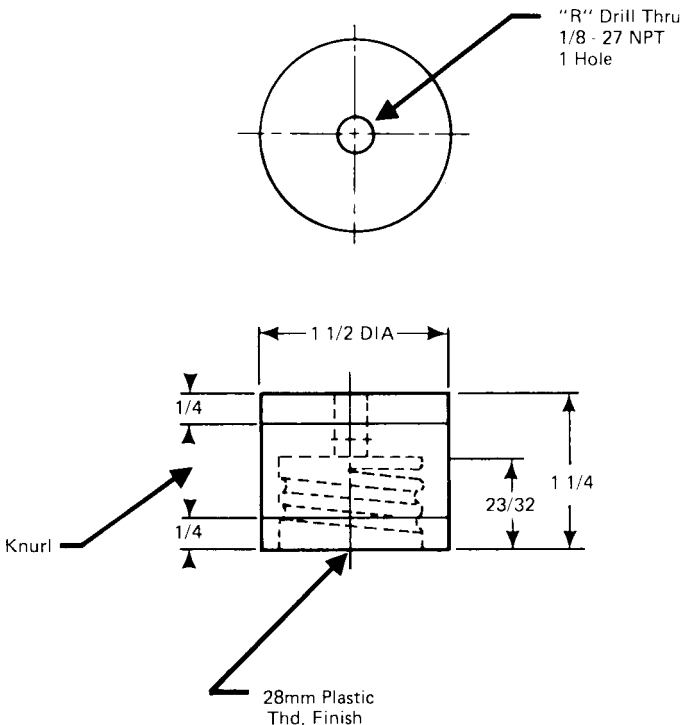

NOTE 1—Break sharp edges. All dimensions are inches unless otherwise stated. If conversion of dimension is desired, use standard equivalence table.

Material: Brass.

FIG. 1 Machined Metal Cap for PET Beverage Bottle Testing

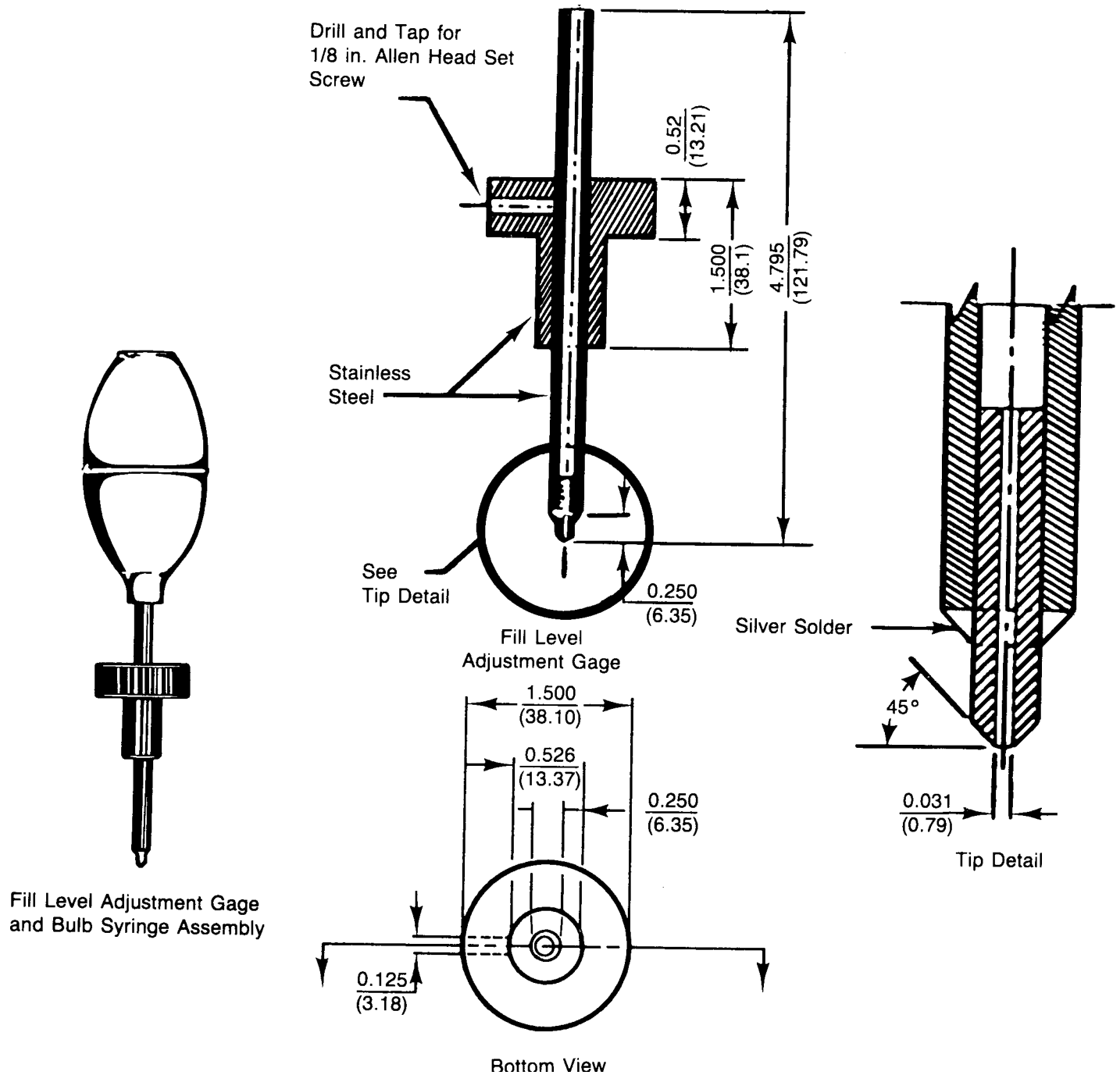

Fill Level Adjustment Gauge and Bulb Syringe Assembly

NOTE 1—Dimensions are in inches and millimetres. Other styles of suction bulbs may be used, including an in-line bulb for use with flexible tubing attached to the gage. The assembly must be adjusted for the specified fill point (from the top down) for the specific bottle size and style being evaluated. The gage may be adjusted using a preset syringe adjusting device or other measuring devices such as the vertical height gage (see 7.1.2). The gage should be set 0.050 in. (1.27 mm) less than the specified value to compensate for the extra liquid withdrawn due to the effect of surface tension.

FIG. 2 Fillpoint Level Adjustment Syringe

8.2 Carbon Dioxide, compressed (CO₂).

8.3 Leak-Detecting Solution.⁸

9. Conditioning

9.1 Test bottles must be conditioned for at least 72 h and

tested at 23°C (73.4°F) ± 2°C, and 50 ± 5 % relative humidity, unless other conditions are agreed upon by the parties involved.

9.2 Bottles may be tested with or without base cup attached.

10. Procedure A

10.1 Apparatus Preparation:

⁸ Snoop Leak Detector, available from Nupro Company, 15635 Saramac Rd., Cleveland, OH 44110, has been found satisfactory for this purpose.

10.1.1 Assemble and calibrate pressure- and temperature-monitoring equipment.

10.1.2 Pressure test assembly at 60 psi using leak detecting solution.

10.1.3 Check calibration of monitoring equipment.

10.2 Record weight and dimensions of empty and filled bottles (optional).

10.2.1 Weigh each empty bottle to at least 0.01 g.

10.2.2 Measure the outside diameter of each empty bottle using a π tape. Measure at the center of the label panel, or other previously agreed upon location(s).

10.2.3 Measure the height of each empty bottle to the bottom of the support ring using a vertical height gage or similar equipment.

10.3 *Filling Bottles:*

10.3.1 Using a carbonating unit or similar equipment, fill containers to the nominal fill level with carbonated water cooled to 5°C (41°F) or below, preferably 1°C (34°F). Samples must be carbonated to no less than 4.5 volumes CO₂. Use Tables X1.1-X1.4 or another table agreed upon by the parties involved to determine CO₂ content by measuring pressure and temperature with the equipment described in Section 7.

10.3.2 Using a fillpoint-level syringe, draw liquid level down to the specified fillpoint.

10.3.3 Immediately after the fillpoint-level adjustment, apply the pressure monitoring apparatus tightly to the bottle. DO NOT AGITATE THE BOTTLE. A brass closure fitted with a micropressure transducer or pressure gage (see Fig. 3) and a thermocouple capable of reading within increments of 0.1°C and 1.0 psi, respectively, or a roll-on aluminum closure fitted with a rubber septum have been found satisfactory for this purpose.

10.3.4 Fill a minimum set of five bottles for each sample.

10.3.5 If the testing device used does not have a temperature sensing probe inside the bottle, fill another bottle with cold noncarbonated water to use as a temperature control for this set of bottles. This bottle should be kept with this set during storage, agitation, and testing. Its temperature shall be used for the temperature of each bottle in the set when determining carbonation level.

10.4 *Pressure Adjustment and Equilibration of Filled Bottles:*

10.4.1 Allow filled bottles to come to ambient storage temperature, and let stand for 24 h in the test environment.

10.4.2 After bottles have equilibrated for 22 h at ambient temperature, agitate the bottles for at least one min using hand shaking or mechanical agitation to ensure proper equilibration of headspace and dissolved CO₂. Sniff pressure or add CO₂ gas as required to adjust the carbonation level to 4.0 volumes \pm 0.05 volumes according to a carbonation volumes table. The starting CO₂ level is critical.

10.4.3 After a total of 24-h equilibration, again agitate the test bottles and determine their carbonation level. If any bottle has a carbonation level of 3.95 volumes or less, discontinue testing of that bottle.

10.5 *Measurements:*

10.5.1 Before filling bottles for the carbonation level test, measure wall thickness profile using suitable equipment to

determine the quality of the material distribution (optional).

10.5.2 Twenty-four hours after filling, agitate each test bottle to equilibrium pressure for at least 1 min to obtain the initial values as outlined below:

10.5.2.1 Equilibrium pressure of each bottle,

10.5.2.2 Temperature of each bottle or the control bottles,

10.5.2.3 Carbonation level (from a carbonation volumes table),

10.5.2.4 Bottle height to the bottom of the support ring (optional),

10.5.2.5 Bottle outside diameter (optional).

10.5.3 Repeat measurements, and agitate bottle for at least 1 min prior to measuring pressure and temperature at 3 days, 1 week, 3 weeks, 6 weeks, 8 weeks, 12 weeks, and 16 weeks. If attached pressure transducers or gages are used, pressure and temperature may be measured more frequently (for example, weekly) either to allow early prediction of shelf life or to obtain a more precise measure of the end point.

10.5.4 If the attached septum method is used, a set of six glass control bottles of the same capacity must be tested along with the plastic bottles. Average loss of these bottles must be subtracted from the loss of the plastic bottles to compensate for CO₂ lost from the septum.

11. Procedure B

11.1 *Apparatus Preparation:*

11.1.1 Ensure proper calibration of the Terris Unit or Zahm-Nagle Apparatus using appropriate manufacturer's guidelines.

11.1.2 Pressure test assembly to ensure no pressure leakage will occur.

11.2 *Test Initiation:*

11.2.1 This test method usually involves filled product containers selected from a commercial beverage location. Select a random sample of at least 50 bottles.

11.2.2 If commercially filled and capped bottles are not available, fill the bottles with either carbonated water or product and apply aluminum roll-on closures using a capper.

11.2.3 Using the Terris Unit, Zahm-Nagle Apparatus, or similar device, pierce the closure and measure the pressure and temperature of at least six bottles.

11.2.4 Agitate each bottle for at least 1 min until the equilibrated pressure and temperature is achieved. This is indicated when the maximum pressure is reached.

11.3 *Measurements:*

11.3.1 Follow the procedure given in 10.5.2 and 10.5.3.

11.3.2 A sample size of at least 50 bottles is needed for a long-term test. Since each bottle is destroyed at each test interval, a minimum of five bottles are needed at each interval outlined in 10.5.3.

12. Calculation

12.1 Calculate the percent of CO₂ retention for each bottle after each measurement (based on an initial carbonation level of 100 %). Calculate the mean average of the CO₂ volumes to determine the percent CO₂ retention of that sample.

Rubber Septum, or a Pressure Gage,
0 to 100 psi, 1 % accuracy
such as Ashcroft 25-1009A02L or
other pressure/temperature sensing device

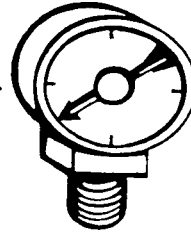

Bell Reducer
Brass 1/4 in. by 1/8 in. NPT



1/8 in. NPT Brass Nipple



Tank Valve
NAPA 90-290
or equivalent



1/8 in. NPT Brass Tee



1/8 in. NPT Brass Nipple



Machined Brass
Cap (Fig. 1)



1.125 in. OD by 0.625 in. ID by 0.125 in. Thick
Rubber Gasket, Garlock White Neoprene
Style 2612-W or equivalent or other
suitable rubber gasket material



SEALANTS

Gage to Brass Bell Reducer:
Teflon Tape-Type Pipe Sealant
Other Brass to Brass Joints:
Epoxy Resin Cement (for ex-
ample, Smooth-On's Metalset A4)

FIG. 3 Pressure Monitoring Assembly

12.2 Plot this data as volumes of CO₂ or percent carbonation retention versus time from the initial reading on rectangular coordinate graph paper and draw a smooth curve through the data points.

12.3 Obtain shelf-life time from the graph by noting the time (in weeks) at which the carbonation level drops below the specified minimum carbonation level.

12.3.1 As a guideline, tests on 2-L bottles should be continued for at least 16 weeks; a 15 % carbonation loss can be used as a guideline to determine the accepted performance (see Fig. 4).

12.4 Alternatively, standard statistical methods may be used to analyze this data and obtain the shelf life.

12.5 Calculate the percent change for each bottle dimension

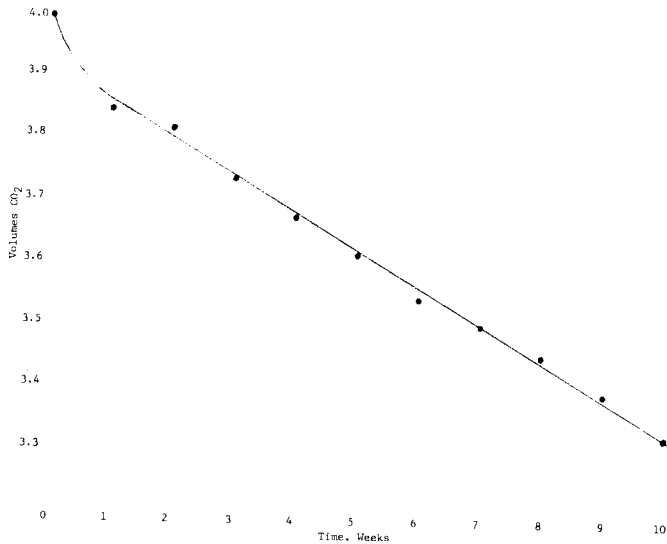

FIG. 4 Example of Carbonation Retention as a Function of Time for 1/2-L PET Bottles

measured, based on the initial values (optional).

13. Report

13.1 The report shall include the following:

- 13.1.1 Number of bottles in the sample.
- 13.1.2 Nominal bottle capacity, size, and style.
- 13.1.3 Initial weight, empty and filled, of each bottle, and thickness profile (optional).
- 13.2 Measurement values for each bottle at each time interval.

- 13.2.1 Overall height to bottom of support ring (optional).
- 13.2.2 Height to liquid level (optional).
- 13.2.3 Outside diameter (optional).
- 13.2.4 Pressure of each bottle.
- 13.2.5 Temperature of each test bottle or temperature of each control bottle.

13.3 Calculated values at each time interval.

13.3.1 Mean average sample carbonation level, obtained from a carbonation volumes table.

13.3.2 Mean average sample percent carbonation loss from the initial value.

13.3.3 Mean average percent carbonation retention of each sample.

13.3.4 Mean average percent change of each dimension measured on each sample as defined in 3.4 (optional).

13.4 Graph of average percent carbonation retention versus time for each sample.

13.4.1 Shelf life obtained from this graph.

13.4.2 Slope of the line.

13.5 Type of carbonation volumes table used, if different from Tables X1.1-X1.4.

13.6 Pressure and temperature measurement device used.

13.7 Type of closure used.

13.8 Conditioning and testing environment if other than specified in 9.1.

14. Precision and Bias

14.1 *Testing*—The data given in Tables X1.1-X1.4 were obtained using Procedure A of this test method. Only one laboratory participated in the data collection. From a single lot of polyethylene terephthalate (PET) more than 100 preforms were molded, stretch blown into 2-L bottles, and then evaluated for carbon dioxide pressure loss. Twelve bottles were randomly selected from the group for the evaluation. Measurements were taken initially and weekly during 16-week test period until a 15 % carbonation loss was observed. Another lot of PET was also molded at a later date into more than 100 1/2-L preforms and stretch blown into bottles in a similar fashion as the before mentioned 2-L bottles. Eighteen bottles were randomly selected from this group and evaluated for their carbon dioxide pressure loss by the method. The measurements for this set were taken initially and weekly for 10 weeks until a 15 % carbonation loss was observed. All of the testing was carried out at ambient conditions in the laboratory with a temperature range of 20 to 25°C and 50 ± 5 % relative humidity.

14.2 *Variability*— Since only one laboratory participated in the evaluation, the repeatability and reproducibility could not be calculated. However, from the data obtained, the expected standard deviation could be calculated. As would be expected, the 1/2-L bottles gave more variation in the measurement and indicated a standard deviation of 1.455. The 2-L bottles has a standard deviation of 0.817. There was a slight upward trend noted for the standard deviation of the 2-L set with respect to increasing carbonation loss while the standard deviation of the 1/2-L set remained fairly constant.

APPENDIX

(Nonmandatory Information)

X1. CARBONATION VOLUMES TABLES

X1.1 Tables X1.1-X1.4 give carbonation volumes.



TABLE X1.3 Volumes of Carbon Dioxide Gas (at STP) Dissolved per Volume of Water (at 3.98°C)³(continued)

Table with columns for PSIG (61-90) and TEMP (°F) (105-91) and rows of numerical data representing CO2 volumes.



TABLE X1.4 Volumes of Carbon Dioxide Gas (at STP) Dissolved per Volume of Water (at 3.98°C)³(continued)

Table with columns for PSIG (91-119) and TEMP °F (105-91) and rows of numerical data representing CO2 volume per volume of water.

Fahrenheit Temperature Versus Pounds Per Square Inch Gage Pressure (Based on Atmospheric Pressure of 14.696 PSI)

 **F 1115**

The American Society for Testing and Materials takes no position respecting the validity of any patent rights asserted in connection with any item mentioned in this standard. Users of this standard are expressly advised that determination of the validity of any such patent rights, and the risk of infringement of such rights, are entirely their own responsibility.

This standard is subject to revision at any time by the responsible technical committee and must be reviewed every five years and if not revised, either reapproved or withdrawn. Your comments are invited either for revision of this standard or for additional standards and should be addressed to ASTM Headquarters. Your comments will receive careful consideration at a meeting of the responsible technical committee, which you may attend. If you feel that your comments have not received a fair hearing you should make your views known to the ASTM Committee on Standards, at the address shown below.

This standard is copyrighted by ASTM, 100 Barr Harbor Drive, PO Box C700, West Conshohocken, PA 19428-2959, United States. Individual reprints (single or multiple copies) of this standard may be obtained by contacting ASTM at the above address or at 610-832-9585 (phone), 610-832-9555 (fax), or service@astm.org (e-mail); or through the ASTM website (www.astm.org).