



Standard Specification for Polyethylene/Aluminum/Polyethylene (PE-AL-PE) Composite Pressure Pipe¹

This standard is issued under the fixed designation F 1282; the number immediately following the designation indicates the year of original adoption or, in the case of revision, the year of last revision. A number in parentheses indicates the year of last reapproval. A superscript epsilon (ϵ) indicates an editorial change since the last revision or reapproval.

1. Scope

1.1 This specification covers a coextruded polyethylene composite pressure pipe with a welded aluminum tube reinforcement between the inner and outer layers. The inner and outer polyethylene layers are bonded to the aluminum tube by a melt adhesive. Included is a system of nomenclature for the polyethylene-aluminum-polyethylene (PE-AL-PE) pipes, the requirements and test methods for materials, the dimensions and strengths of the component tubes and finished pipe, adhesion tests, and the burst and sustained pressure performance. Also given are the requirements and methods of marking. The pipe covered by this specification is intended for use in potable water distribution systems for residential and commercial applications, water service, underground irrigation systems, and radiant panel heating systems, baseboard, snow- and ice-melt systems, and gases that are compatible with composite pipe and fittings.

1.2 This specification relates only to metal and plastic composite pipes incorporating a welded metallic tube. The welded metallic tube of itself is capable of sustaining internal pressures. Pipes consisting of metallic layers not welded together are outside the scope of this specification.

1.3 Specifications for connectors for use with pipe meeting the requirements of this specification are given in Annex A1.

1.4 This specification excludes crosslinked polyethylene-aluminum-crosslinked polyethylene pipes (see Specification F 1281).

1.5 The values stated in SI units are to be regarded as the standard. The values given in parentheses are for information only.

1.6 The following precautionary caveat pertains only to the test methods portion, Section 9, of this specification: *This standard does not purport to address all of the safety concerns, if any, associated with its use. It is the responsibility of the user of this standard to establish appropriate safety and health practices and determine the applicability of regulatory limitations prior to use.*

¹ This specification is under the jurisdiction of ASTM Committee F17 on Plastic Piping Systems and is the direct responsibility of Subcommittee F17.11 on Composite.

Current edition approved Oct. 1, 2003. Published November 2003. Originally approved in 1990. Last previous edition approved in 2002 as F 1282 – 02 ^{ϵ 3}.

2. Referenced Documents

2.1 ASTM Standards:²

- D 618 Practice for Conditioning Plastics for Testing
- D 1248 Specification for Polyethylene Plastics Extrusion Materials for Wire and Cable
- D 1598 Test Method for Time-to-Failure of Plastic Pipe Under Constant Internal Pressure
- D 1599 Test Method for Resistance to Short-Time Hydraulic Pressure of Plastic Pipe, Tubing, and Fittings
- D 1600 Terminology for Abbreviated Terms Relating to Plastics
- D 1898 Practice for Sampling of Plastics
- D 2104 Specification for Polyethylene (PE) Plastic Pipe, Schedule 40
- D 2122 Test Method for Determining Dimensions of Thermoplastic Pipe and Fittings
- D 2837 Test Method for Obtaining Hydrostatic Design Basis for Thermoplastic Pipe Materials
- D 3035 Specification for Polyethylene (PE) Plastic Pipe (DR-PR) Based on Controlled Outside Diameter
- D 3350 Specification for Polyethylene Plastics Pipe and Fittings Materials
- E 8 Test Methods for Tension Testing of Metallic Materials
- F 412 Terminology Relating to Plastic Piping Systems
- F 1281 Specification for Crosslinked Polyethylene/Aluminum/Crosslinked Polyethylene (PEX-AL-PEX) Pressure Pipe
- F 1974 Specification for Metal Insert Fittings for Polyethylene/Aluminum/Polyethylene and Crosslinked Polyethylene/Aluminum/Crosslinked Polyethylene Composite Pressure Pipe

2.2 NSF Standard:

- Standard No. 14 Plastics Piping System Components and Related Materials³
- Standard No. 61 Drinking Water System Components—Health Effects³

² For referenced ASTM standards, visit the ASTM website, www.astm.org, or contact ASTM Customer Service at service@astm.org. For *Annual Book of ASTM Standards* volume information, refer to the standard's Document Summary page on the ASTM website.

³ Available from the NSF International, N. 789 Dixboro Rd., Ann Arbor, MI 48113-0140.

- 2.3 *Uniform Classification Committee Standard:*
Uniform Freight Classification⁴
- 2.4 *National Motor Freight Association Standard:*
National Motor Freight Classification⁵
- 2.5 *Federal Standard:*
Fed. Std. No. 123 Marking for Shipments (Civil Agencies)⁶
- 2.6 *Military Standard:*
MIL-STD-129 Marking for Shipment and Storage⁶

3. Terminology

3.1 *Definitions*—Definitions are in accordance with Terminology F 412, and abbreviations are in accordance with Terminology D 1600, unless otherwise specified.

3.2 *Definitions of Terms Specific to This Standard:*

3.2.1 *assembly*—the joint between a fitting and a length of pipe.

3.2.2 *pipe*—the complete structure, consisting of the aluminum, melt adhesive, and polyethylene layers intimately bonded together. The pipe for this specification is termed a PE-AL-PE composite pipe.

3.2.3 *pipe hoop stress*—for simplicity the value of the hoop stress quoted assumes a homogeneous wall. Local values of stress will vary with the different layers (see 3.2.3.1).

3.2.3.1 *Discussion*—Thick walled plastic pipes produced from one material have hoop stresses that vary through the wall, and are usually described by the Lamé Theory. The composite nature of the PE-AL-PE pipe, composed of materials with very different Young’s Modulus values, will, on pressurization, not have a uniform stress distribution through the thickness of the wall of the pipe. The PE-AL-PE pipes have a hoop stress distribution that differs substantially from both the thick and thin walled pipe cases.

4. Pipe Classification

4.1 *Pipe Diameter*—The PE-AL-PE composite pipes are classified by outside diameter.

4.2 *Pipe Dimension Ratio*—The concept of dimension ratio is not relevant to PE-AL-PE laminated pipes, and cannot be used to relate pressure rating with total wall thickness.

⁴ Available from the Uniform Classification Committee, Suite 1106, 222 South Riverside Plaza, Chicago, IL 60606.

⁵ Available from the National Motor Freight Traffic Association, Inc., National Motor Freight Classification, American Tracking Associations, Inc., Traffic Dept., 1616 P St., NW, Washington, DC 20036.

⁶ Available from Standardization Documents Order Desk, Bldg. 4 Section D, 700 Robbins Ave., Philadelphia, PA 19111-5098, Attn: NPODS.

5. Materials

5.1 *General*—The PE-AL-PE pipe is composed of one metallic layer, two layers of the same polymeric adhesive and two layers of the same polyethylene. For pipe made to this specification the constituent materials must meet the following requirements:

5.2 *Aluminum*—The aluminum shall have a thickness as specified in Table 1. The material shall have minimum elongations and ultimate tensile strengths of 20 % and 100 MPa (14 600 psi), respectively. The tests shall be conducted according to Test Methods E 8.

5.3 *Polyethylene:*

5.3.1 Polyethylene plastics used to make pipe meeting the requirements of this specification are categorized by means of two criteria, namely, (1) short-term strength tests and (2) long-term strength tests.

5.3.2 This specification covers pipe made from PE plastics as defined by three hydrostatic design stresses developed on the basis of long-term tests (see Appendix X1).

5.3.3 Polyethylene plastics used to make pipe meeting the requirements of this specification shall be virgin resin meeting the requirements of either Grade PE20A, B, or C; Grade PE23A, B, or C; Grade PE30A, B, or C; or Grade PE33A, B, or C in accordance with Specification D 3350.

5.3.3.1 Class B compounds shall have sufficient ultraviolet (UV) stabilizers to protect the pipe from deleterious effects due to continuous outdoor exposure during storage and shipping. Pipe produced from Class B compounds is not suitable for exposed outdoor application. Class A, B, and C compounds shall have sufficient antioxidants to meet the requirements in Specification D 3350.

5.3.4 The polyethylene compound used shall meet the minimum 80°C (176°F) temperature stress rupture lifetimes for pipe as specified in Specifications D 2104 and D 3035.

5.4 *Melt Adhesive*—The material shall have a density cell of 1, 2, or 3; a melt index cell of 1, 2, or 3; and a color code of A or B, in accordance with Specification D 3350.

5.5 *Rework Material*—Clean rework material, generated from the manufacturer’s own production, may be used by the same manufacturer, as long as the pipe produced meets all of the requirements of this specification. Rework material containing aluminum or reprocessed or recycled plastics shall not be used for the production of pipe.

TABLE 1 Outside Diameters, Aluminum Thickness, and Tolerances for PE-AL-PE

Nominal Pipe Size, mm (in.)	Minimum Outside Diameter, mm (in.)	Tolerance on Minimum, mm (in.)	Maximum Out-of-Roundness, ^A mm (in.)	Minimum Aluminum Thickness, mm (in.)	Tolerance on Thickness, mm (in.)
0912 (3/8)	12.00 (0.472)	+0.30 (0.012)	0.3 (0.012)	0.18 (0.007)	+0.09 (+0.0035)
1216 (1/2)	16.00 (0.630)	+0.30 (0.012)	0.4 (0.016)	0.18 (0.007)	+0.09 (+0.0035)
1620 (5/8)	20.00 (0.787)	+0.30 (0.012)	0.5 (0.020)	0.23 (0.009)	+0.09 (+0.0035)
2025 (3/4)	25.00 (0.984)	+0.30 (0.012)	0.5 (0.020)	0.23 (0.009)	+0.09 (+0.0035)
2532 (1)	32.00 (1.260)	+0.30 (0.012)	0.5 (0.020)	0.28 (0.011)	+0.09 (+0.0035)
3240 (1 1/4)	40.10 (1.579)	+0.30 (0.012)	0.5 (0.020)	0.33 (0.014)	
4150 (1 1/2)	50.10 (1.972)	+0.30 (0.012)	0.5 (0.020)	0.47 (0.020)	
5163 (2)	63.10 (2.484)	+0.40 (0.016)	0.5 (0.020)	0.57 (0.024)	
6075 (2 1/2)	75.10 (2.957)	+0.60 (0.024)	1.0 (0.039)	0.67 (0.028)	

^AThe out-of-roundness specification applies only to tubing prior to coiling.

6. Requirements

6.1 *General*—The requirements and test methods in this specification cover PE-AL-PE pipes. Tests on the individual layers that comprise this composite pipe are outside the scope of this specification. The raw materials used, however, must conform to the requirements in Section 5.

6.2 Dimensions and Tolerances of Pipe:

6.2.1 *Pipe Diameter*—The minimum outside diameter and tolerances of the pipe shall meet the requirements given in Table 1, when measured in accordance with 9.1 and 9.1.2. Maximum and minimum (out-of-roundness) tolerances apply only to measurements made on pipe prior to coiling.

6.2.2 *Pipe Wall Thickness*—The total pipe wall thickness shall meet the requirements given in Table 2, when measured in accordance with 9.1 and 9.1.3. The minimum wall thickness at any point of measurement of the pipe shall not be less than the minimum wall thickness specified in Table 2.

6.2.3 *Outer Polyethylene Layer Thickness*—The thickness of the outer layer of polyethylene in the PE-AL-PE pipe shall have a minimum value and tolerance as specified in Table 2, except for the polyethylene material overlaying the weld, which shall have a minimum thickness of half that specified in Table 2. The polyethylene thickness is measured in accordance with 9.2.

6.2.4 *Pipe Length*—The pipe shall be supplied coiled or in straight lengths as agreed upon with the purchaser with an allowable tolerance of -0 mm.

6.3 Adhesion Test:

6.3.1 For Sizes 0912 ($\frac{3}{8}$) to 2532 (1) there shall be no delamination of the PE and AL, either on the bore side or the outside (see Fig. 1). The test shall be conducted in accordance with 9.3.1.

6.3.2 The adhesion test of the PE-layer to the aluminum for Sizes 3240 ($1\frac{1}{4}$) to 6075 ($2\frac{1}{2}$) is carried out by a separation test. The minimum adhesive force is specified in Table 3. The adhesive force shall not fall below these levels. The test shall be conducted in accordance with 9.3.2.

6.4 *Apparent Tensile Strength of Pipe*—The pipe rings, when tested in accordance with 9.4, shall meet the minimum strength as specified in Table 4.

6.5 *Minimum Burst Pressure*—The minimum burst pressure for PE-AL-PE pipe shall be as given in Table 4, when determined in accordance with 9.5.

6.6 Sustained Pressure:

6.6.1 The PE-AL-PE pipe rated at 60°C (140°F) shall not fail, balloon, burst, or weep, as defined in Test Method D 1598,

when tested for 10 h at the test pressure given in Table 5 at a temperature of 60°C (140°F) in accordance with 9.6.

6.6.2 PE-AL-PE pipe rated at 82°C (180°F) shall not fail, balloon, burst, or weep as defined in Test Method D 1598 when tested in accordance with 9.6 for 10 h at the test pressure given in Table 5 at a temperature of 82°C (180°F).

7. Workmanship

7.1 The pipe shall be free of visible cracks, holes, foreign inclusions, blisters, and other known injurious defects. The pipe shall be as uniform as commercially practicable in color, opacity, and regularity of the distribution of the polyethylene inside and outside.

8. Sampling and Conditioning

8.1 *Sampling*—Take a sample of the PE-AL-PE pipe sufficient to determine conformance with this specification. The number of specimens designated for each test shall be taken from pipe selected at random in accordance with the random sampling plan of Practice D 1898.

NOTE 1—Sample size and testing frequency of lots for quality control must be established by the manufacturer to ensure conformance to the specification. Sampling and frequency will vary with the specific circumstances.

8.2 *Test Specimens*—Not less than 50 % of the test specimens required for any pressure test shall have at least part of the marking in their central sections. The central section is that portion of the pipe that is at least one pipe diameter away from an end closure.

8.3 *Conditioning*—Condition the specimens at $23 \pm 2^{\circ}\text{C}$ ($73.4 \pm 3.6^{\circ}\text{F}$) and 50 ± 5 % relative humidity for not less than 40 h prior to test in accordance with Procedure A of Practice D 618, for those tests where conditioning is required. In cases of disagreement, the tolerances shall be $\pm 1^{\circ}\text{C}$ ($\pm 1.8^{\circ}\text{F}$) and ± 2 % relative humidity.

8.4 *Test Conditions*—Conduct the test in the standard laboratory atmosphere of $23 \pm 2^{\circ}\text{C}$ ($73.4 \pm 3.6^{\circ}\text{F}$) and 50 ± 5 % relative humidity, unless otherwise specified in the test methods or in this specification. In cases of disagreement, the tolerances shall be $\pm 1^{\circ}\text{C}$ (1.8°F) and ± 2 % relative humidity.

9. Test Methods

9.1 Dimensions and Tolerances:

9.1.1 *Pipe*—Any length of the PE-AL-PE composite pipe may be used to determine dimensions.

TABLE 2 Wall Thickness for PE-AL-PE Composite Pipe

Nominal Pipe Size, mm (in.)	Total Wall Thickness, min, mm (in.)	Wall Tolerance (+) mm	Outer PE Layer Thickness, min, mm (in.)	Inner PE Layer Thickness, min, mm (in.)
0912 ($\frac{3}{8}$)	1.60 (0.063)	0.40 (0.016)	0.40 (0.016)	0.70 (0.028)
1216 ($\frac{1}{2}$)	1.65 (0.065)	0.40 (0.016)	0.40 (0.016)	0.90 (0.035)
1620 ($\frac{5}{8}$)	1.90 (0.075)	0.40 (0.016)	0.40 (0.016)	1.00 (0.039)
2025 ($\frac{3}{4}$)	2.25 (0.089)	0.50 (0.020)	0.40 (0.016)	1.10 (0.043)
2532 (1)	2.90 (0.114)	0.60 (0.024)	0.40 (0.016)	1.20 (0.047)
3240 ($1\frac{1}{4}$)	3.85 (0.152)	0.60 (0.024)	0.40 (0.016)	1.70 (0.067)
4150 ($1\frac{1}{2}$)	4.35 (0.171)	0.60 (0.024)	0.40 (0.016)	1.70 (0.067)
5163 (2)	5.80 (0.228)	0.60 (0.024)	0.40 (0.016)	2.05 (0.081)
6075 ($2\frac{1}{2}$)	7.25 (0.285)	0.60 (0.024)	0.40 (0.016)	2.80 (0.110)

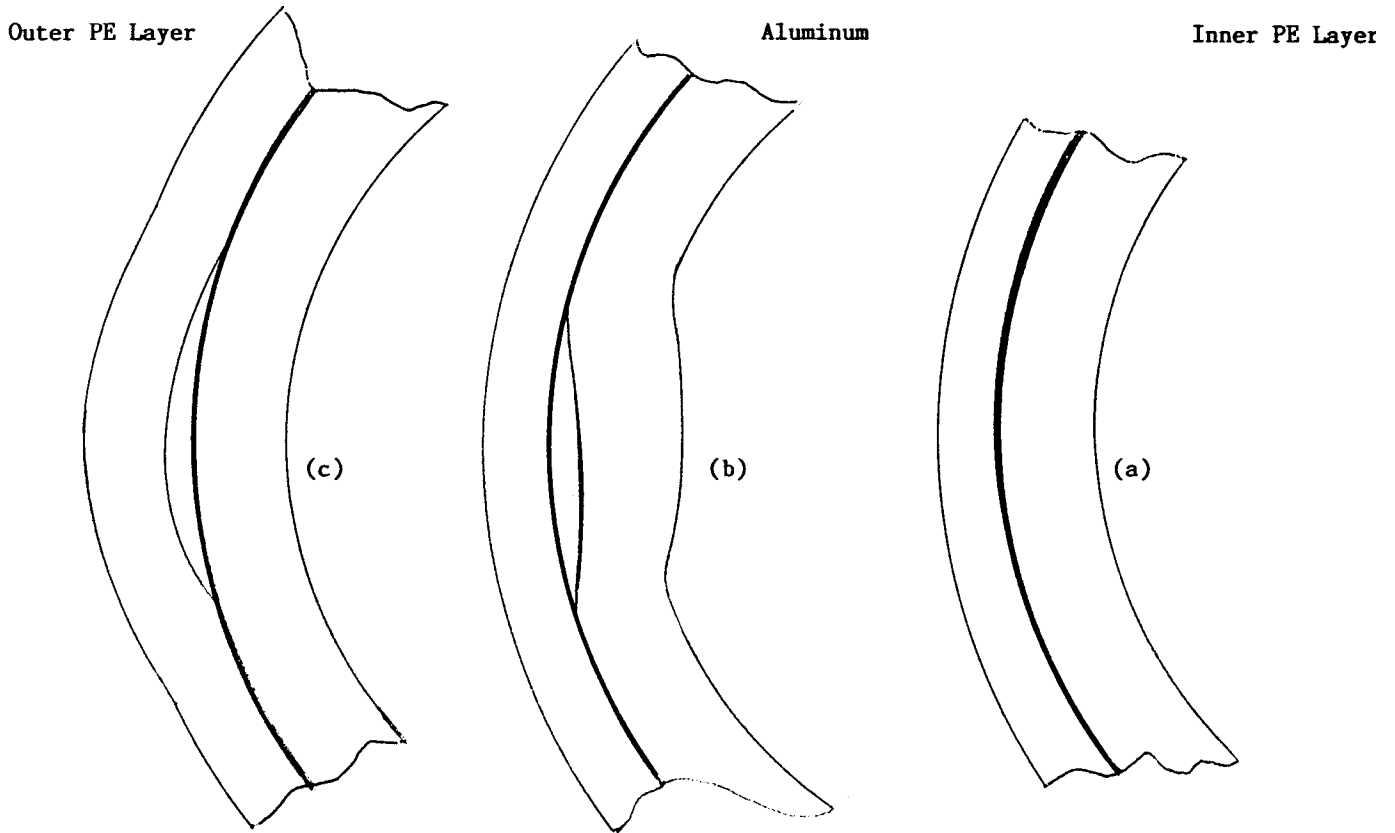

NOTE 1—(a) Good pipe showing no delamination, (b) Delamination between the inner layer and the aluminum, and (c) Delamination between the outer layer and the aluminum.

FIG. 1 Detection of Delamination

TABLE 3 Minimum Adhesive Force for PE-AL-PE Composite Pipe

Nominal Pipe Size, mm (in.)	Minimum Adhesive Force per 10-mm (0.394-in.) Pipe Strip, N (lbf)
3240 (1¼)	40 (9.0)
4150 (1½)	50 (11.2)
5163 (2)	60 (13.5)
6075 (2½)	70 (15.7)

TABLE 4 Minimum Pipe Ring Strengths and 23°C (73.4°F) Burst Pressure of PE-AL-PE Composite Pipe

Nominal Pipe Size, mm (in.)	Minimum Pipe Ring Strength, Type II PE, N (lb)	Minimum Pipe Ring Strength, Type III PE, N (lb)	Minimum 23°C (73.4°F) Burst Pressure, kPa (psi)
0912 (¾)	2000 (448)	2100 (470)	7000 (1020)
1216 (½)	2100 (470)	2300 (515)	6000 (880)
1620 (¾)	2400 (538)	2500 (560)	5000 (730)
2025 (¾)	2400 (538)	2500 (560)	4000 (580)
2532 (1)	2650 (598)	2500 (560)	4000 (580)
3240 (1¼)	3200 (719)	3500 (789)	4000 (580)
4150 (1½)	3500 (789)	3700 (832)	3800 (554)
5163 (2)	5200 (1169)	5500 (1236)	3800 (554)
6075 (2½)	6000 (1349)	6000 (1349)	3800 (554)

9.1.2 *Outside Diameter*—Measure the outside diameter of the PE-AL-PE pipe in accordance with Test Method D 2122.

9.1.3 *Wall Thickness*—Make micrometre measurements of the wall thickness in accordance with Test Method D 2122 to determine the maximum and minimum values. Measure the wall thickness at both ends of the pipe to the nearest 0.01 mm (0.0004 in.).

9.2 *Outer Polyethylene Layer Thickness:*

9.2.1 *Sample Preparation*—Select the sample of pipe at random. Cut the pipe with a sharp knife or other suitable cutter, ensuring that the pipe after cutting is not more than 10 % out-of-round.

9.2.2 *Thickness Determination*—Use a hand held magnifying glass equipped with graduated reticule, or a laboratory microscope with graduated reticule. The reticule should mea-

sure to the nearest 0.1 mm (0.004 in.). Determine the thickness of the outer coating of polyethylene at six points around the circumference. Only one of the points should be at the aluminum weld.

9.3 *Adhesion Test:*

9.3.1 *Visual Test:*

9.3.1.1 *Cutting the Spiral*—Mount a Stanley 1991 or similarly sharp but rigid razor-like blade within a protective housing and angle to cut a 45 ± 5° spiral in the pipe (see Fig. 2). Choose a PEX-AL-PEX pipe at random and insert into the

TABLE 5 Minimum Sustained Pressure for PE-AL-PE Composite Pipe

Nominal Pipe Size, mm (in.)	Minimum Sustained Pressure PE-AL-PE, kPa (psi)	Minimum Sustained Pressure PE-AL-PE, kPa at 82°C (psi at 180°F)
0912 (3/8)	2480 (360)	2340 (340)
1216 (1/2)	2480 (360)	2340 (340)
1620 (5/8)	2480 (360)	2340 (340)
2025 (3/4)	2480 (360)	2340 (340)
2532 (1)	2480 (360)	2340 (340)
3240 (1 1/4)	2100 (305)	...
4150 (1 1/2)	2100 (305)	...
5163 (2)	2100 (305)	...
6075 (2 1/2)	2100 (305)	...

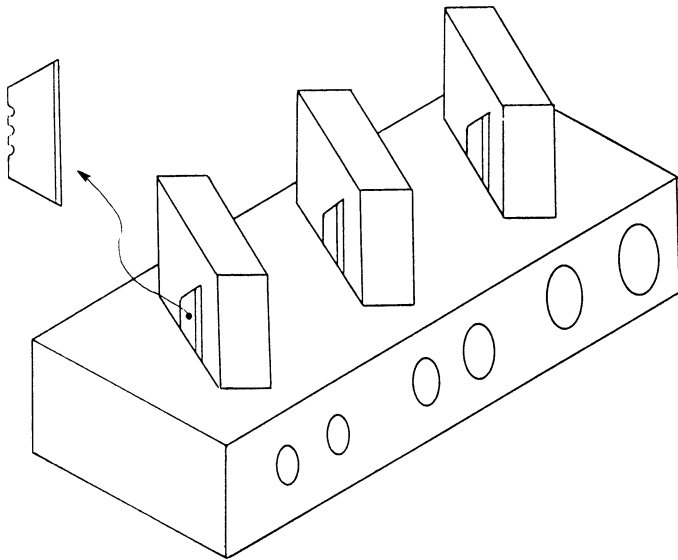

FIG. 2 Spiral Cutter for the Delamination Test

housing and rotate to form the spiral cut. The cut goes through the complete wall on one side of the pipe only. Run the spiral along the pipe for a minimum distance along the pipe axis equal to five times the outside diameter.

9.3.1.2 *Examining for Delamination*—Firmly hold the pipe with the spiral cut at the uncut end and create a ribbon of pipe material by opening out the spiral-cut pipe. Pliers can be used to grip the spiral-cut pipe. Examine the wall of the pipe visually side-on for evidence of delamination between the metal and plastic layers (see Fig. 1).

9.3.2 *Separation Test:*

9.3.2.1 *Specimen*—Five pipe sections of 10-mm (0.394-in.) length are cut at random intervals. The outer layers of the pipe (outer PE-layer together with the aluminum) are separated mechanically from the inner PE-layer with an appropriate device on the opposite side to the welding seam. The outer layers are separated on one side to about 5 mm from the pipe in order to allow clamping. The adhesion for the outer PE-layer to the aluminum is then visually examined for delamination at the corresponding test sample.

9.3.2.2 *Test Equipment:*

(a) (a) *Tension Testing Device*, with suitable pull-off device (see Fig. 3).

(b) (b) D_{roller} = 95 % of the required pipe inner diameter.

(c) (c) d_i = pipe inner diameter.

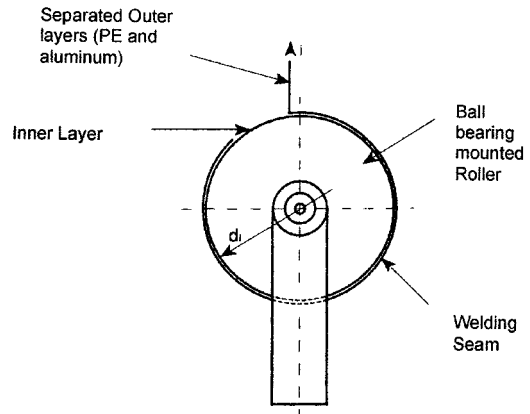

FIG. 3 Setup for Separation Test

9.3.2.3 *Test Procedure*—Remove the outer layers from the pipe at $23 \pm 2^\circ\text{C}$ ($73.4 \pm 3.6^\circ\text{F}$) with a linear speed of 50 mm/min (≈ 2 in./min). Record the force diagram.

9.4 *Ring Test:*

9.4.1 *Sample Size and Shape*—Cut rings of the PE-AL-PE pipe so that the two sides are parallel and at $90 \pm 2^\circ$ to the pipe axis. The length of each ring shall be 25 ± 1 mm (1 ± 0.04 in.). Cut a minimum of 15 samples consecutively along the axis of the pipe.

9.4.2 *Ring Tests*—Test the 15 consecutively cut samples using a tensile testing machine. Arrange the rings so that the aluminum weld is at 90° to the tensile axis as shown in Fig. 4. The crosshead speed shall be 50 ± 2.5 mm/min (2 ± 0.1 in./min). Mount the rings of pipe on two steel rods of minimum diameter of 4 mm (0.16 in.). Record the peak force.

9.5 *Burst Pressure:*

9.5.1 *Pipe Sample*—Select a length of PE-AL-PE pipe at random and prepare five consecutive lengths of 300 ± 5 mm (12 ± 0.2 in.). Seal samples at the ends with the appropriate fittings and test either free- or fixed-end.

9.5.2 *Temperature Control*—Test samples at a temperature of $23 \pm 2^\circ\text{C}$ ($73.4 \pm 3.6^\circ\text{F}$). Contain samples either in a temperature-controlled water bath or in air (at standard laboratory atmosphere). For samples contained in a water bath, 1 h conditioning is required. For samples tested in air, a 16 h conditioning period is required.

9.5.3 *Burst Pressure*—Determine the burst pressure in accordance with the procedure in Test Method D 1599.

9.6 *Sustained Pressure Test:*

9.6.1 *Samples*—Each test sample of PE-AL-PE pipe shall have a minimum length between end closures of at least ten

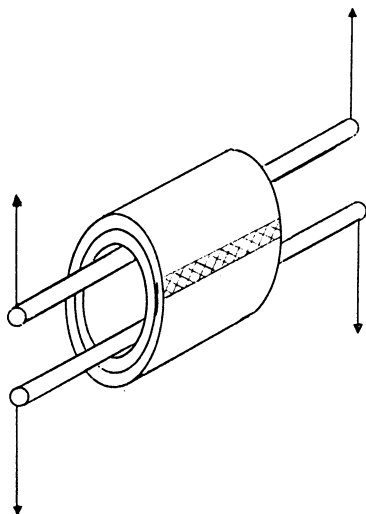

FIG. 4 Schematic Presentation of the Pipe Ring Test Showing the Aluminum Weld at 90° to the Tensile Axis

times the average outside diameter, but not less than 250 mm (10 in.). Seal specimens at both ends with the appropriate fittings and fill the samples for testing with potable drinking water.

9.6.2 *Test Procedures*—Test each sample individually in a temperature controlled water bath or in air in accordance with Test Method D 1598. Test at $60 \pm 2^\circ\text{C}$ ($140 \pm 3.6^\circ\text{F}$) or $82 \pm 2^\circ\text{C}$ ($180 \pm 3.6^\circ\text{F}$) in accordance with 6.6. For each pipe size test six samples. For testing in a water bath, condition the test samples for at least 2 h in the water bath at the test temperature prior to pressurization. For testing in air, condition the samples for at least 4 h in air at the test temperature prior to pressurization. Maintain the pressure at the pressure given in Table 5 for the duration of the test.

9.6.3 *Failure*—Any continuous loss of pressure of the test sample shall constitute failure of the test. Failure of one of the

six is cause for retest of six additional samples under identical conditions. Failure of one of six of the retested samples below the minimum specified lifetime constitutes failure of the test.

10. Quality Assurance

10.1 When the product is marked with this designation, ASTM F 1282, the manufacturer affirms that the product was manufactured, inspected, sampled, and tested in accordance with this specification and has been found to meet the requirements of this specification. When specified in the purchase order or contract, a report of the test results shall be furnished.

11. Marking

11.1 *Quality of Marking*—The marking shall be applied to the pipe in such a manner that it remains legible (easily read) after installation and inspection.

11.2 Markings on the tubing shall include the following, spaced at intervals of not more than 1.5 m (5 ft):

11.2.1 Nominal tubing size (for example, 1216),

11.2.2 The material designation “PE-AL-PE,”

11.2.3 Pressure rating for water and temperature for which the pressure rating is valid,

11.2.4 ASTM designation F 1282, with which the tubing complies, and

11.2.5 Manufacturer’s name (or trademark) and production code.

11.2.6 Tubing intended for the transport of potable water shall also include the seal or mark of the laboratory making the evaluation and the number of the standard used for the evaluation.

NOTE 2—Manufacturers using the seal or mark of a laboratory must obtain prior authorization from the laboratory concerned.

12. Keywords

12.1 composite; PE-AL-PE; pipe; polyethylene; pressure

SUPPLEMENTARY REQUIREMENTS

GOVERNMENT/MILITARY PROCUREMENT

These requirements apply *only* to Federal/Military procurement, not domestic sales or transfers.

S1. *Responsibility for Inspection*—Unless otherwise specified in the contract or purchase order, the producer is responsible for the performance of all inspection and test requirements specified herein. The producer may use his own or any other suitable facilities for the performance of the inspection and test requirements specified herein, unless disapproved by the purchaser. The purchaser shall have the right to perform any of the inspections and tests set forth in this specification where such inspections are deemed necessary to ensure that material conforms to prescribed requirements.

NOTE S1.1—In U. S. Federal Government contracts, the contractor is responsible for inspection.

S2. *Packaging and Marking for U.S. Government Procurement*:

S2.1 *Packaging*—Unless otherwise specified in the contract, the material shall be packaged in accordance with the supplier’s standard practice in a manner ensuring arrival at destination in a satisfactory condition and which will be acceptable to the carrier at lowest rates. Containers and packaging shall comply with Uniform Freight Classification rules or National Motors Freight Classification rules.

S2.2 *Marking*—Marking for shipment shall be in accordance with Fed. Std. No. 123 for civil agencies and MIL-STD-129 for military agencies.

NOTE S2.1—The inclusion of U. S. Federal Government procurement requirements should not be construed as an indication that the U. S. Government uses or endorses the products described in this specification.

POTABLE WATER REQUIREMENT

This requirement applies whenever a Regulatory Authority or user calls for product to be used to convey or be in contact with potable water.

S3. Products intended for contact with potable water shall be evaluated, tested and certified for conformance with ANSI/NSF Standard No. 61 or the health effects portion of NSF

Standard No. 14 by an acceptable certifying organization when required by the regulatory authority having jurisdiction.

ANNEXES

(Mandatory Information)

A1. CONNECTORS

A1.1 Connectors shall be made from brass or any other material found to be suitable for the service conditions.

A1.2 The connectors shall be designed so that a seal is effected on the internal wall surface of the pipe so that the medium contained in the pipe is precluded from coming into

contact with the cut end of the pipe.

A1.3 Connectors not made from brass shall be capable of meeting the short term pipe test requirements listed in 6.5 and 6.6 of this specification and the long term hydrostatic capabilities of the pipe at elevated temperatures listed in Appendix X1.

A2. PERFORMANCE REQUIREMENTS OF CONNECTORS

A2.1 *General*—All performance testing of connectors shall be performed on assemblies of connectors and PE/AL/PE pipe meeting the requirements of this Specification. Assembly of test specimens shall be in accordance with Appendix X4. Use separate sets of assemblies for each performance test requirement.

NOTE A2.1—Fittings manufactured in compliance with Specification F 1974 meet all of the performance requirements provided in this Annex.

A2.2 *Hydrostatic Burst*—Assemblies shall meet the minimum hydrostatic burst requirements shown in Table A2.1 when tested in accordance with 9.5, except that the test temperature shall be 140 °F (60 °C).

A2.3 *Hydrostatic Sustained Pressure Strength*—Pipe and

connector assemblies shall not separate or leak when tested in accordance with A2.5.2.

A2.4 *Thermocycling*—Assemblies shall not leak or separate when thermocycled 1000 cycles between the temperatures of 60 °F (15.6 °C) and 140 °F (60 °C) in accordance with A2.5.3.

A2.5 Test Methods:

A2.5.1 Sampling and Conditioning shall be done in accordance with Section 8.

A2.5.2 Hydrostatic Sustained Pressure:

A2.5.2.1 Perform the test on at least six assemblies in accordance with Test Method D 1598, except for the following:

- (1) The test temperature shall be at 140 ± 4 °F (60 ± 2 °C),
- (2) The test pressure shall be 320 psi (2 205 kPa),
- (3) The external test environment shall be air or water, and
- (4) The specimens shall be filled with water at a temperature of at least 120 °F (49 °C).

A2.5.2.2 Leakage or separation at any joint tested at less than 1000 h at the sustained pressure shall constitute failure in this test.

A2.5.3 Thermocycling:

A2.5.3.1 *Summary of Test Method*—This test method describes a pass-fail test for thermally cycling assemblies comprised of insert connector and pipe over a critical temperature range for a selected number of cycles while subjected to an internal pressure. The test provides a measure of resistance to

TABLE A2.1 Minimum Hydrostatic Burst Strength Requirements for Connector and PE/AL/PE Pipe Assemblies

Nominal Pipe Size, mm (in.)		Minimum Burst Pressures	
		psi at 140°F	kPa at 60°C
1216	(1/2)	580	(4000)
1620	(5/8)	550	(3800)
2025	(3/4)	465	(3200)
2532	(1)	465	(3200)
3240	(1 1/4)	362	(2500)
4150	(1 1/2)	333	(2300)
5163	(2)	295	(2000)
6075	(2 1/2)	295	(2000)

failure due to the combined effects of differential thermal expansion and creep of connections intended for use up to and including 140 °F (60 °C).

A2.5.3.2 Apparatus—A compressed air or nitrogen pressure source capable of maintaining an internal pressure of 100 ± 10 psi (690 ± 69 kPa) on the specimens is required. A dip test apparatus capable of automatically immersing test samples at prescribed intervals in temperature-controlled water baths capable of providing continuous water temperatures of 60 ± 4 °F (15.6 ± 2 °C) and 140 ± 4 °F (60 ± 2 °C) is required.

A2.5.3.3 Specimen Preparation—Six assemblies of the type of connector to be tested shall be prepared. The connectors with suitable lengths of pipe meeting the requirements of the applicable Standard shall be assembled and attached to a common manifold. Assemble strictly according to the instructions of the connector manufacturer. Close the specimen assembly with any suitable end closures that allow “free end” mounting and will not leak under the thermocycling conditions, and connect the specimen assembly to the pressure source.

A2.5.3.4 Procedure—Pressurize the specimen assembly with nitrogen or air to 100 ± 10 psi (690 ± 69 kPa), immerse in 60 ± 4 °F (15.6 ± 2 °C) water, and check for leaks. Eliminate all leaks before the thermocycling test is started. With the specimen assembly pressurized to 100 ± 10 psi (690 ± 69 kPa), thermally cycle it between 60 ± 4 °F (15.6 ± 2 °C) and 140 ± 4 °F (60 ± 2 °C) by means of immersion in water using the following test cycle (Note A2.2):

Water immersion at 140 °F (60 °C)	2 min minimum
Air immersion at ambient	2 min maximum
Water immersion at 60 °F (15.6 °C)	2 min minimum
Air immersion at ambient	2 min maximum

NOTE A2.2—If the test must be interrupted before completion, samples are to be kept at room temperature until the test is restarted.

(1) Upon completion of 1000 cycles, immerse the specimen assembly again in 60 °F (15.6 ± 2 °C) water, and check

for leaks. Any evidence of leakage at the connectors or separation of the connectors from the pipe constitute failure.

(2) If no failures are evident, the specimen assembly shall immediately be tested for joint integrity (hydrostatic burst) at 73 °F (23 °C) in accordance with Test Method D 1599. Leakage or separation during the hydrostatic burst test of any of the joints in the assembly at less than the pressure shown in Table A2.1 shall constitute failure of this test.

A2.5.3.5 Interpretation of Results—Failure of any one of six specimens in the assembly shall constitute failure of this test.

A2.6 Product Marking of Connectors:

A2.6.1 Quality Assurance—When the connector or connector packing is marked with the ASTM designation F 1282, the manufacturer affirms that the product was manufactured, inspected, sampled, and tested in accordance with this specification and has been found to meet the requirements of this specification.

A2.6.2 Quality of Marking—The marking shall be applied to the connectors in such a manner that it remains legible after installation and inspection.

A2.6.3 Content of Marking:

A2.6.3.1 Marking on connectors shall include:

(1) Manufacturer’s name or trademark, or some other identifying mark, and

(2) F 1282, the standard designation. Fittings that also comply with the requirements of F 1281 shall be marked F 1281/2 instead of F 1282.

A2.6.3.2 Marking on packaging shall include:

(1) Manufacturer’s name,

(2) Connector size, and

(3) “ASTM F 1282.”

A2.6.3.3 Marking on crimp rings shall include the code letters, PAP.

APPENDIXES

(Nonmandatory Information)

X1. SOURCE OF HYDROSTATIC DESIGN STRESSES

X1.1 The hydrostatic design stresses recommended by the Plastics Pipe Institute are used to pressure rate PE plastic pipe materials. These hydrostatic design stresses are 2.76 MPa (400 psi), 3.45 MPa (500 psi), 4.34 MPa (630 psi), and 5.25 MPa (800 psi) for water at 23°C (73°F).

X1.2 Seven PE pipe materials are included, based on the requirements of Specification D 1248 and the PPI-recommended hydrostatic design stresses, as follows:

X1.2.1 Grade P23 with a hydrostatic design stress of 4.34 MPa (630 psi) for water at 23°C (73°F), designated PE2306.

X1.2.2 Grade P24 with a hydrostatic design stress of 4.34 MPa (630 psi) for water at 23°C (73°F), designated PE2406.

X1.2.3 Grade P33 with a hydrostatic design stress of 4.34 MPa (630 psi) for water at 23°C (73°F), designated PE3306.

X1.2.4 Grade P34 with a hydrostatic design stress of 4.34 MPa (630 psi) for water at 23°C (73°F), designated PE3406.

X1.2.5 Grade P34 with a hydrostatic design stress of 5.25 MPa (800 psi) for water at 23°C (73°F), designated PE3408.

X1.3 Information regarding criteria used in developing these hydrostatic design stresses may be obtained from the Plastics Pipe Institute, 355 Lexington Avenue, New York, NY 10017 (see Note X1.1). These hydrostatic stresses may not be suitable for materials that show a wide departure from a straight line plot of log stress versus log time to failure. All the data available to date on PE pipe materials made in the United States exhibit a straight-line plot under these plotting conditions.

NOTE X1.1—Refer also to Test Method D 2837.

X2. PRESSURE RATING

X2.1 The hydrostatic design basis-pressures for water recommended by the Plastic Pipe Institute are used to pressure rate the PE-AL-PE composite pipe covered by this specification. These design basis-pressures are 2.76 MPa (400 psi) at 23°C (73.4°F) and 2.21 MPa (320 psi) at 60°C (140°F). These hydrostatic design basis-pressures apply only to pipe meeting all of the requirements of this specification.

X2.2 The PE-AL-PE composite pipe meeting the requirements of this specification shall be pressure rated for maximum water pressures of 1.38 MPa (200 psi) at 23°C (73.4°F) and 1.10 MPa (160 psi) at 60°C (140°F) or 0.69 MPa (100 psig) at 82°C (180°F). See PPI TR-4 for these listings.

X3. STORAGE

X3.1 *Outside Storage*—Pipe should be stored on a flat surface and supported in a manner that will prevent distortion.

X4. JOINING

X4.1 Cut the pipe square to the proper length.

X4.2 Select the proper size tool (if required) for pipe preparation/joining. Only use tools specific to the design of the connector system.

X4.3 Assemble and complete the joint in accordance with the manufacturer's instructions specific to the type of connectors being used.

ASTM International takes no position respecting the validity of any patent rights asserted in connection with any item mentioned in this standard. Users of this standard are expressly advised that determination of the validity of any such patent rights, and the risk of infringement of such rights, are entirely their own responsibility.

This standard is subject to revision at any time by the responsible technical committee and must be reviewed every five years and if not revised, either reapproved or withdrawn. Your comments are invited either for revision of this standard or for additional standards and should be addressed to ASTM International Headquarters. Your comments will receive careful consideration at a meeting of the responsible technical committee, which you may attend. If you feel that your comments have not received a fair hearing you should make your views known to the ASTM Committee on Standards, at the address shown below.

This standard is copyrighted by ASTM International, 100 Barr Harbor Drive, PO Box C700, West Conshohocken, PA 19428-2959, United States. Individual reprints (single or multiple copies) of this standard may be obtained by contacting ASTM at the above address or at 610-832-9585 (phone), 610-832-9555 (fax), or service@astm.org (e-mail); or through the ASTM website (www.astm.org).